

NURIA

1
2

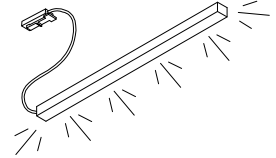

2
10

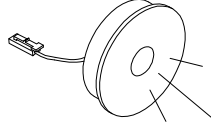
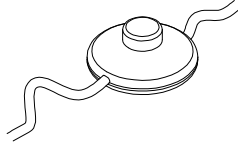
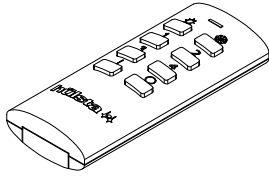
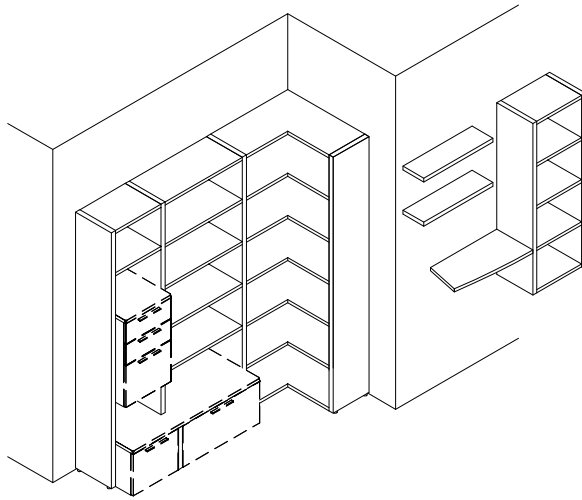

3
28

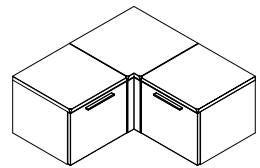
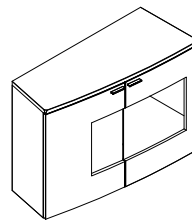
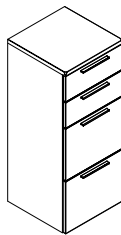
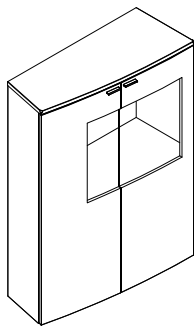
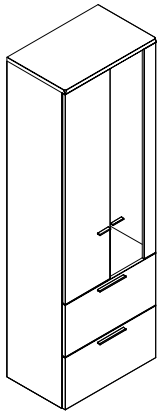

hülsta 

EAC

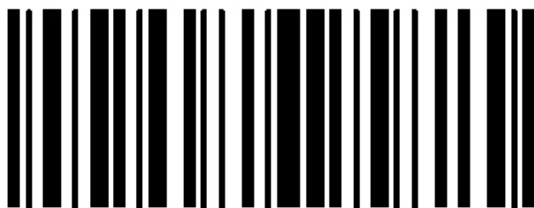

1646044

hülsta-werke · Karl-Hüls-Straße 1 · 48703 Stadtlohn
TEL +49 2563 86-0 · FAX +49 2563 86-1417
www.huelsta.com · 09 / 2019

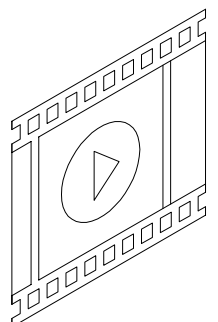
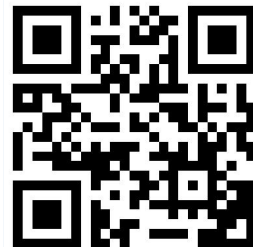

NURIA

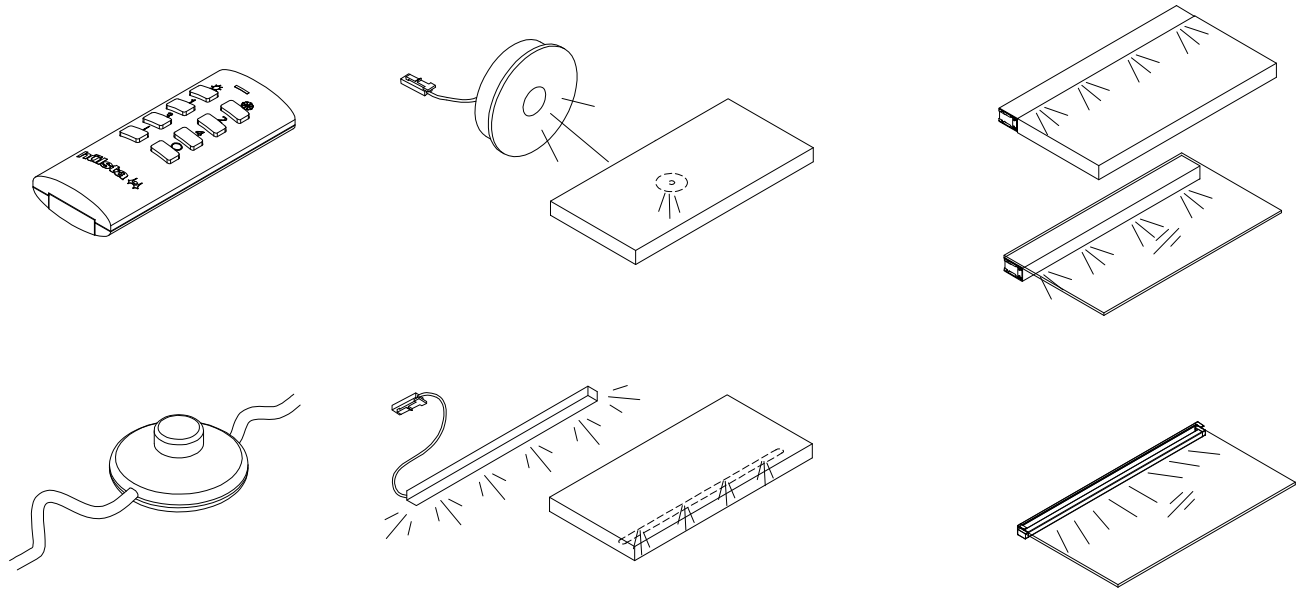

hülsta 

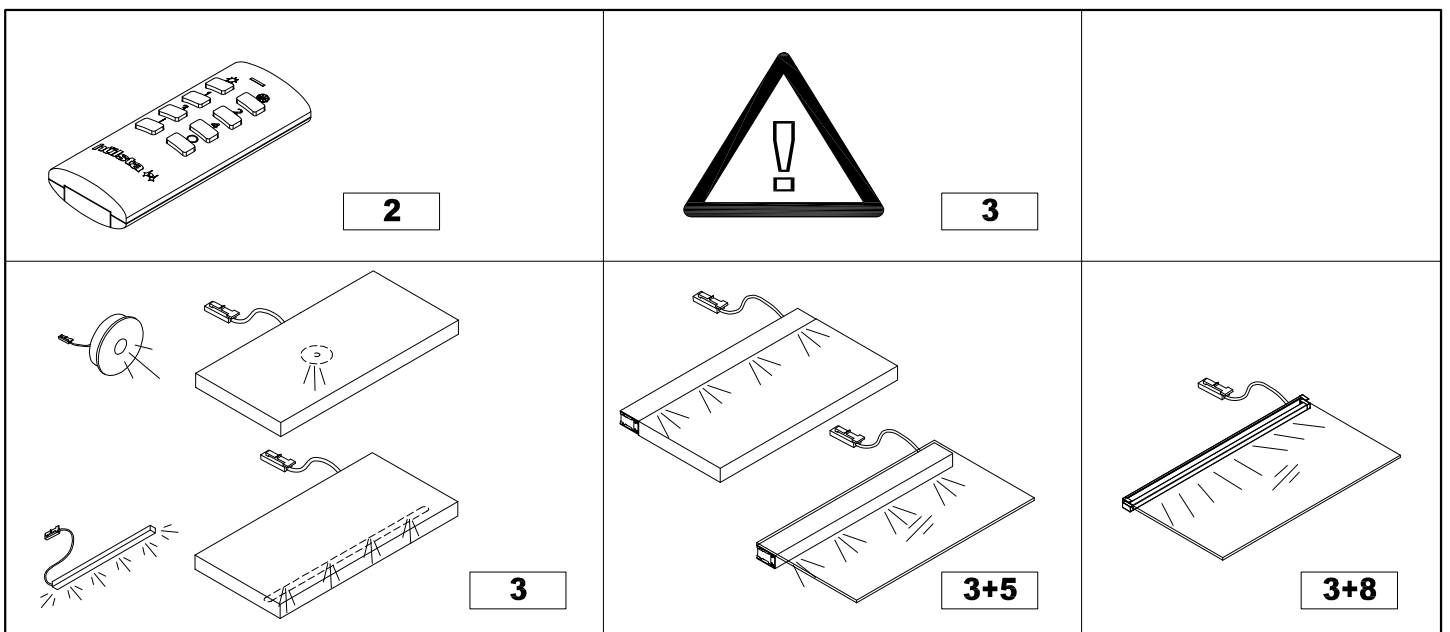
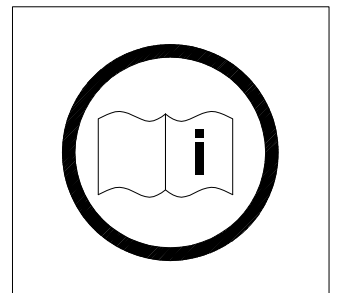
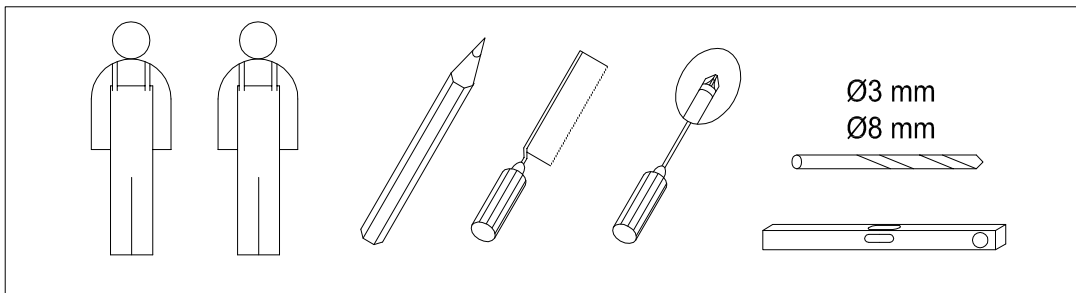

1

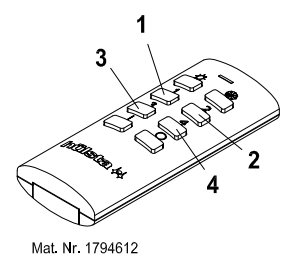
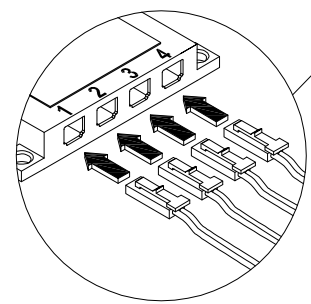
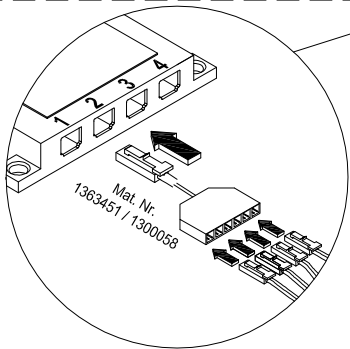
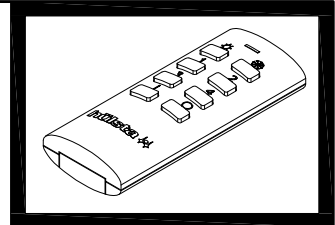
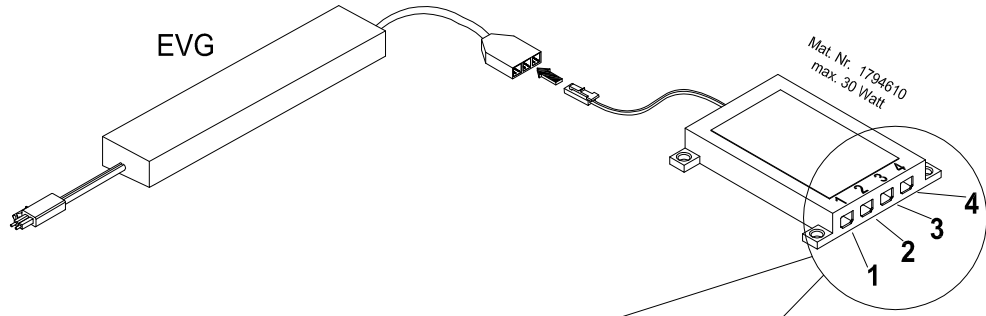

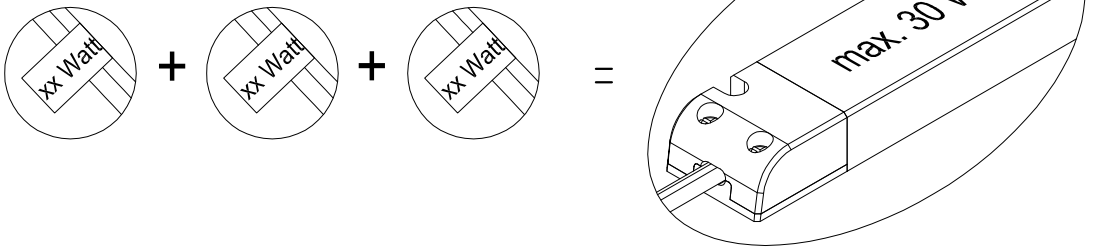
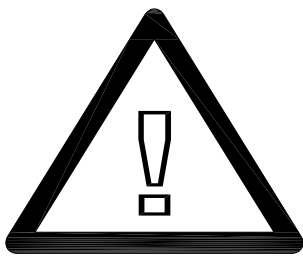
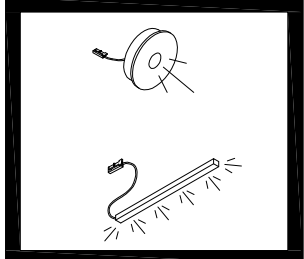
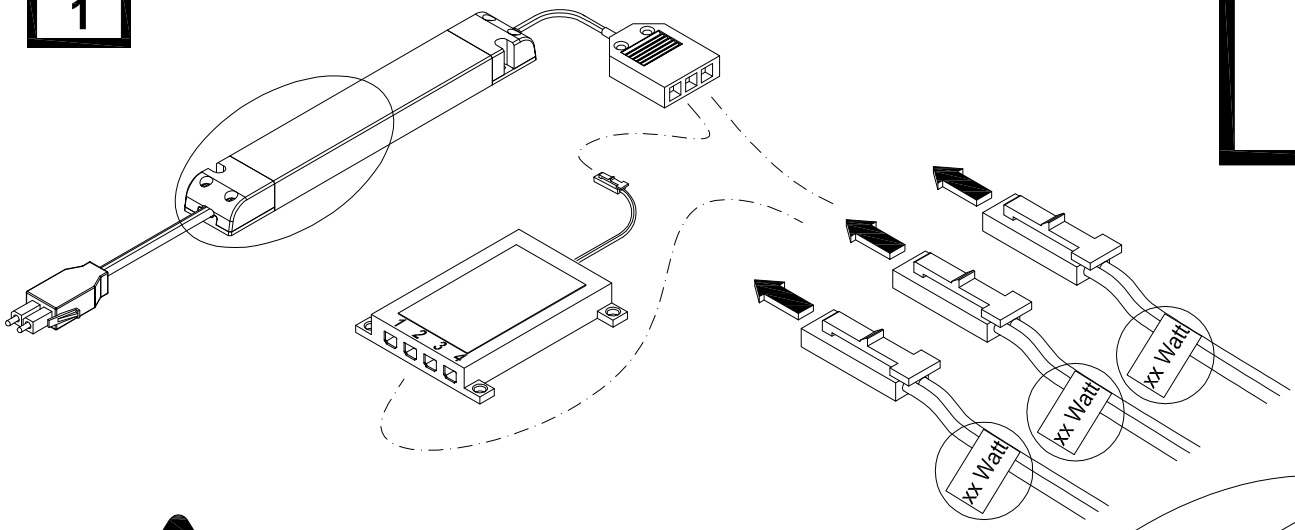

1

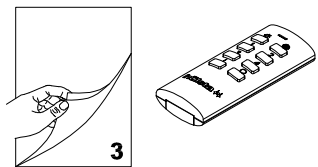
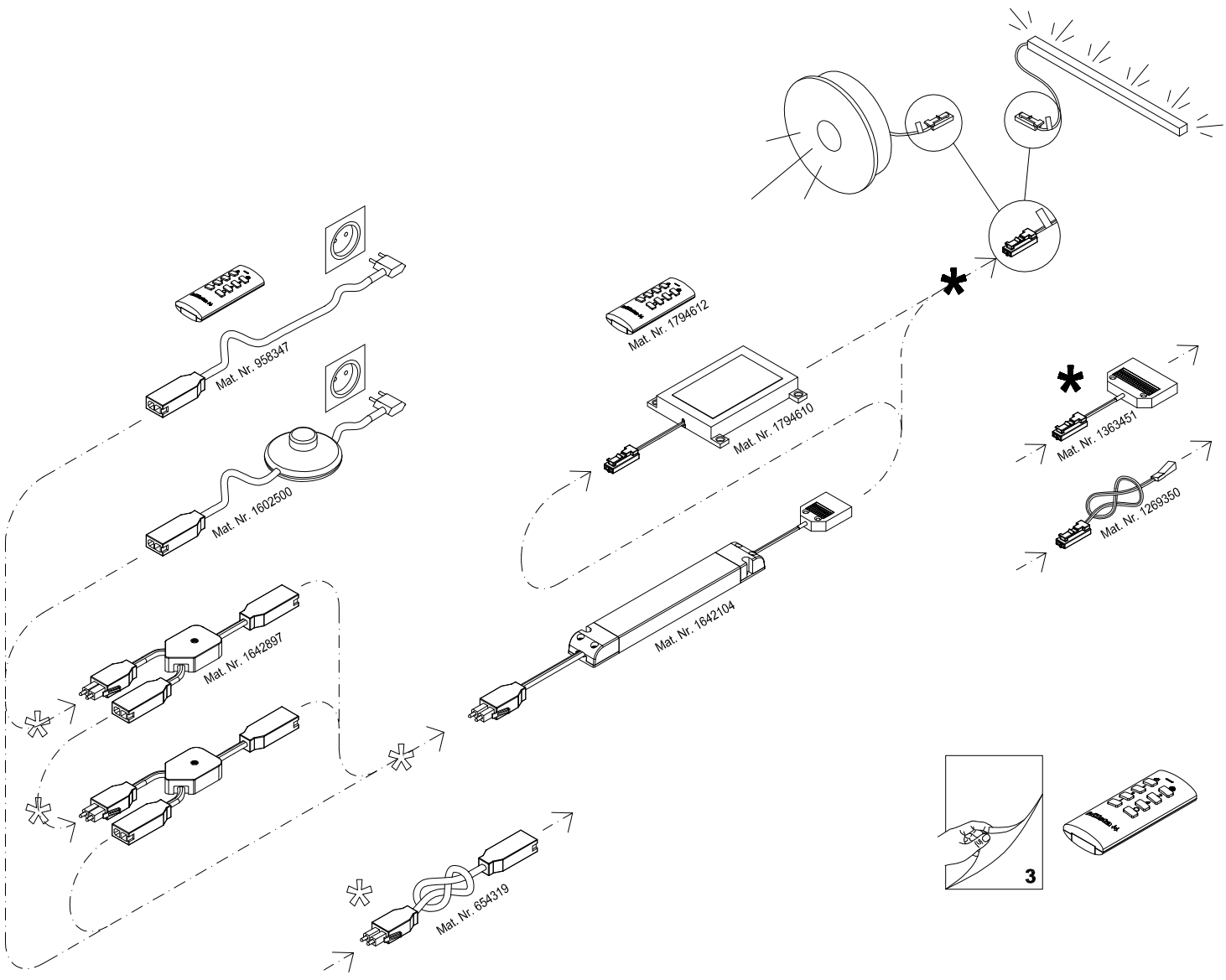
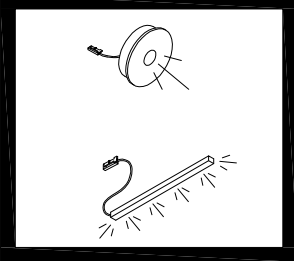





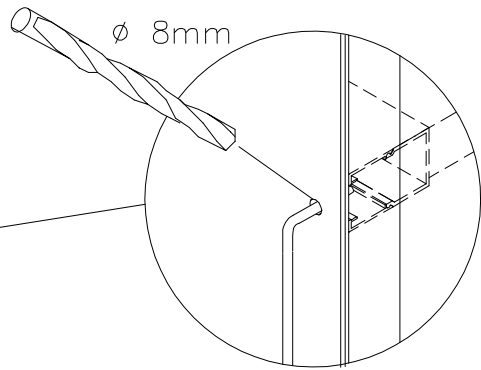
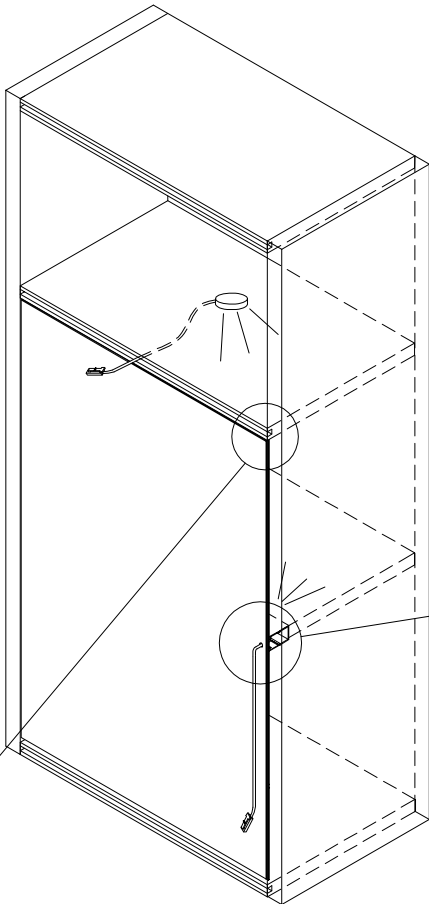

3

Mat. 1621435		
10x		32x10x0,2
BB 608		Mat. 228716
10x		

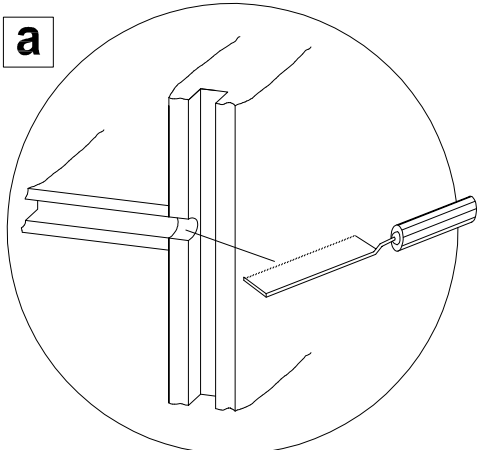
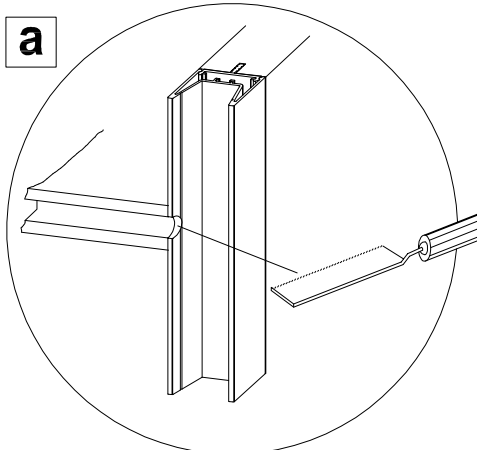
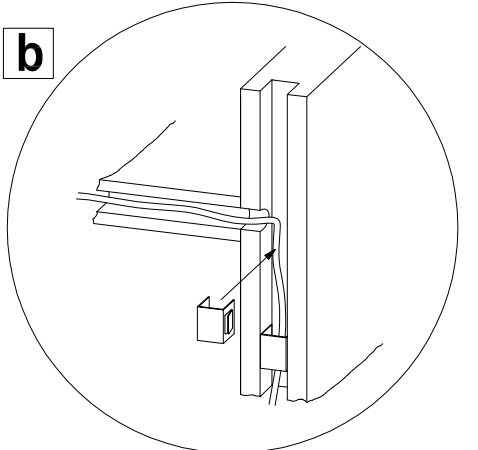
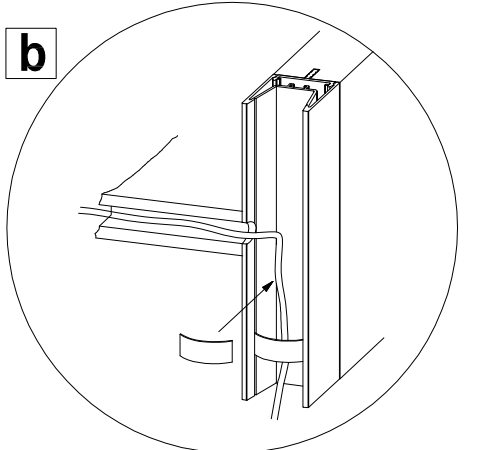

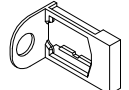
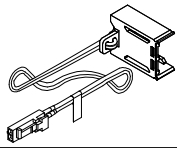

 <p>BB 608</p>	 <p>1621435</p>
<p>a</p> 	<p>a</p> 
<p>b</p> 	<p>b</p> 

RECHTS

1x		
2x		3x13
1x		
1x		

LINKS

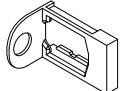
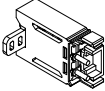
1x		
2x		3x13
1x		
1x		

(1)

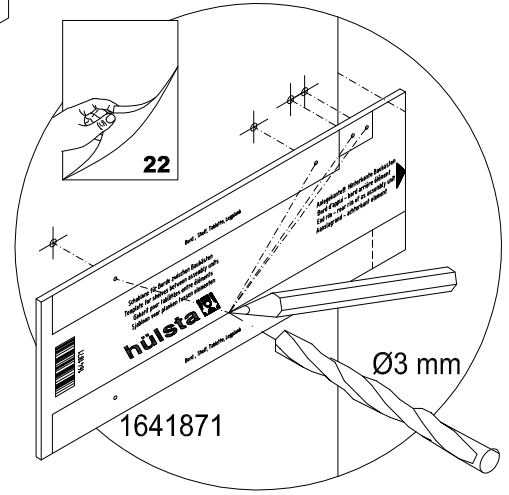
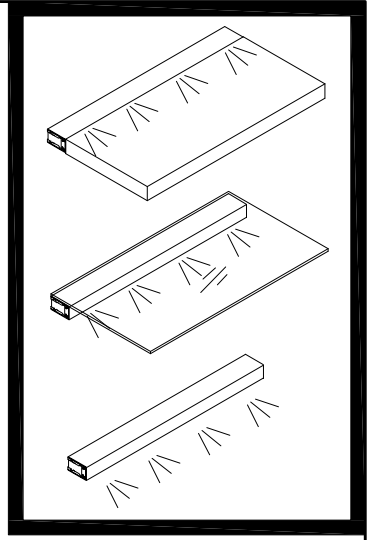
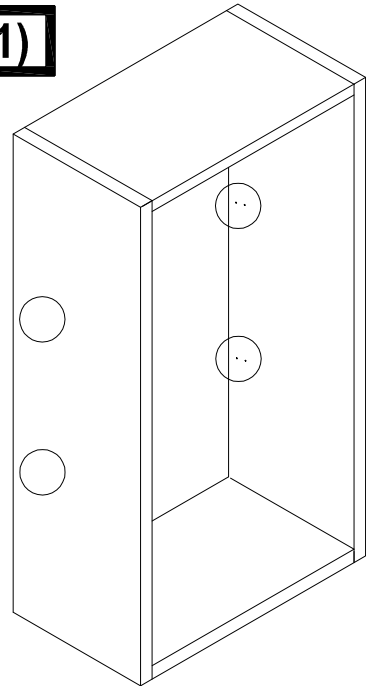

2

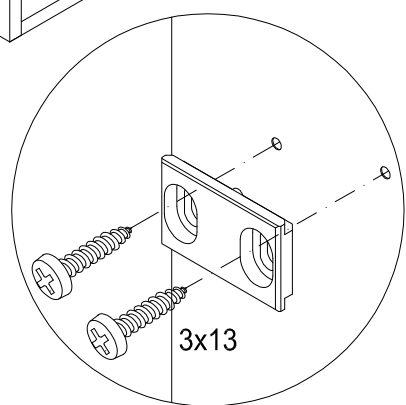
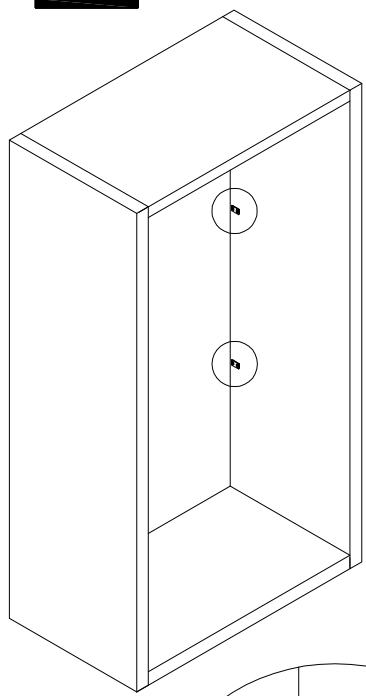

3

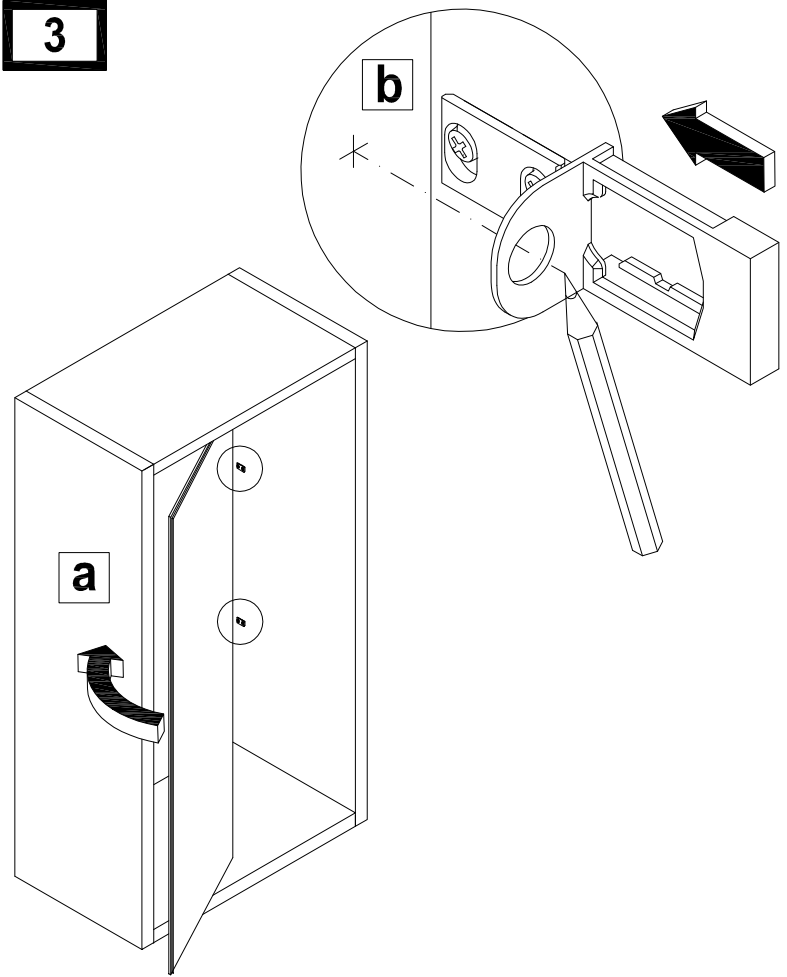

4

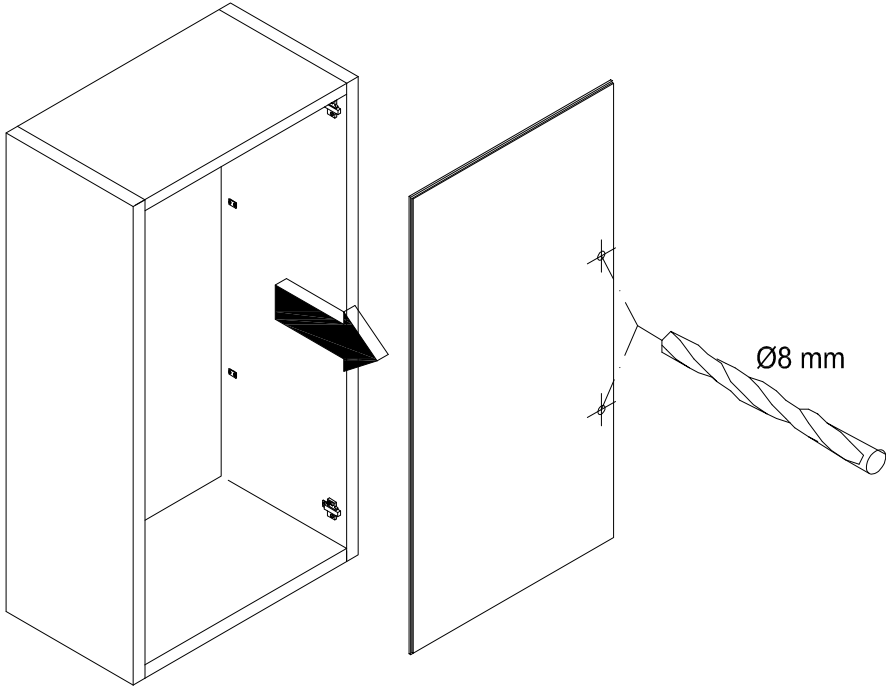

5

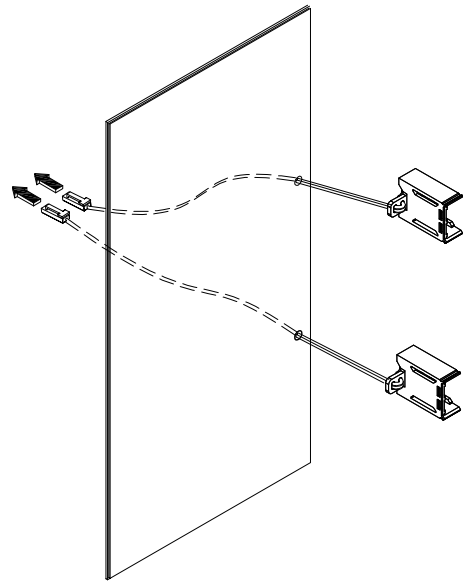

6

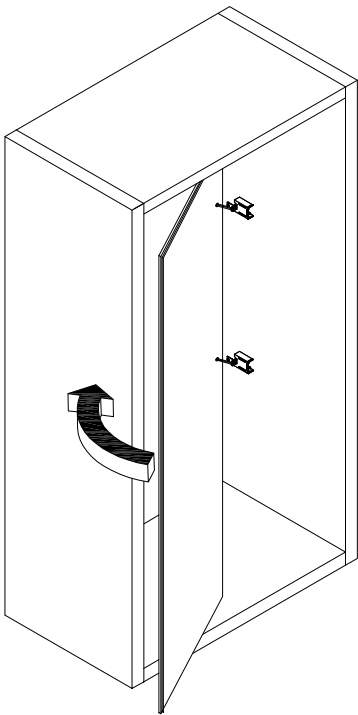

7

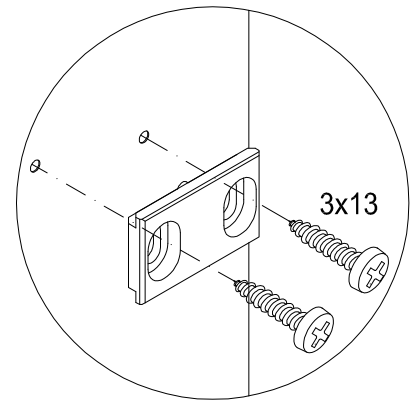
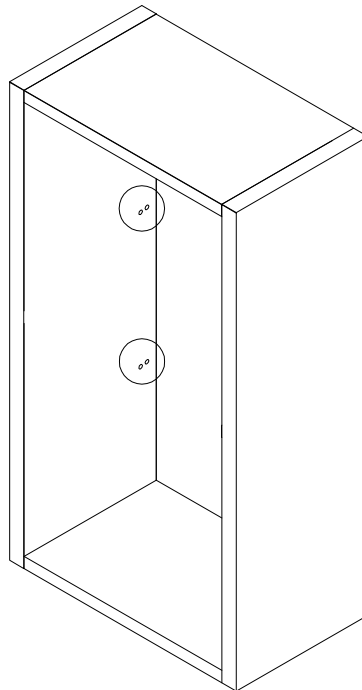

8

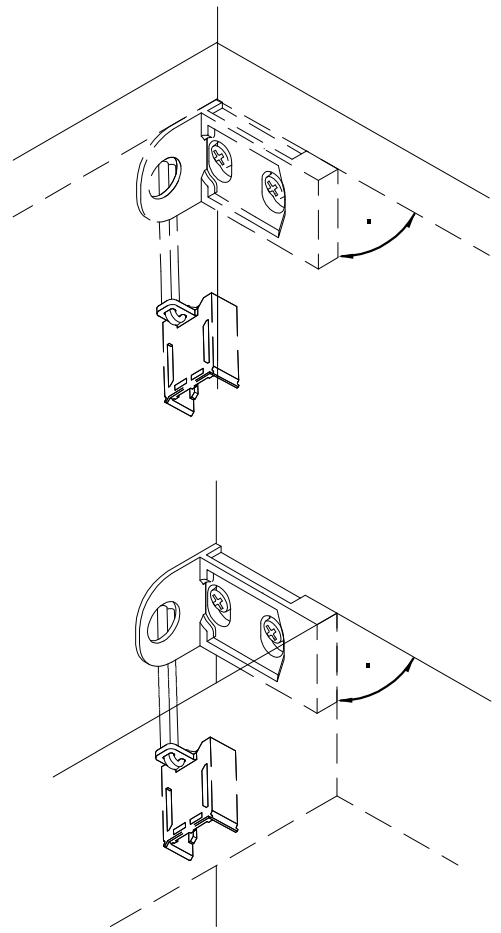
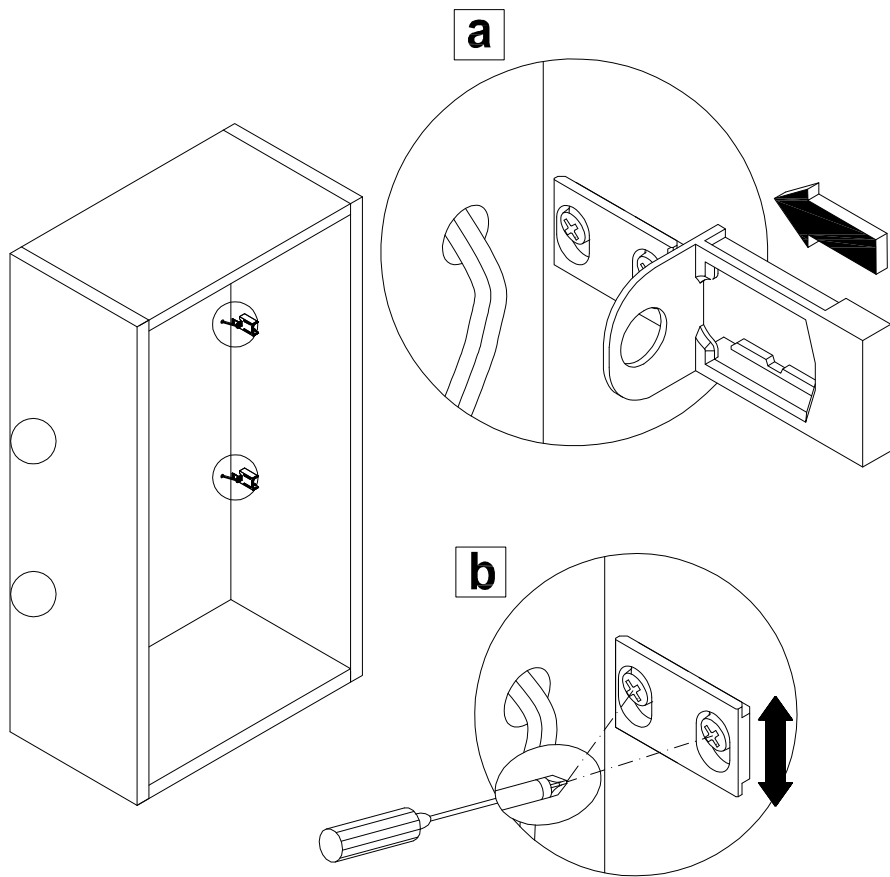

9

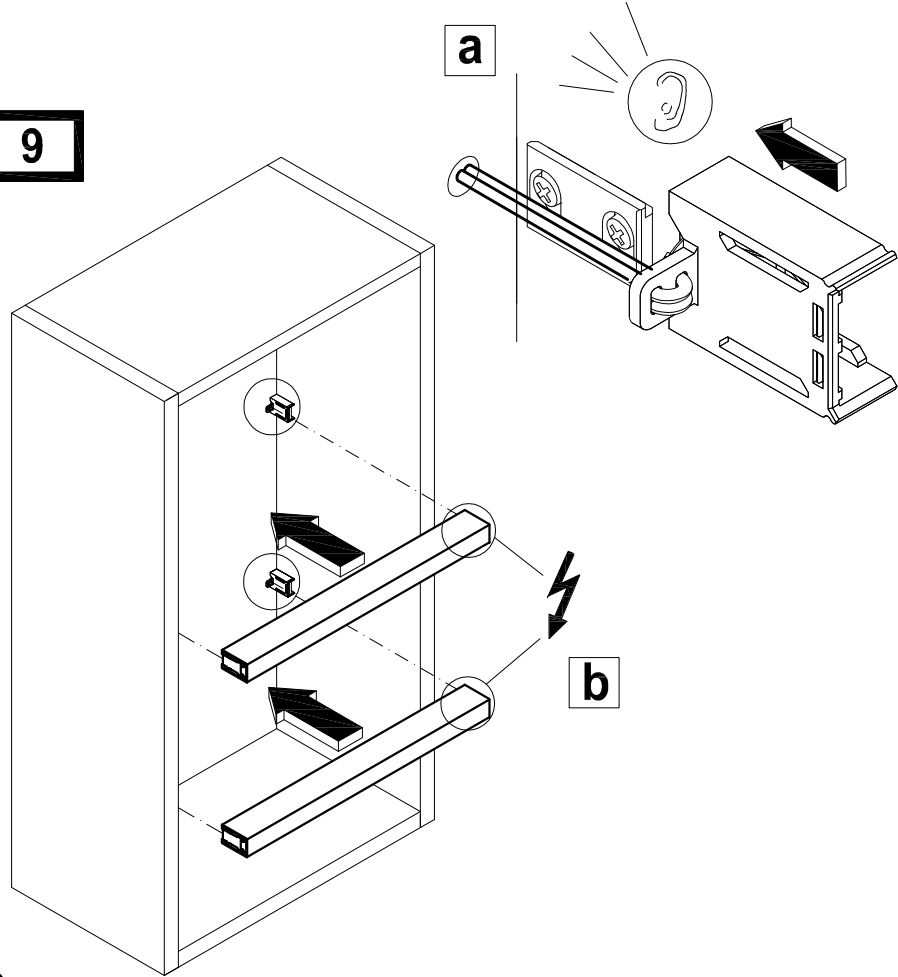

10

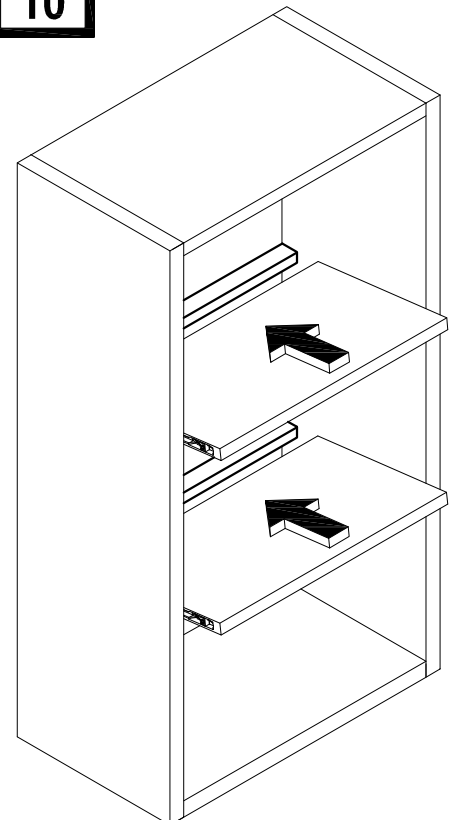

1

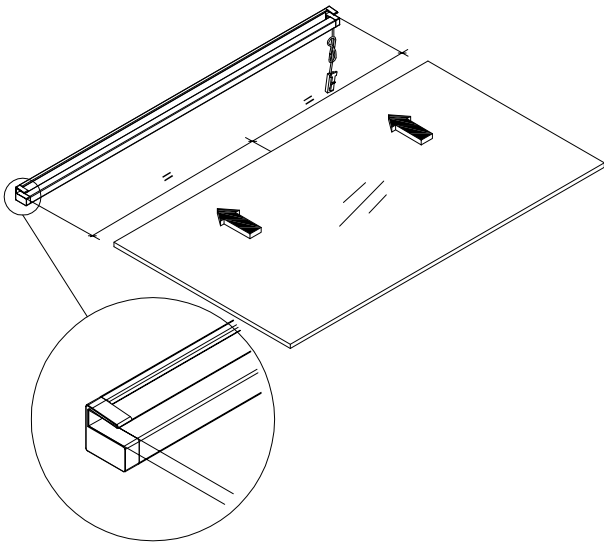

2

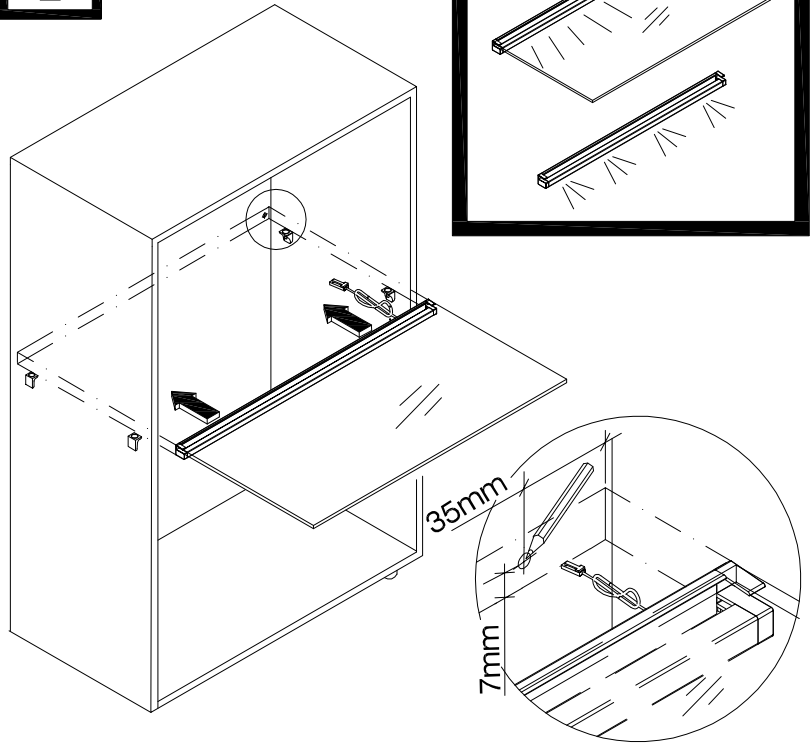

3

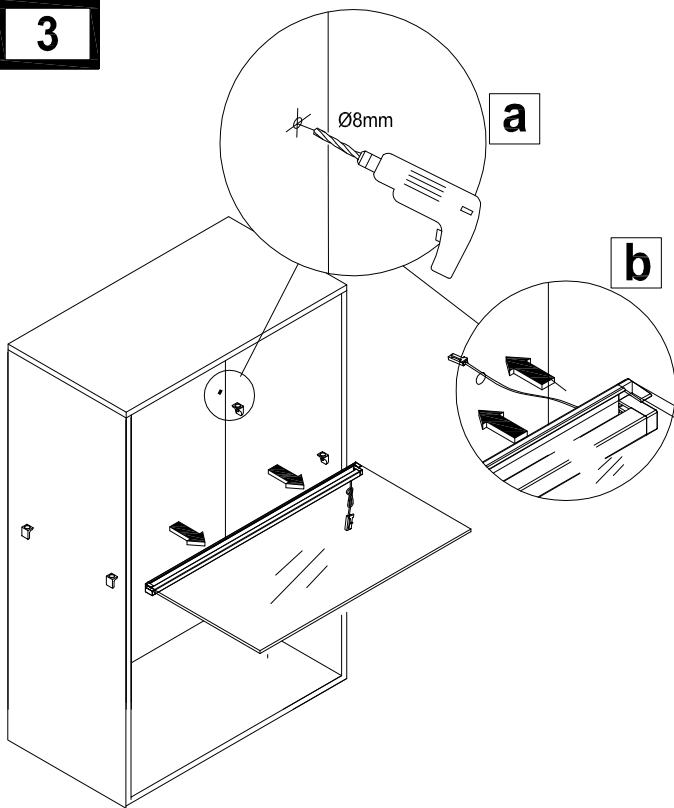



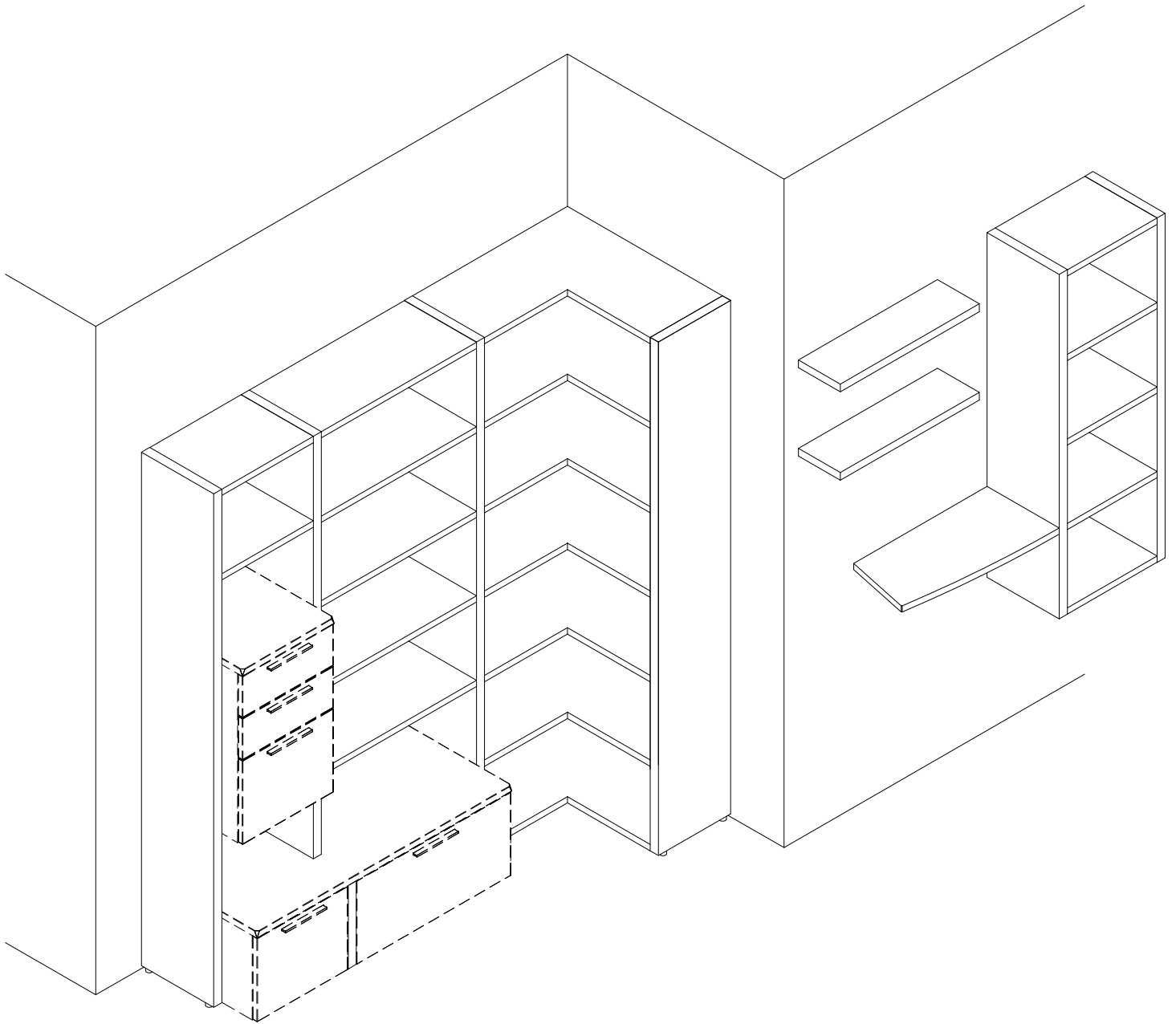

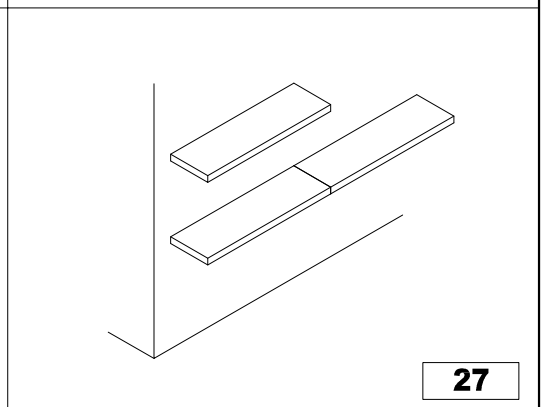
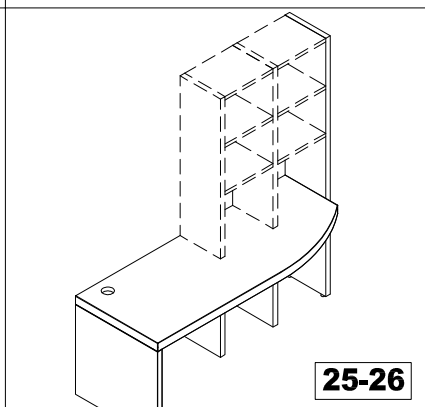
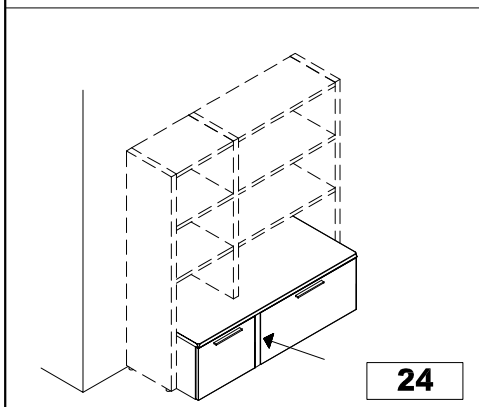
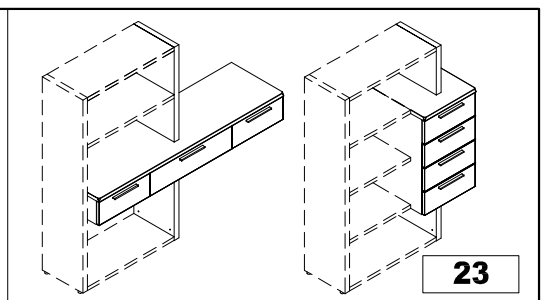
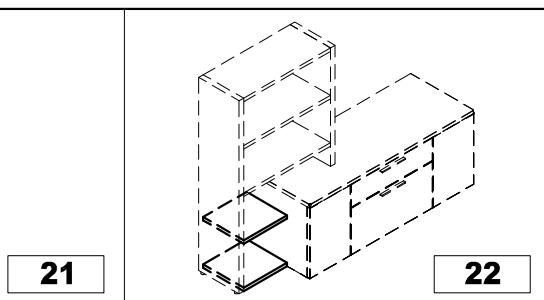
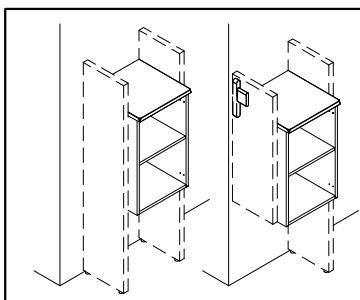
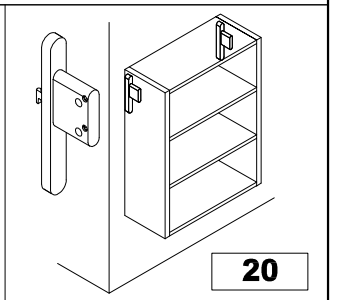
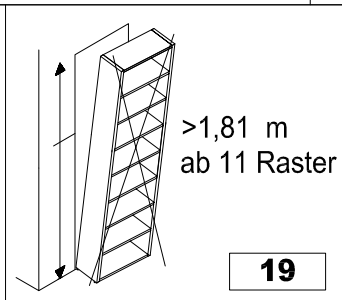
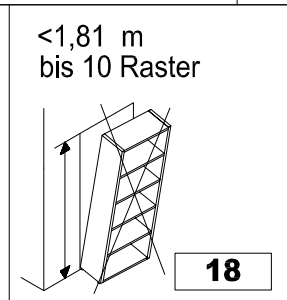
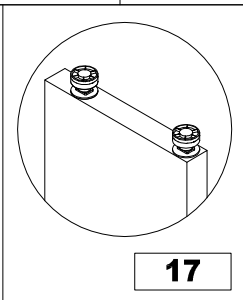
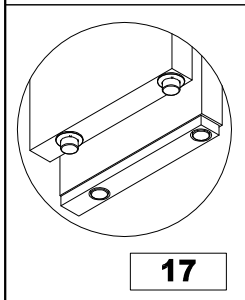
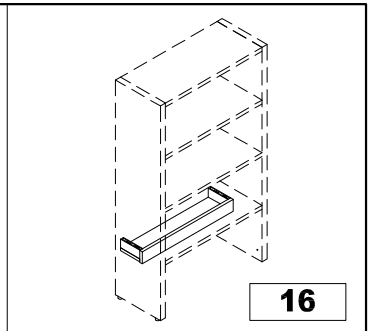
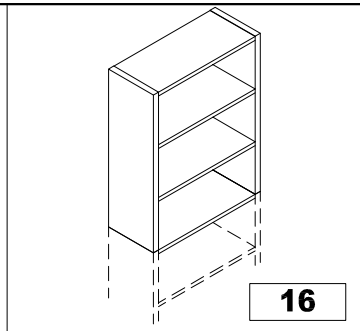
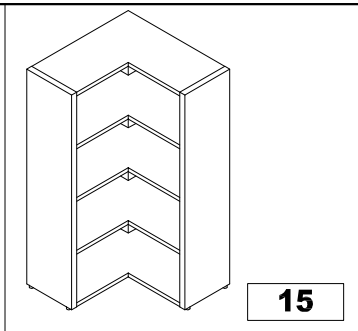
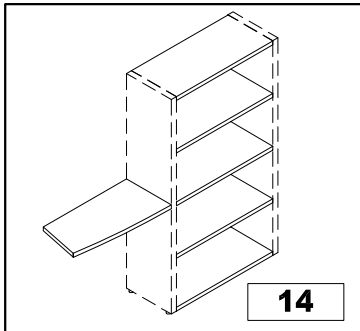
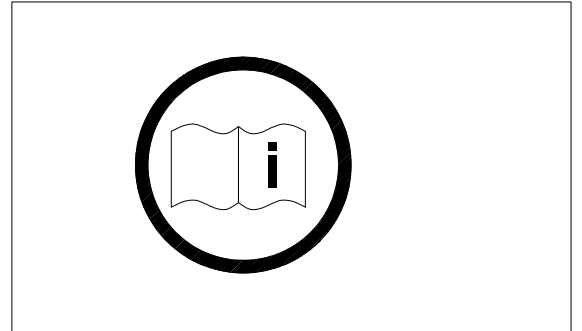
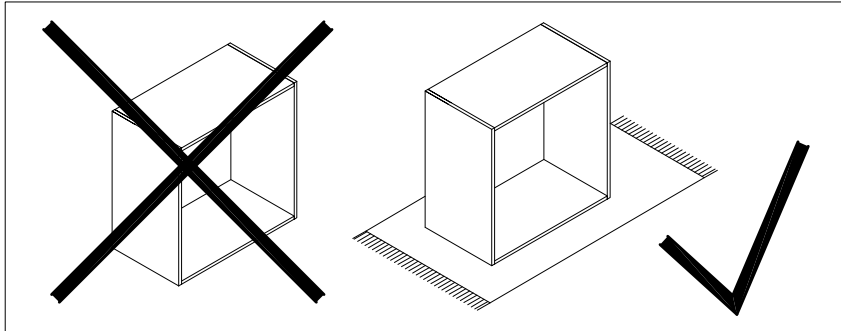
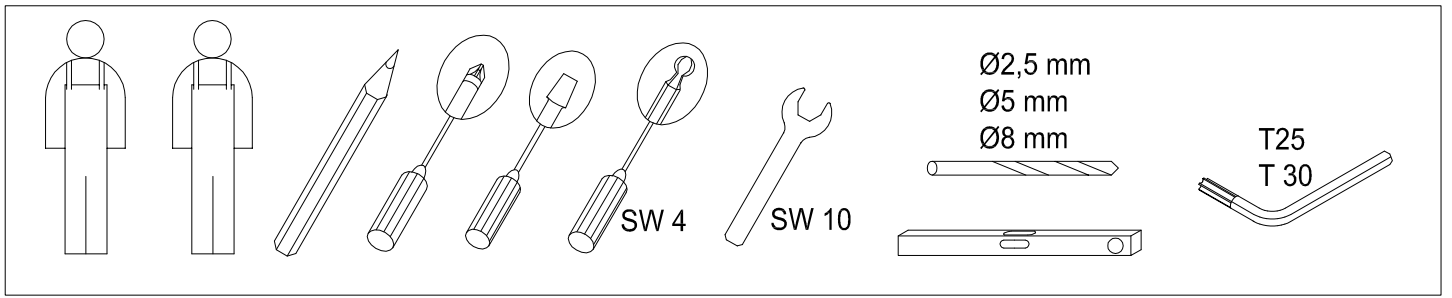

NURIA

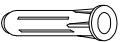
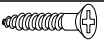

hülsta 





BB 521		Mat. 553883	
1x			
1x		5x60	
1x		6x45	
1x		Ø8 mm	
2x		3,5x25	
2x		3,5x17	

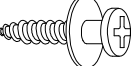

BB 847		Mat. 210138	
4x		Tab V 26	
4x		4x15	

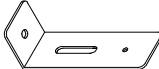
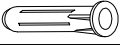
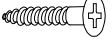

BB 1381		Mat. 1122971	
4x		4x16	

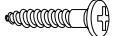
BB 1466		Mat. 1156136	
12x		4x35	

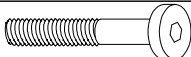
BB 1467		Mat. 1156137	
1x			
1x		Ø8 mm	
2x		3x20	
1x		5,5x50	



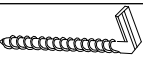

BB 1468		Mat. 1156138	
1x			
2x		4x17	

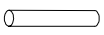
BB 1472		Mat. 1156142	
2x		M6x60	
2x		6,4 <small>DIN 125</small>	
2x			

BB 1476		Mat. 1160380	
1x		5,8x70	
1x		Ø8 mm	

BB 1512		Mat. 1173474	
1x			
10x		5x24	

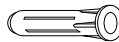
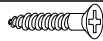

BB 2074		Mat. 1443279	
4x		Ø35x1,5	

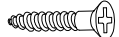
BB 521		Mat. 553883	
1x			
1x		5x60	
1x		6x45	
1x		Ø8 mm	
2x		3,5x25	
2x		3,5x17	

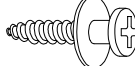

BB 847		Mat. 210138	
4x		Tab V 26	
4x		4x15	

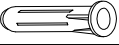

BB 1381		Mat. 1122971	
4x		4x16	

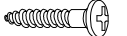
BB 1466		Mat. 1156136	
12x		4x35	

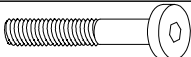
BB 1467		Mat. 1156137	
1x			
1x		Ø8 mm	
2x		3x20	
1x		5,5x50	

BB 1468		Mat. 1156138	
1x			
2x		4x17	

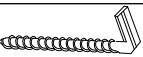



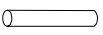







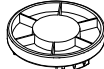







BB 1472		Mat. 1156142	
2x		M6x60	
2x		6,4 <small>DIN 125</small>	
2x			



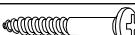
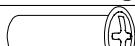
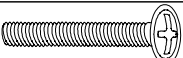
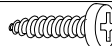

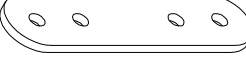
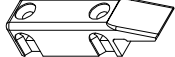







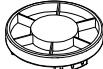



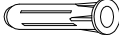

BB 1476		Mat. 1160380	
1x		5,8x70	
1x		Ø8 mm	

BB 1512		Mat. 1173474	
1x			
10x		5x24	

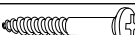
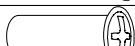
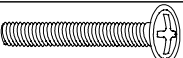
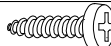
BB 2074		Mat. 1443279	
4x		Ø35x1,5	

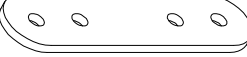
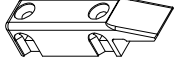

BB 2102		Mat. 1462719	
4x		4,5x14	
BB 2108		Mat. 1466224	
4x		5x25	
BB 2161		Mat. 1502078	
10x			
BB 2321/2322		Mat. 1546609/1546610	
2x/4x			
BB 2480		Mat. 1597775	
2x		Ø8 mm	
2x			
1x			
2x		6x70	
BB 2590		Mat. 1620492	
1x			
1x		5x60	
1x		6x45	
1x		Ø8 mm	
2x		3,5x25	
2x		3,5x17	
BB 2595		Mat. 1621277	
4x		4x35	
4x		M4x30	
2x		M4x55	
BB 2600		Mat. 1637539	
4x		3,5x17	
4x		3,5x25	
2x			
2x		6x70	
BB 2637		Mat. 1647608	
4x			
4x			
8x		3,5x25	

BB 2102		Mat. 1462719	
4x		4,5x14	
BB 2108		Mat. 1466224	
4x		5x25	
BB 2161		Mat. 1502078	
10x			
BB 2321/2322		Mat. 1546609/1546610	
2x/4x			
BB 2480		Mat. 1597775	
2x		Ø8 mm	
2x			
1x			
2x		6x70	
BB 2590		Mat. 1620492	
1x			
1x		5x60	
1x		6x45	
1x		Ø8 mm	
2x		3,5x25	
2x		3,5x17	
BB 2595		Mat. 1621277	
4x		4x35	
4x		M4x30	
2x		M4x55	
BB 2600		Mat. 1637539	
4x		3,5x17	
4x		3,5x25	
2x			
2x		6x70	
BB 2637		Mat. 1647608	
4x			
4x			
8x		3,5x25	



1



BB 2102

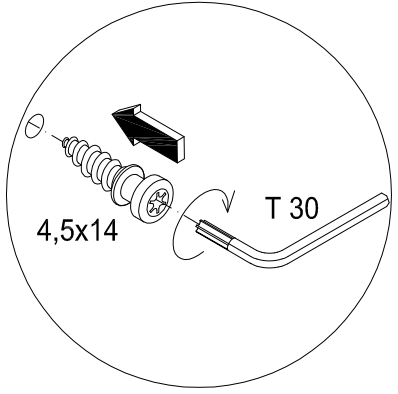
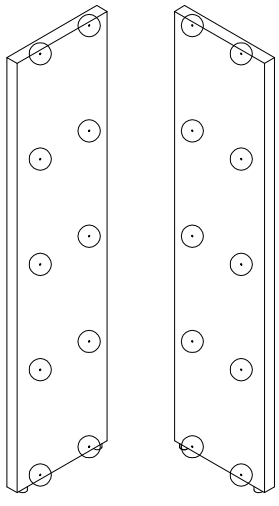

4,5x14

T 30

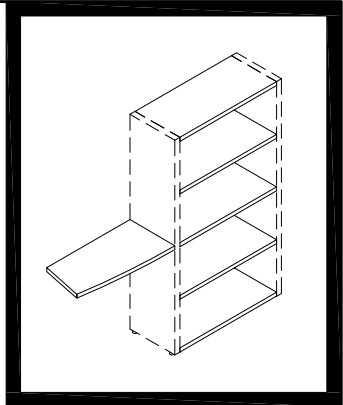

(2)

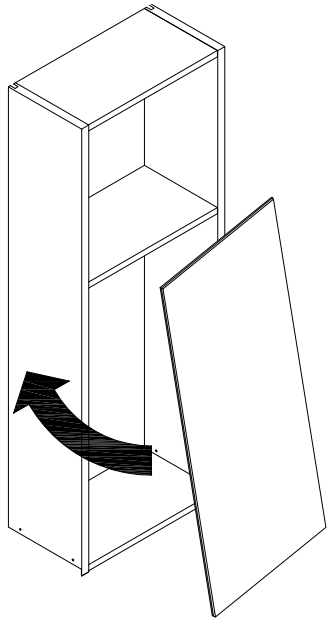

3

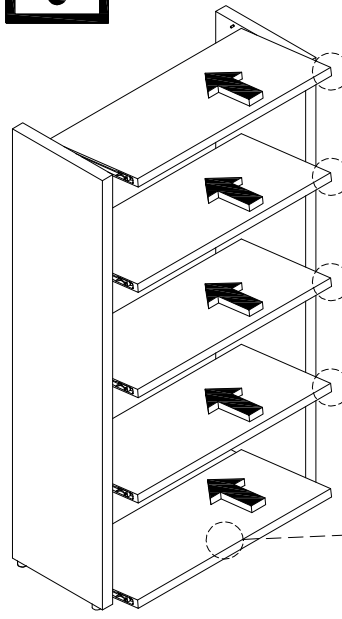

3.1

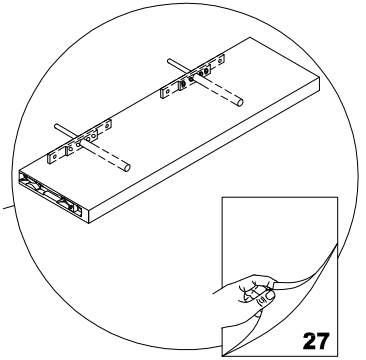

27

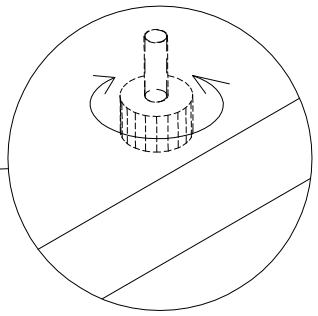

3.2

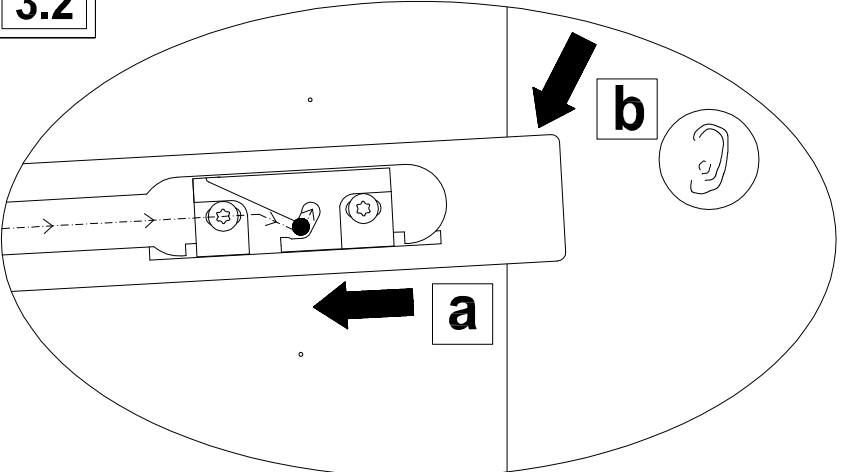

b

a

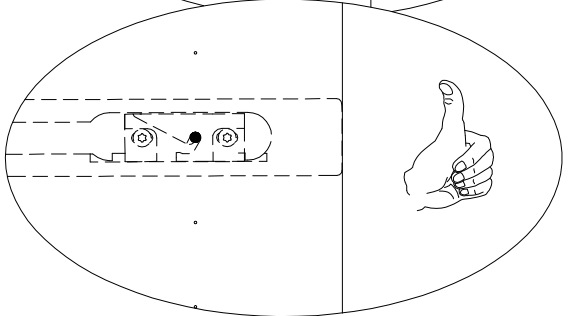
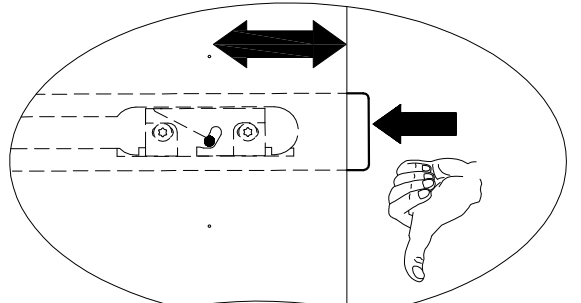

1

BB 2102

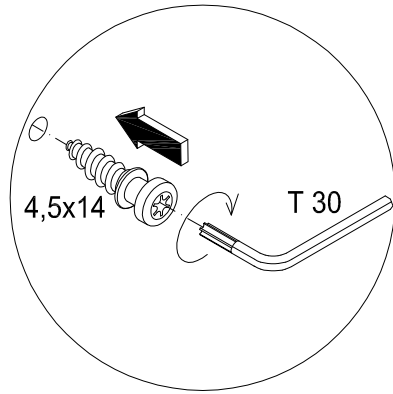
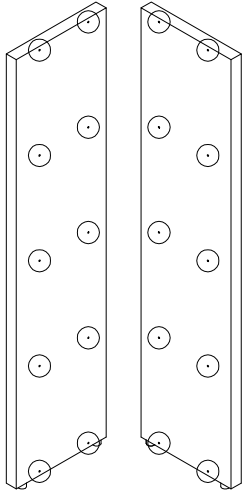

2

BB 847

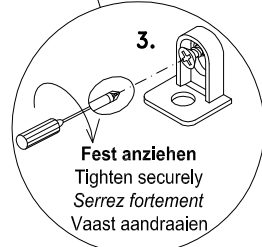
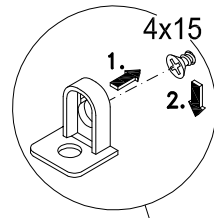
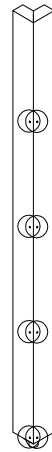

Fest anziehen
Tighten securely
Serrez fortement
Vaast aandraaien

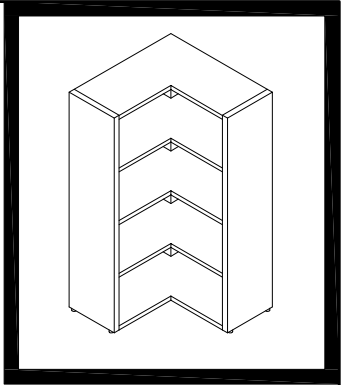

3

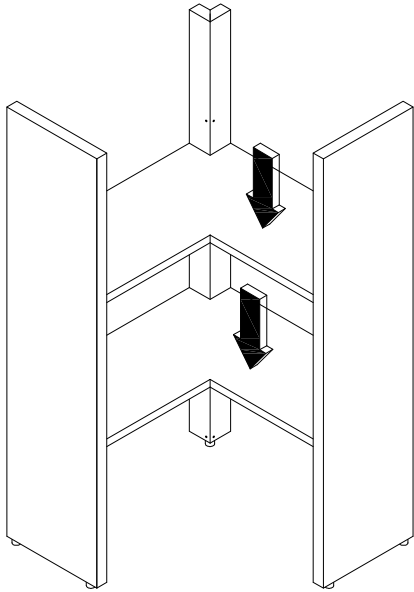

4

Bodenverriegelung
Locking of shelf
Verrouillage de la tablette
Plankbevestiging

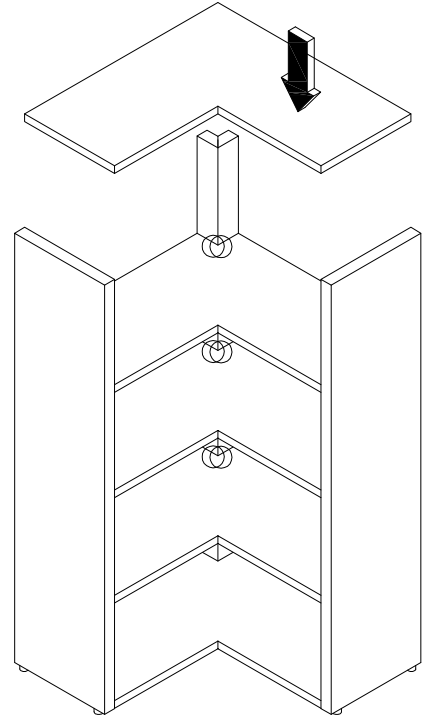
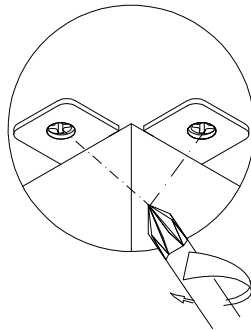

5

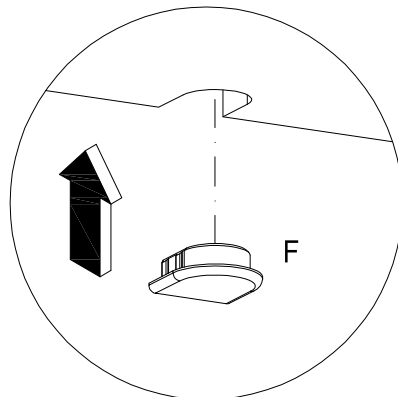
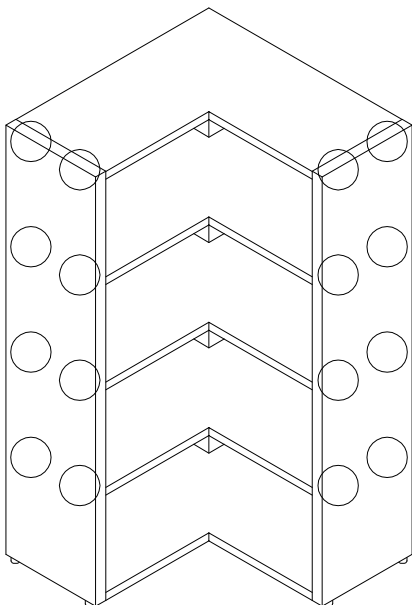

1

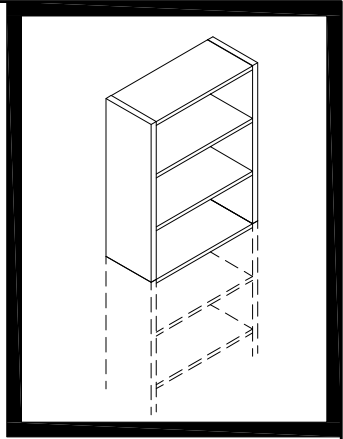
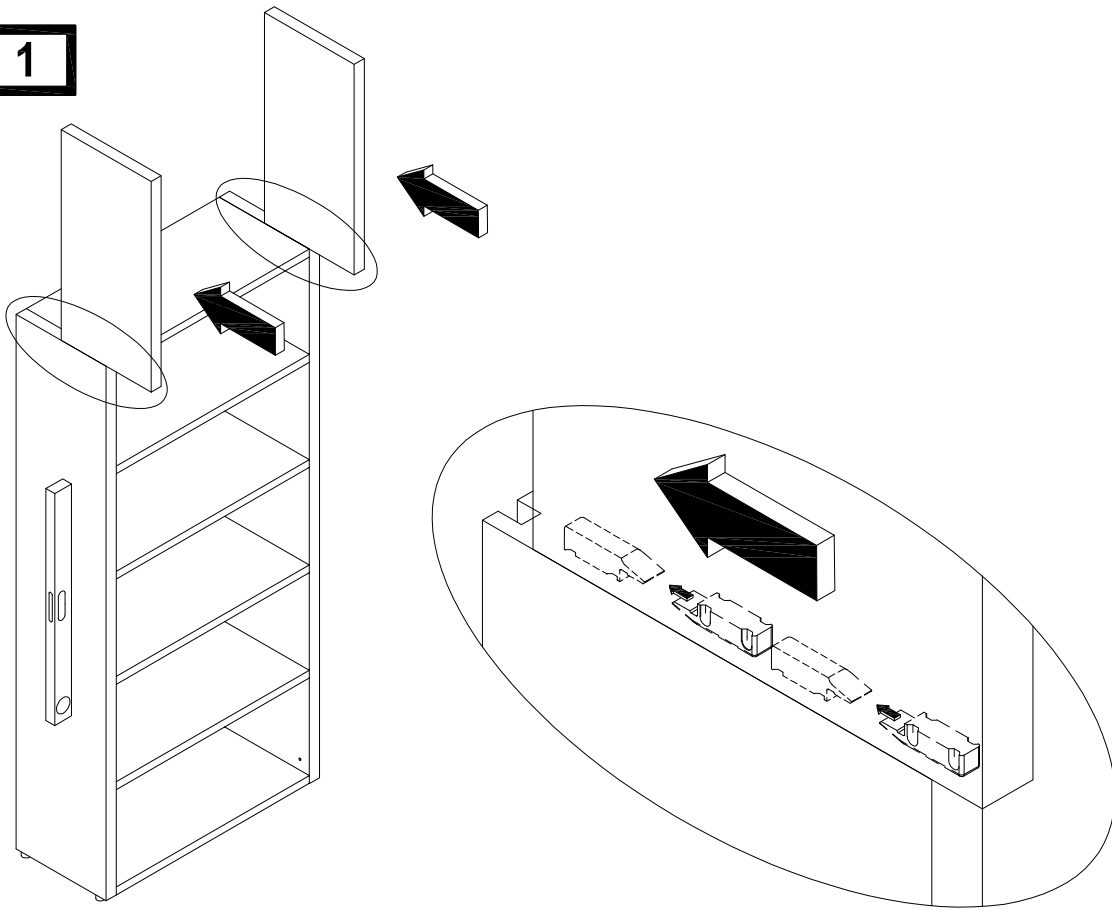

1

BB 2637

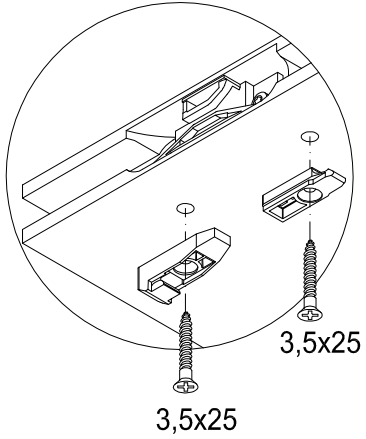
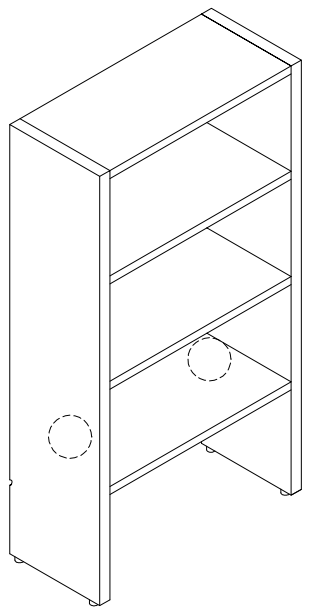

2

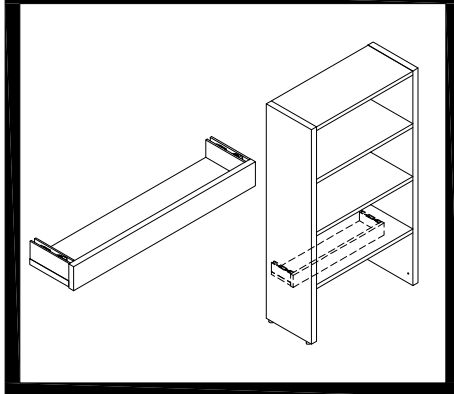
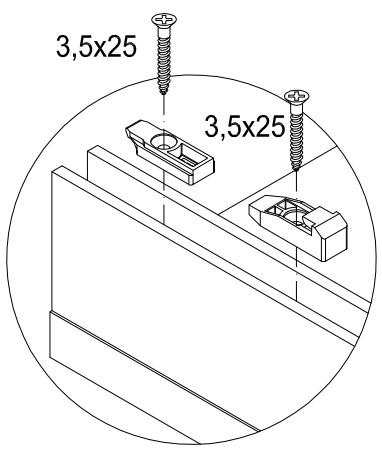
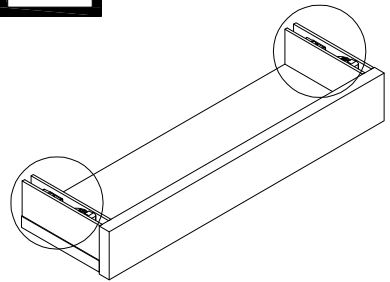

3

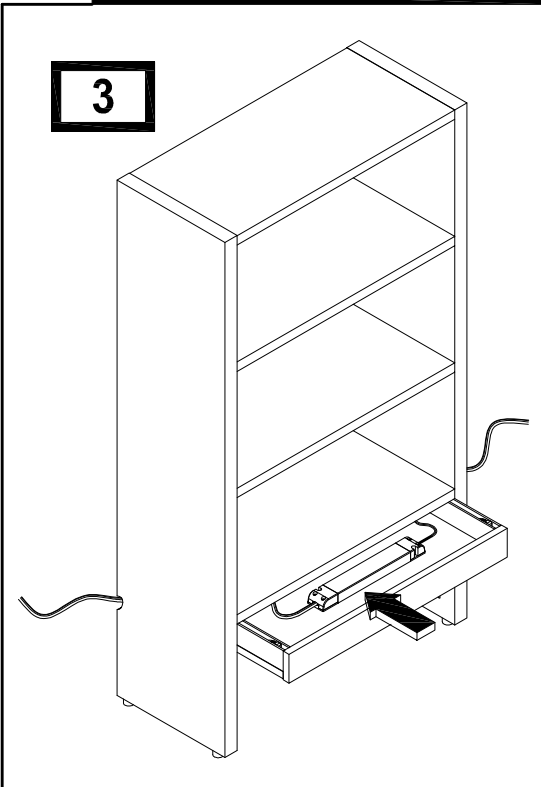

1

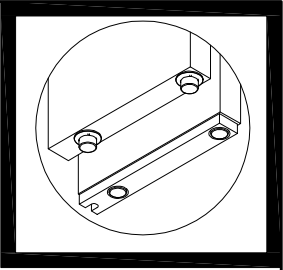
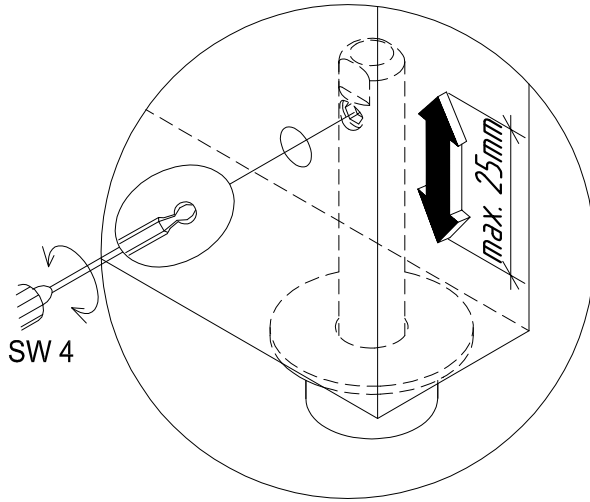
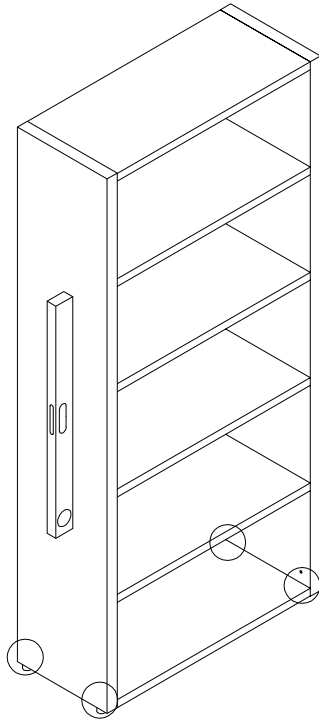

3

Decke

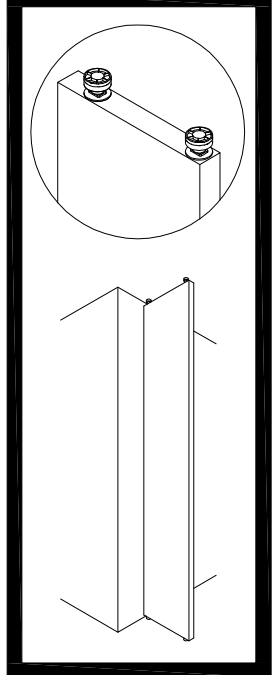
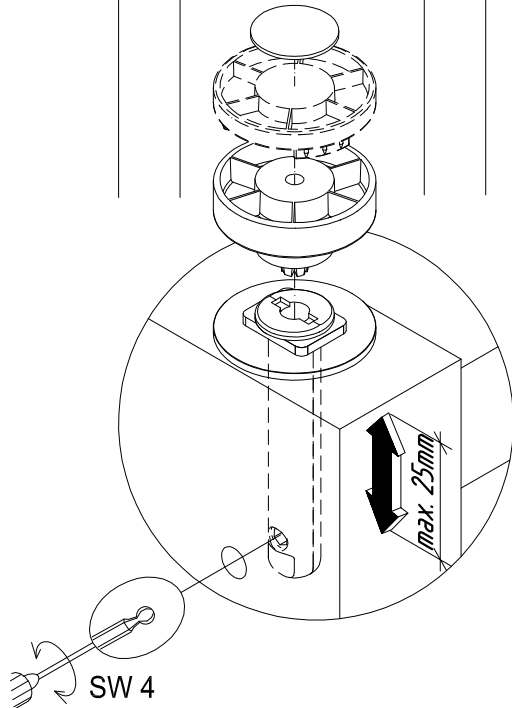
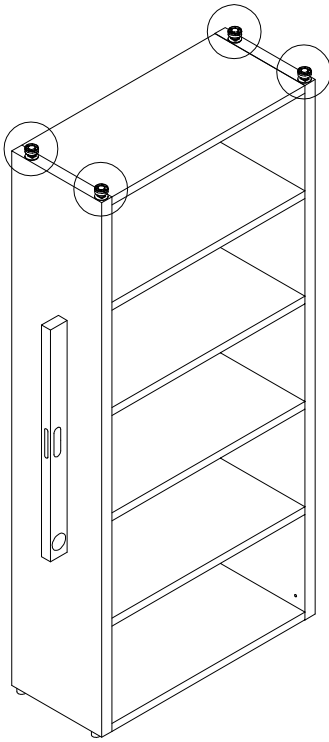
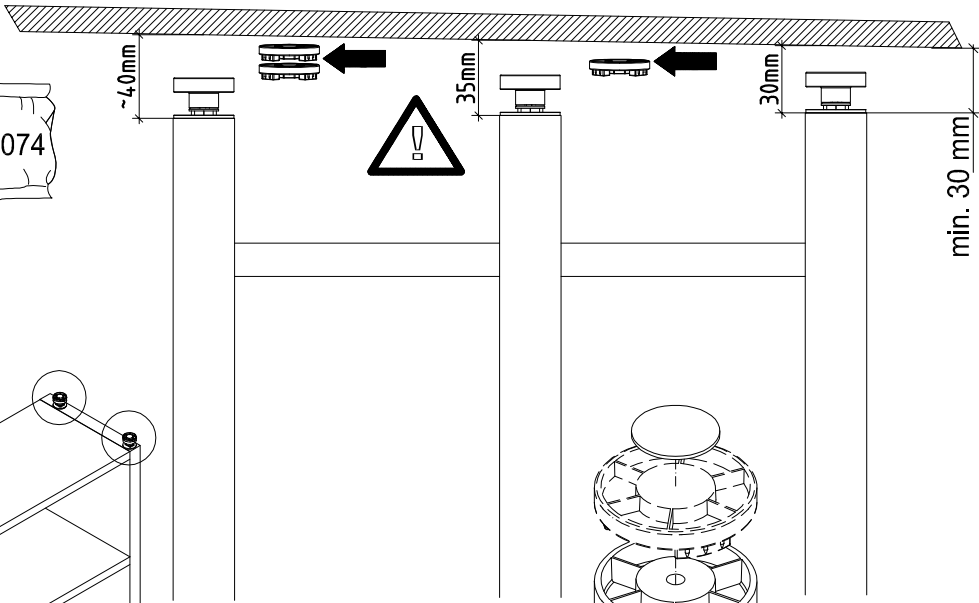
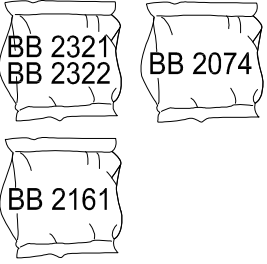

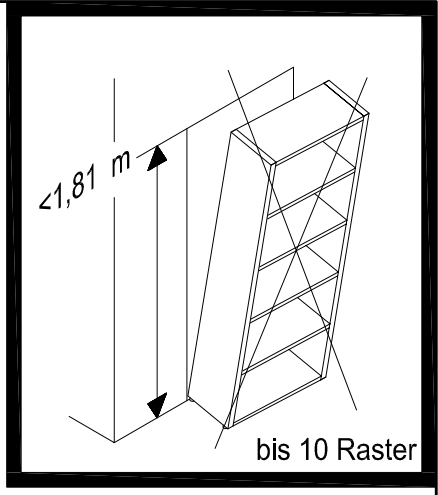
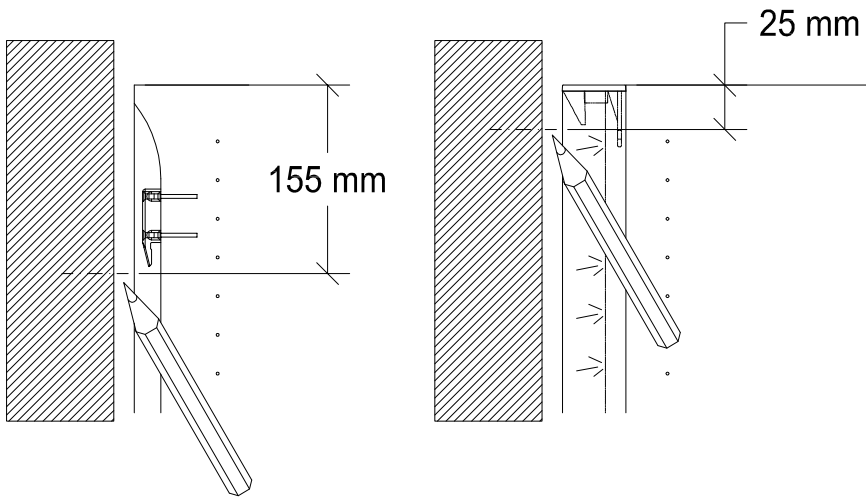
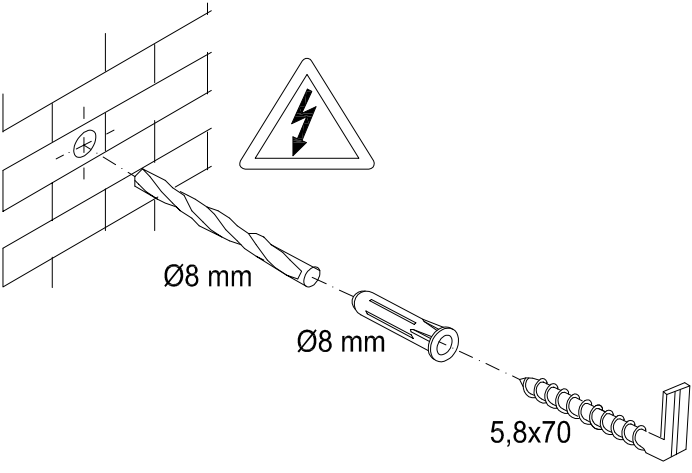
1**2**

Wandbefestigung - Achtung! Die Wandbeschaffenheit ist vor der Montage unbedingt zu prüfen. Verwendung von Dübeln bei Beton und/oder festem Mauerwerk. Bei abweichender Beschaffenheit (z.B. Rahmenbauweise mit Gipskartonplatten, Leichtbausteinen etc.) ist eine andere, der Belastung angemessene Befestigung bauseits vorzunehmen. Beachten Sie, dass in dem Befestigungsbereich keine Elektro-Installationszonen und keine Ver- oder Entsorgungsleitungen vorhanden sein dürfen. Prüfen Sie mit einem geeigneten Leitungssuchgerät. Beachten Sie, dass Kunststoffrohre nicht dedektiert werden.

Wall mounting - Please note! Please be sure to test the soundness of walls beforehand. Use plugs for concrete and solid walls. Use a different method that is capable of withstanding the load for lighter types of walls (e.g. framed gypsum plaster board, light brickwork, etc.). Please note that there must not be any electrical installations nor any electrical connections or leads of any kind in the assembly area. Please ensure this is so by testing the area with a suitable electrical leads search device. Please also note that plastic tubing will not be detected.

Fixation murale - Attention! La composition du mur doit absolument être contrôlée. Utilisation de chevilles pour le béton et/ou la maçonnerie dure. Pour les autres types de construction (cloisons en placoplâtre, maçonnerie légère, etc...), il faut prévoir un autre mode de fixation en rapport avec la charge. Veuillez contrôler l'absence d'installations électriques et de conduits dans le secteur de la fixation à l'aide d'un appareil. Veuillez noter que les tubes en matière synthétiques ne sont pas détectés.

Bevestiging aan de muur - Attentie! Controleer, alvorens te beginnen, altijd de aard en de kwaliteit van de muur, waaraan gemonteerd moet worden. Gebruik voor de bevestiging aan beton en schoon metselwerk de door hülsta meegeleverde standaard pluggen en passende schroeven. In geval van muren van een ander, lichter soort materiaal (bijv. gipsplaten op een raamwerk of lichte bouwstenen) moet een ander, aan het draagvermogen aangepast speciaal bevestigingsmateriaal gebruikt worden. N.B.! In het muurgedeelte waar gemonteerd moet worden, mogen zich geen elektro-installatiezones bevinden resp. mogen geen aan- en/of afvoerleidingen (buizen) lopen. Dit kan gecontroleerd worden met speciale daarvoor bestemde detectieapparatuur. N.B.! Kunststofleidingen kunnen helaas niet worden gedetecteerd.

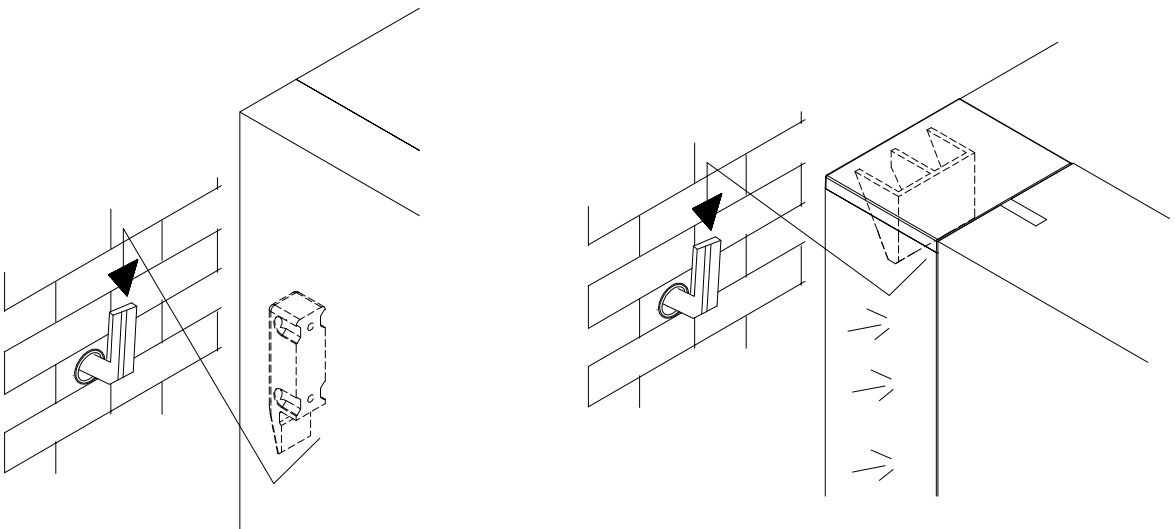
3

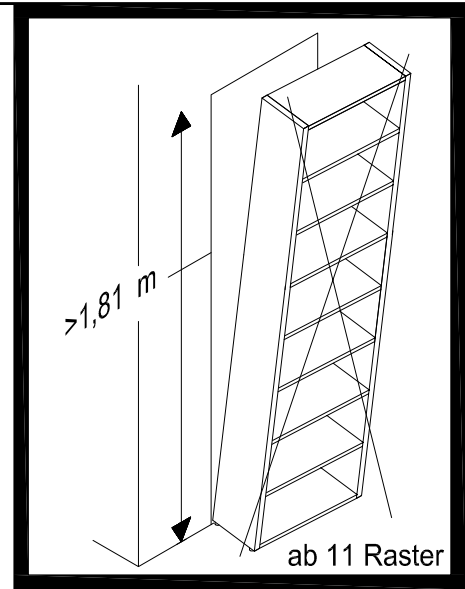
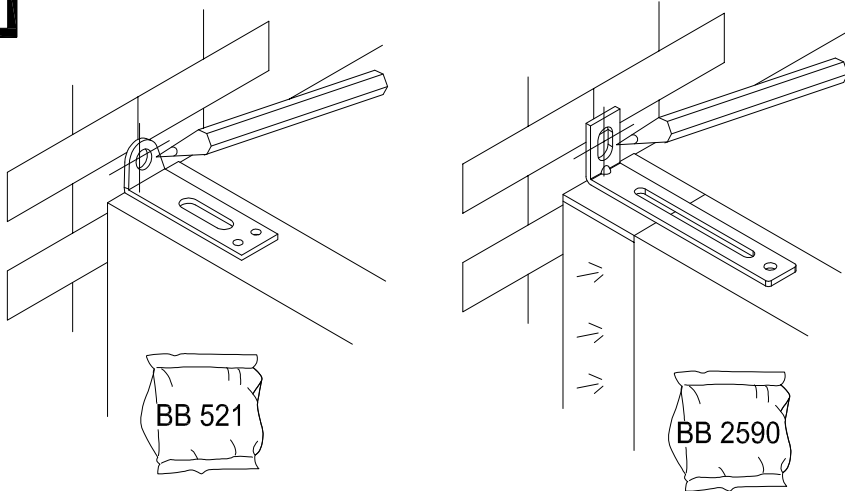
1**2**

Wandbefestigung - Achtung! Die Wandbeschaffenheit ist vor der Montage unbedingt zu prüfen. Verwendung von Dübeln bei Beton und/oder festem Mauerwerk. Bei abweichender Beschaffenheit (z.B. Rahmenbauweise mit Gipskartonplatten, Leichtbausteinen etc.) ist eine andere, der Belastung angemessene Befestigung bauseits vorzunehmen. Beachten Sie, dass in dem Befestigungsbereich keine Elektro-Installationszonen und keine Ver- oder Entsorgungsleitungen vorhanden sein dürfen. Prüfen Sie mit einem geeigneten Leitungssuchgerät. Beachten Sie, dass Kunststoffrohre nicht dedektiert werden.

Wall mounting - Please note! Please be sure to test the soundness of walls beforehand. Use plugs for concrete and solid walls. Use a different method that is capable of withstanding the load for lighter types of walls (e.g. framed gypsum plaster board, light brickwork, etc.). Please note that there must not be any electrical installations nor any electrical connections or leads of any kind in the assembly area. Please ensure this is so by testing the area with a suitable electrical leads search device. Please also note that plastic tubing will not be detected.

Fixation murale - Attention! La composition du mur doit absolument être contrôlée. Utilisation de chevilles pour le béton et/ou la maçonnerie dure. Pour les autres types de construction (cloisons en placoplâtre, maçonnerie légère, etc...), il faut prévoir un autre mode de fixation en rapport avec la charge. Veuillez contrôler l'absence d'installations électriques et de conduits dans le secteur de la fixation à l'aide d'un appareil. Veuillez noter que les tubes en matière synthétiques ne sont pas détectés.

Bevestiging aan de muur - Attentie! Controleer, alvorens te beginnen, altijd de aard en de kwaliteit van de muur, waaraan gemonteerd moet worden. Gebruik voor de bevestiging aan beton en schoon metselwerk de door hülsta meegeleverde standaard pluggen en passende schroeven. In geval van muren van een ander, lichter soort materiaal (bijv. gipsplaten op een raamwerk of lichte bouwstenen) moet een ander, aan het draagvermogen aangepast speciaal bevestigingsmateriaal gebruikt worden. N.B.! In het muurgedeelte waar gemonteerd moet worden, mogen zich geen elektro-installatiezones bevinden resp. mogen geen aan- en/of afvoerleidingen (buizen) lopen. Dit kan gecontroleerd worden met speciale daarvoor bestemde detectieapparatuur. N.B.! Kunststofleidingen kunnen helaas niet worden gedetecteerd.

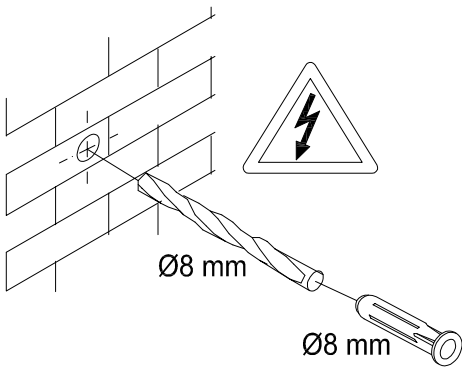
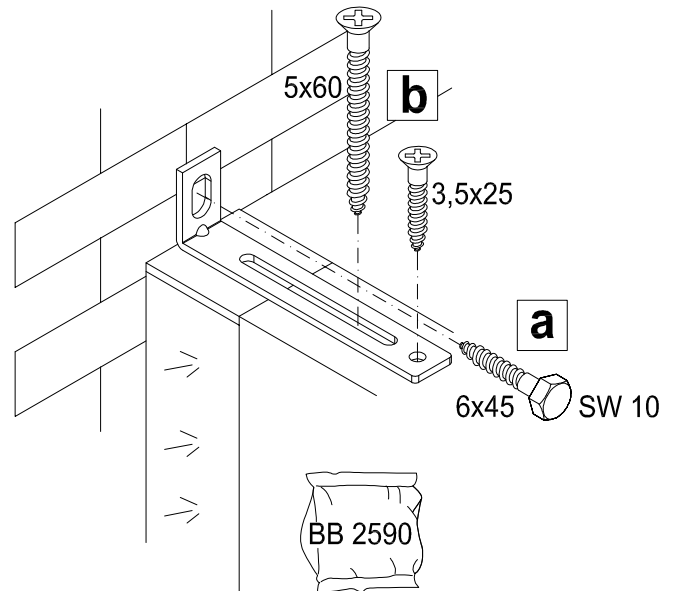
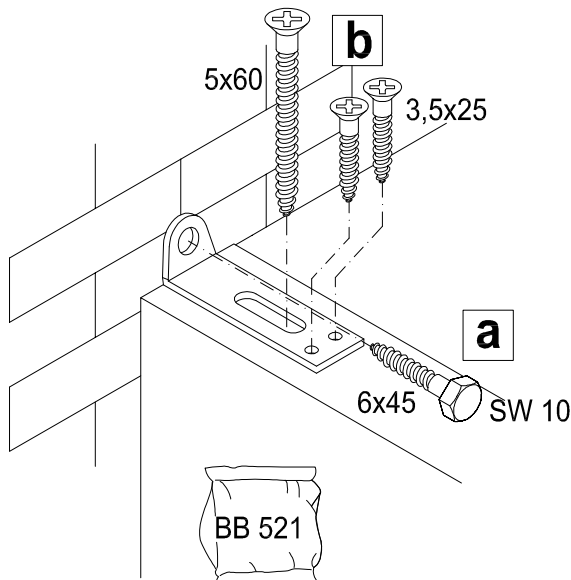
**3**

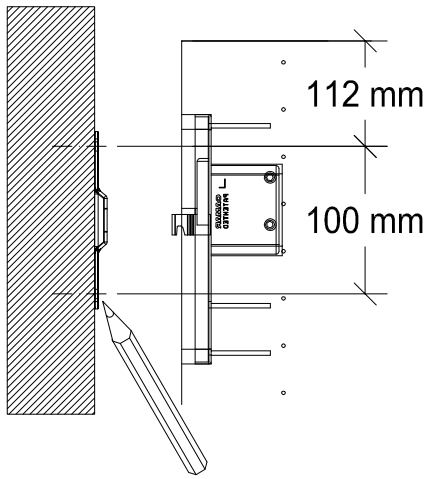
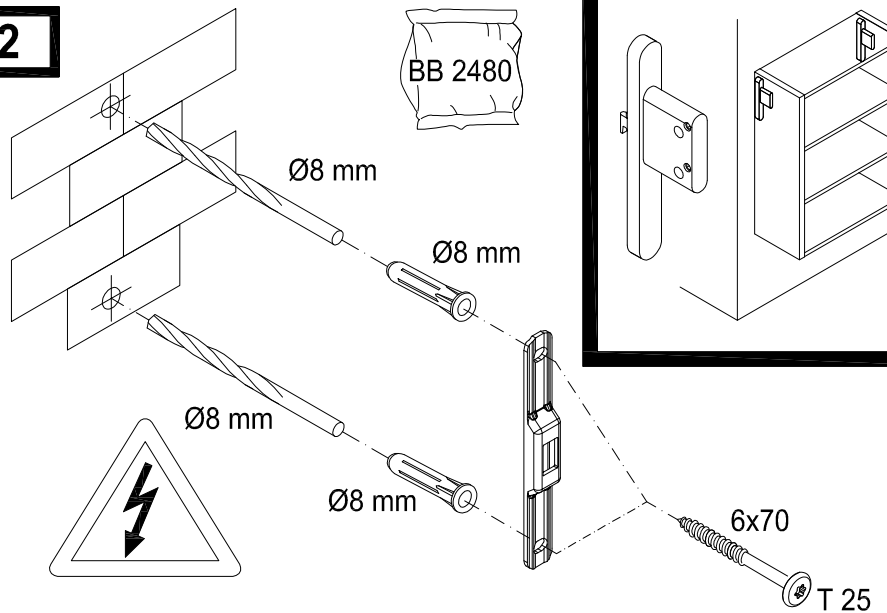
1**2**

Wandbefestigung - Achtung! Die Wandbeschaffenheit ist vor der Montage unbedingt zu prüfen. Verwendung von Dübeln bei Beton und/oder festem Mauerwerk. Bei abweichender Beschaffenheit (z.B. Rahmenbauweise mit Gipskartonplatten, Leichtbausteinen etc.) ist eine andere, der Belastung angemessene Befestigung bauseits vorzunehmen. Beachten Sie, dass in dem Befestigungsbereich keine Elektro-Installationszonen und keine Ver- oder Entsorgungsleitungen vorhanden sein dürfen. Prüfen Sie mit einem geeigneten Leitungssuchgerät. Beachten Sie, dass Kunststoffrohre nicht dedektiert werden.

Wall mounting - Please note! Please be sure to test the soundness of walls beforehand. Use plugs for concrete and solid walls. Use a different method that is capable of withstanding the load for lighter types of walls (e.g. framed gypsum plaster board, light brickwork, etc.). Please note that there must not be any electrical installations nor any electrical connections or leads of any kind in the assembly area. Please ensure this is so by testing the area with a suitable electrical leads search device. Please also note that plastic tubing will not be detected.

Fixation murale - Attention! La composition du mur doit absolument être contrôlée. Utilisation de chevilles pour le béton et/ou la maçonnerie dure. Pour les autres types de construction (cloisons en placoplâtre, maçonnerie légère, etc...), il faut prévoir un autre mode de fixation en rapport avec la charge. Veuillez contrôler l'absence d'installations électriques et de conduits dans le secteur de la fixation à l'aide d'un appareil. Veuillez noter que les tubes en matière synthétiques ne sont pas détectés.

Bevestiging aan de muur - Attentie! Controleer, alvorens te beginnen, altijd de aard en de kwaliteit van de muur, waaraan gemonteerd moet worden. Gebruik voor de bevestiging aan beton en schoon metselwerk de door hülsta meegeleverde standaard pluggen en passende schroeven. In geval van muren van een ander, lichter soort materiaal (bijv. gipsplaten op een raamwerk of lichte bouwstenen) moet een ander, aan het draagvermogen aangepast speciaal bevestigingsmateriaal gebruikt worden. N.B.! In het muurgedeelte waar gemonteerd moet worden, mogen zich geen elektro-installatiezones bevinden resp. mogen geen aan- en/of afvoerleidingen (buizen) lopen. Dit kan gecontroleerd worden met speciale daarvoor bestemde detectieapparatuur. N.B.! Kunststoffleidingen kunnen helaas niet worden gedetecteerd.

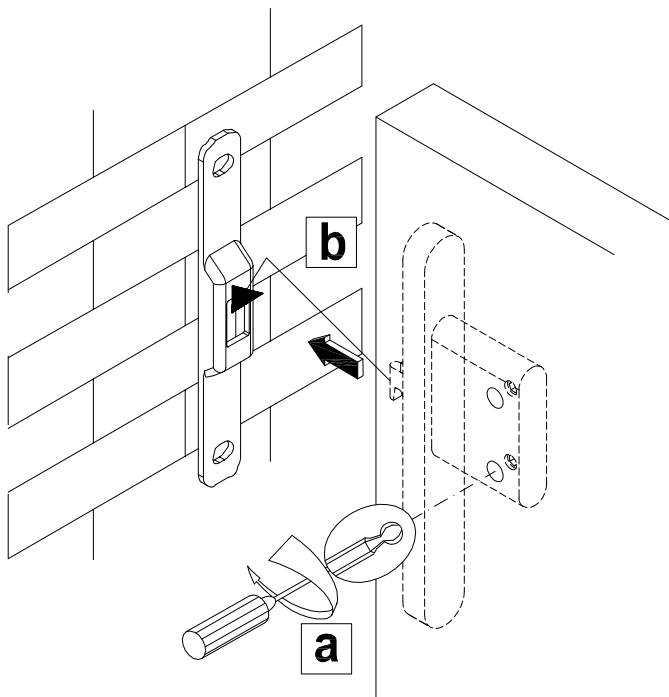
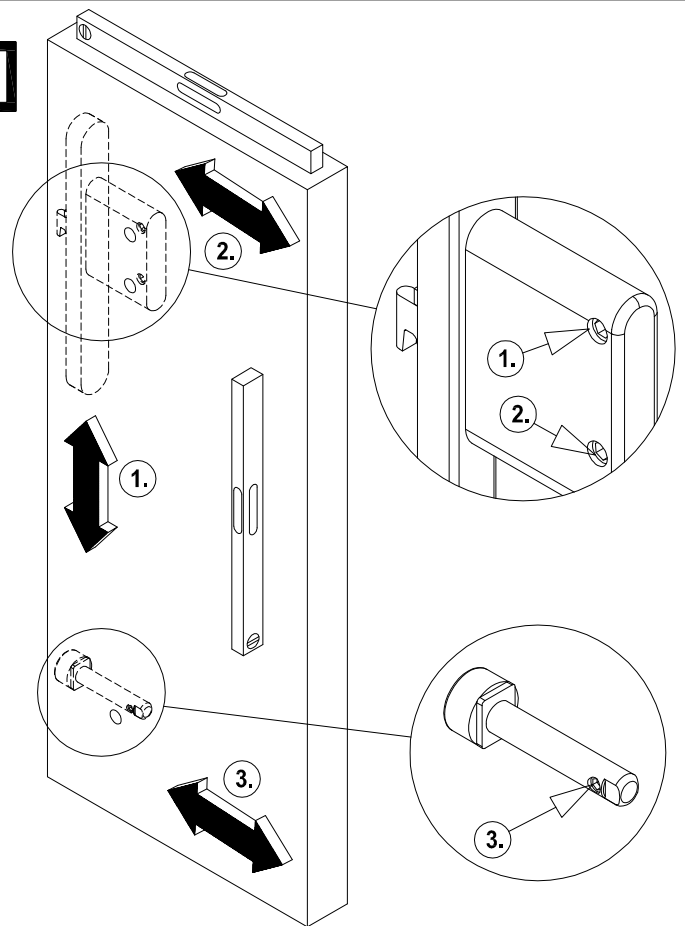
3**4**

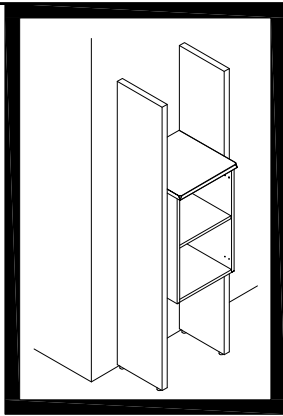

1

BB 2108

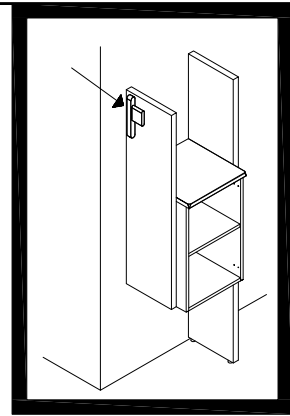
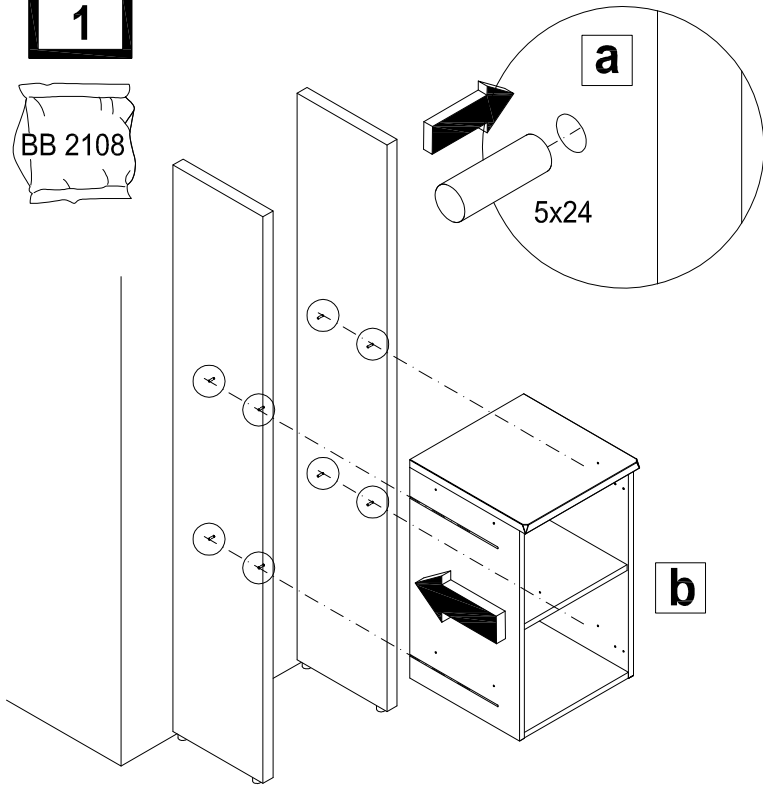

1

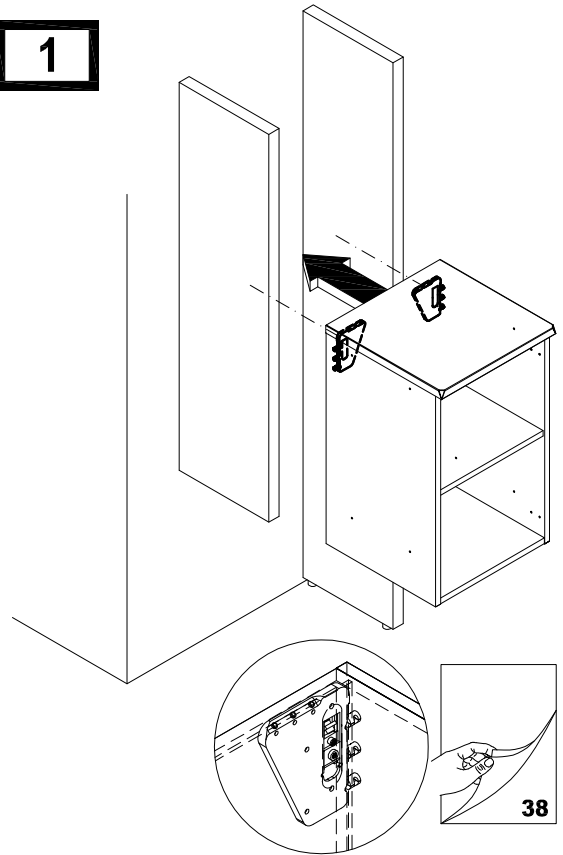

2

BB 1466

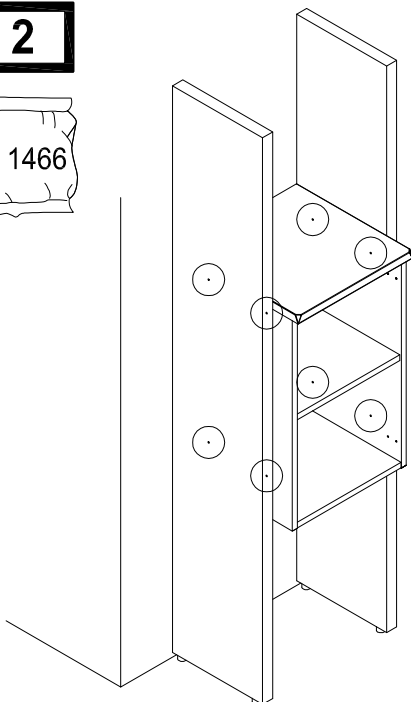

2

BB 1466

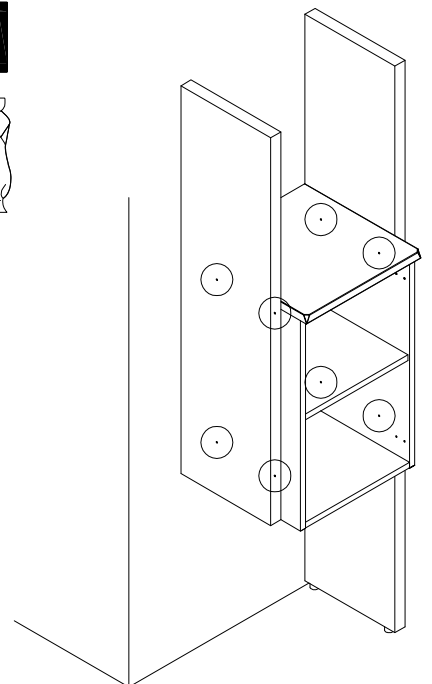
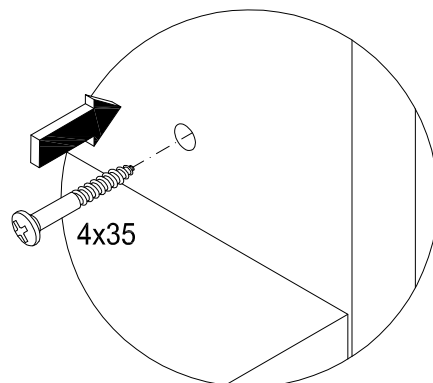

1

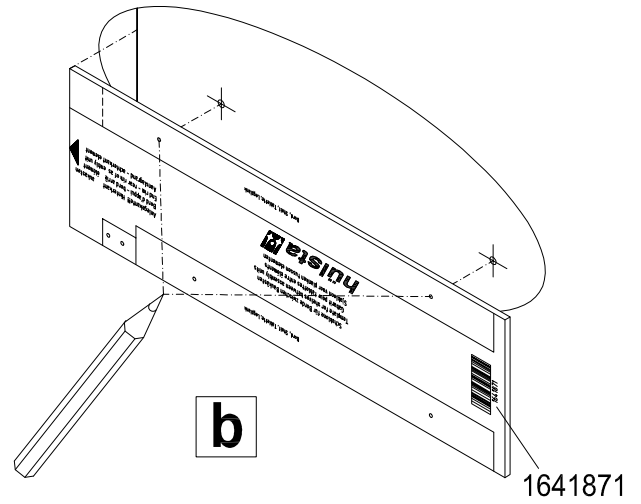
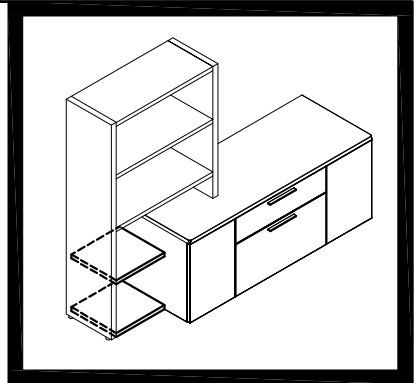
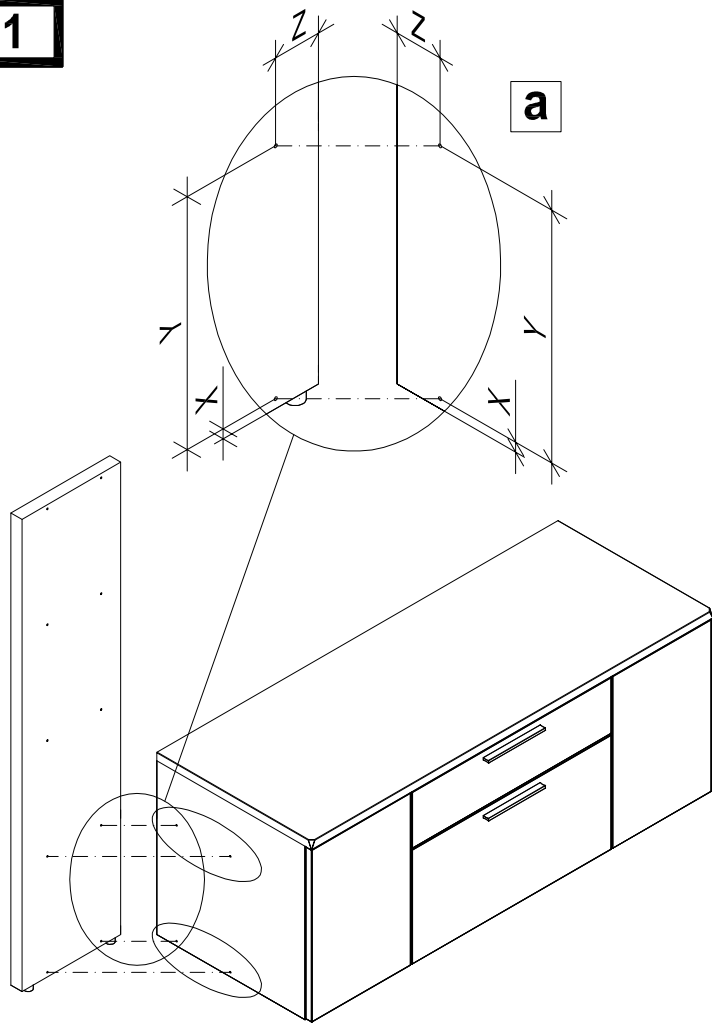

2

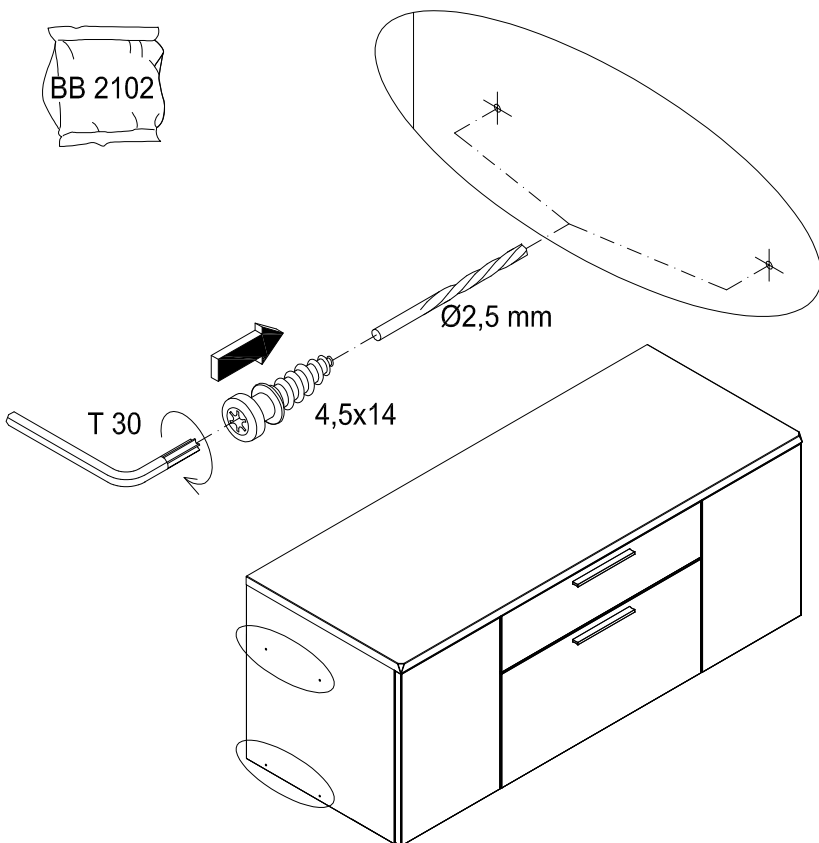

3

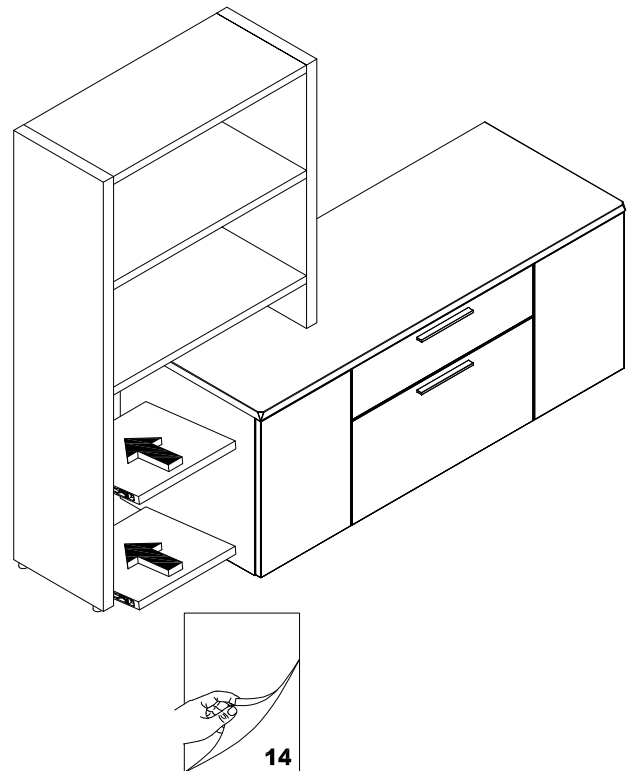

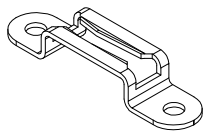
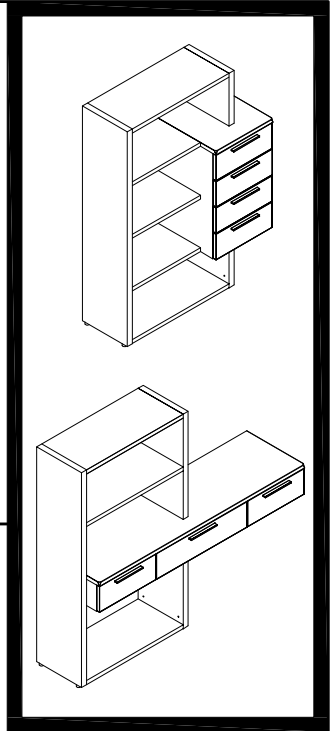
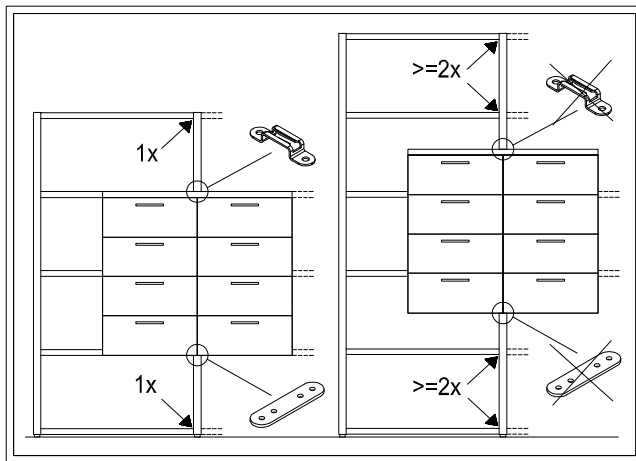
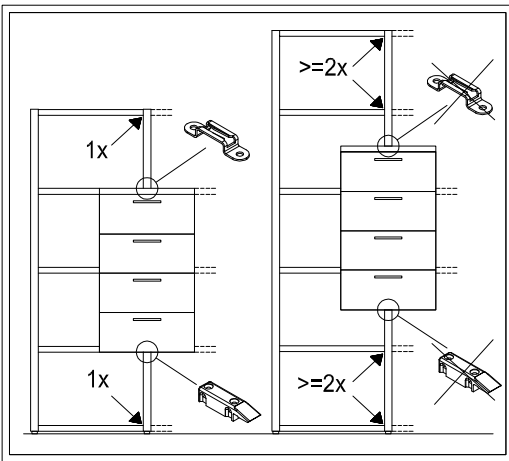

1

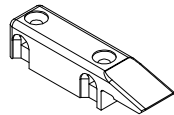
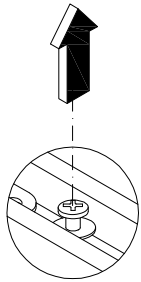
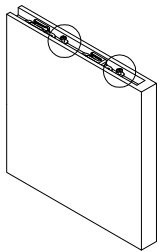

1

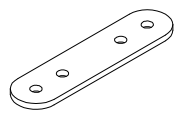
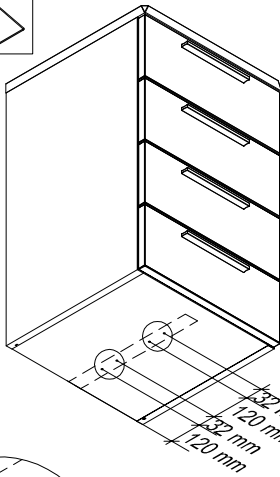

1

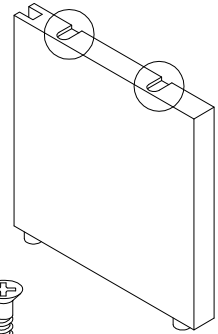

2

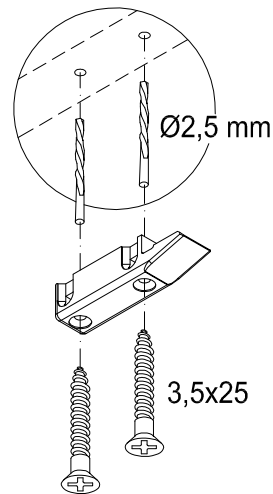
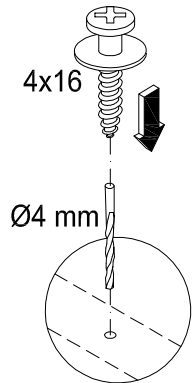
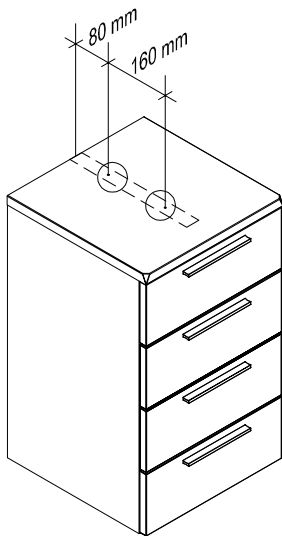

3,5x25

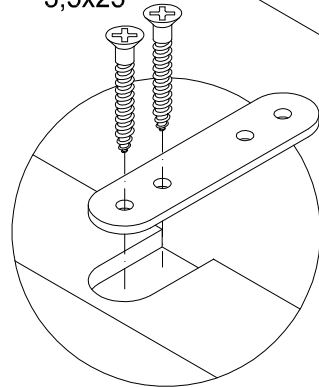

3

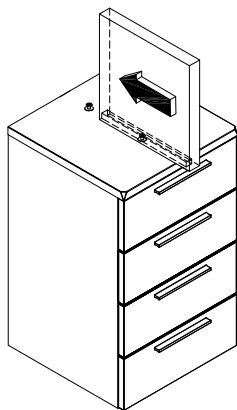

2

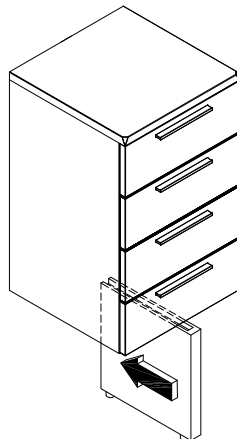

2

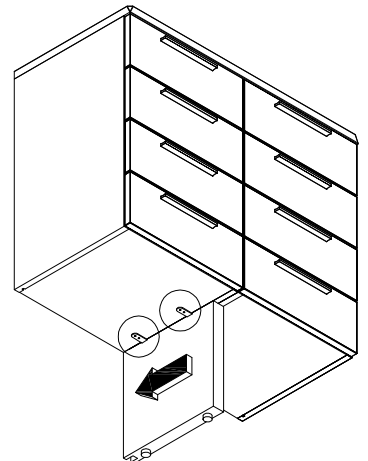

1

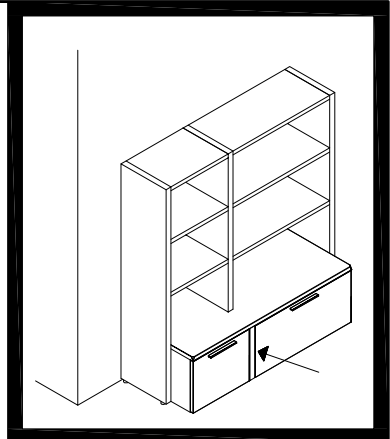
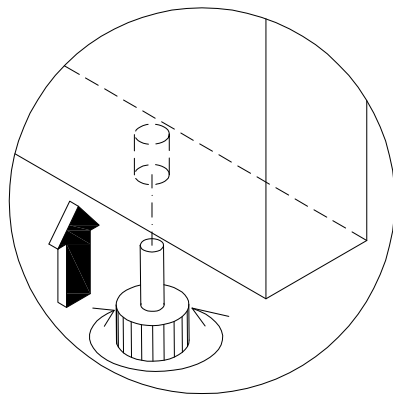
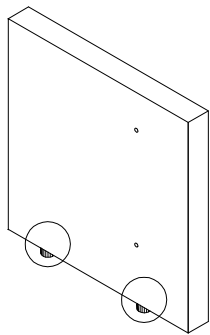

2

BB 2595

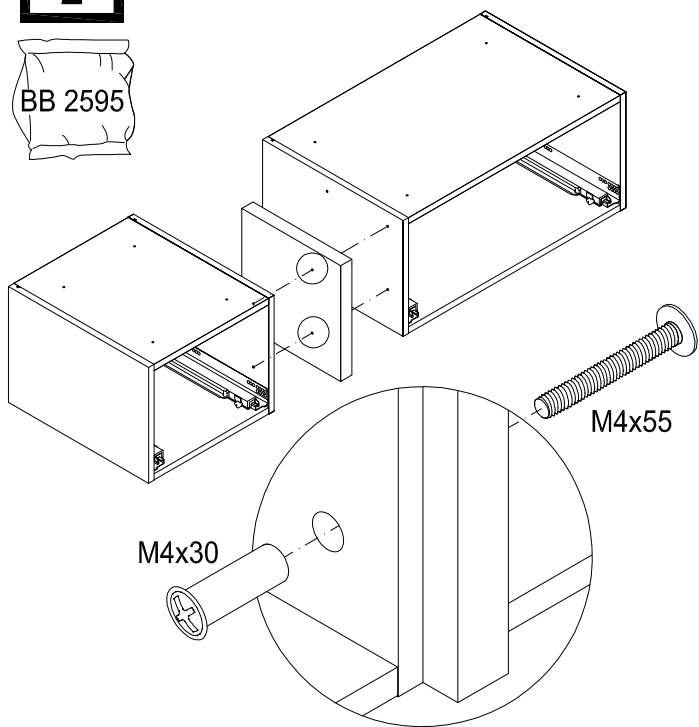

M4x55

M4x30

3

BB 2595

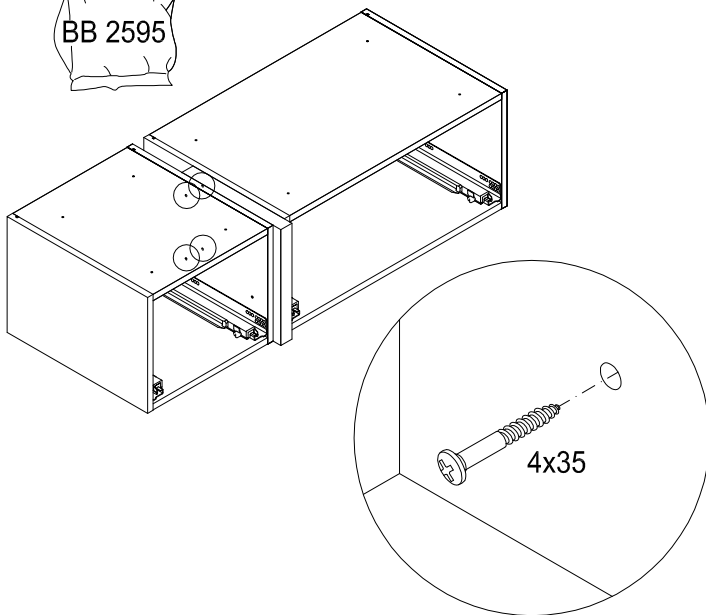

4x35

4

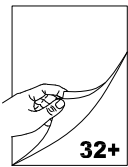

32+

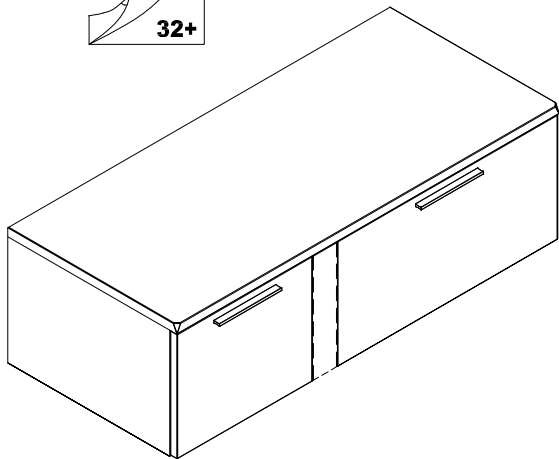

5

BB 1466

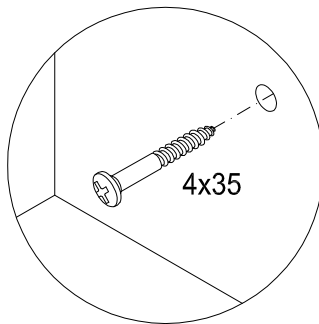

4x35

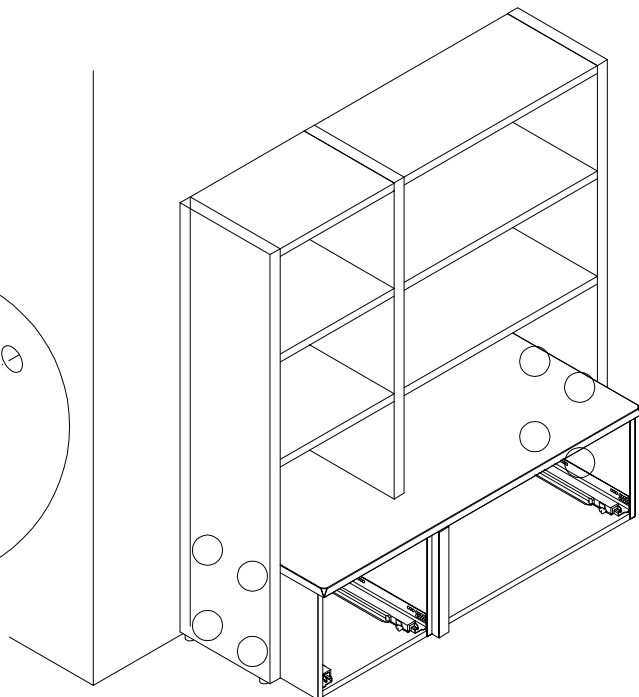

1

BB 1467

BB 1381

3x20

4x16

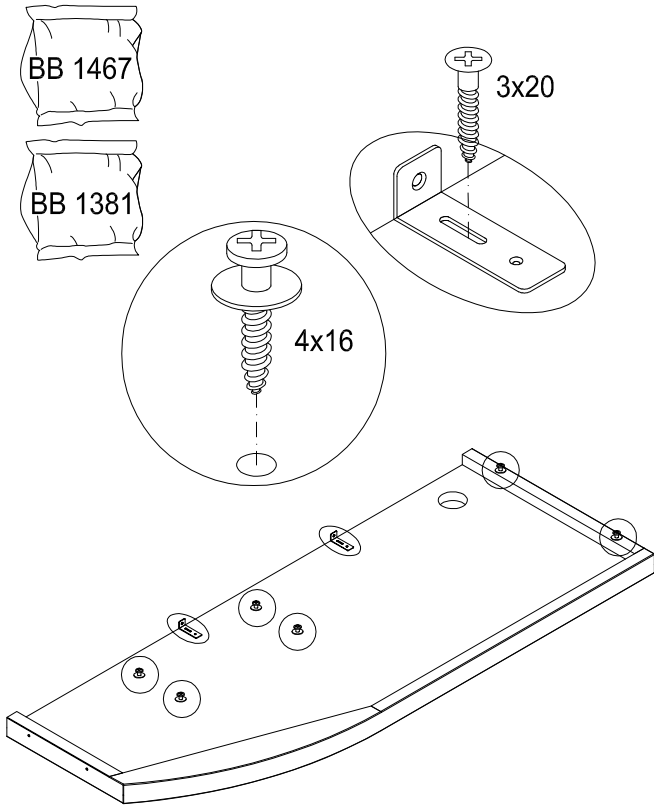

2

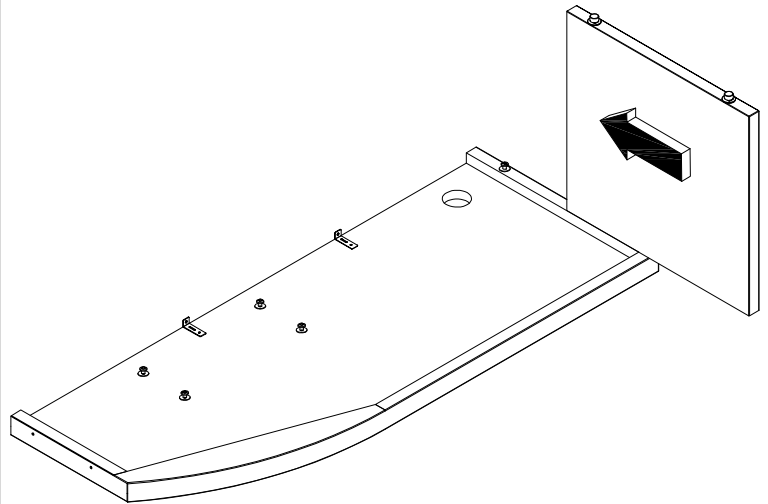
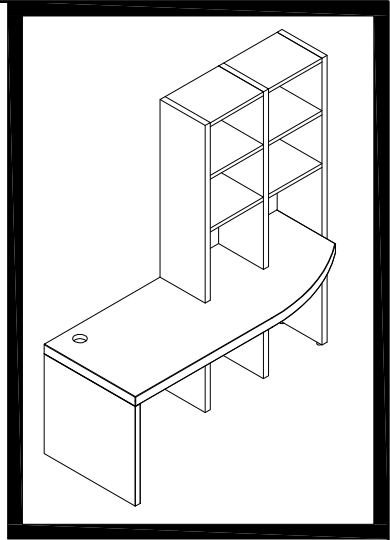

3

BB 1472

M6x60

SW 4

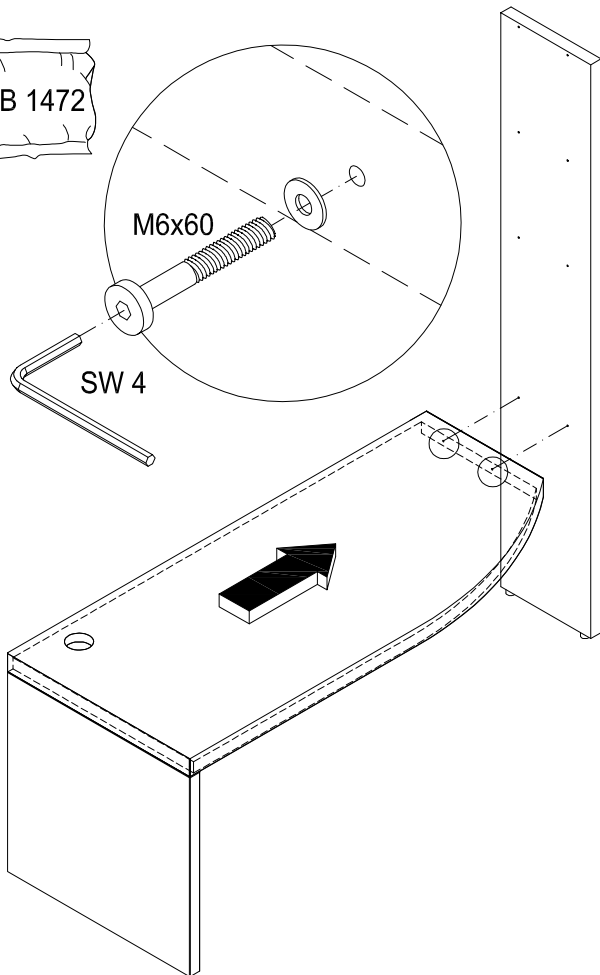

BB 1472

M6x60

SW 4

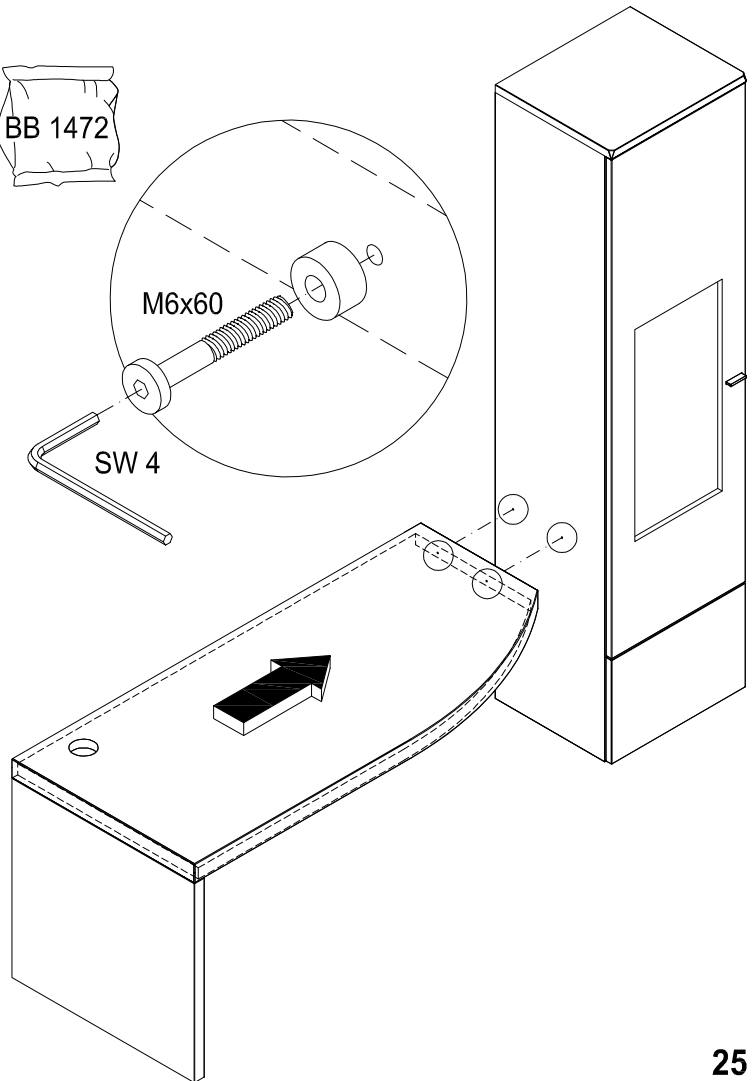

4

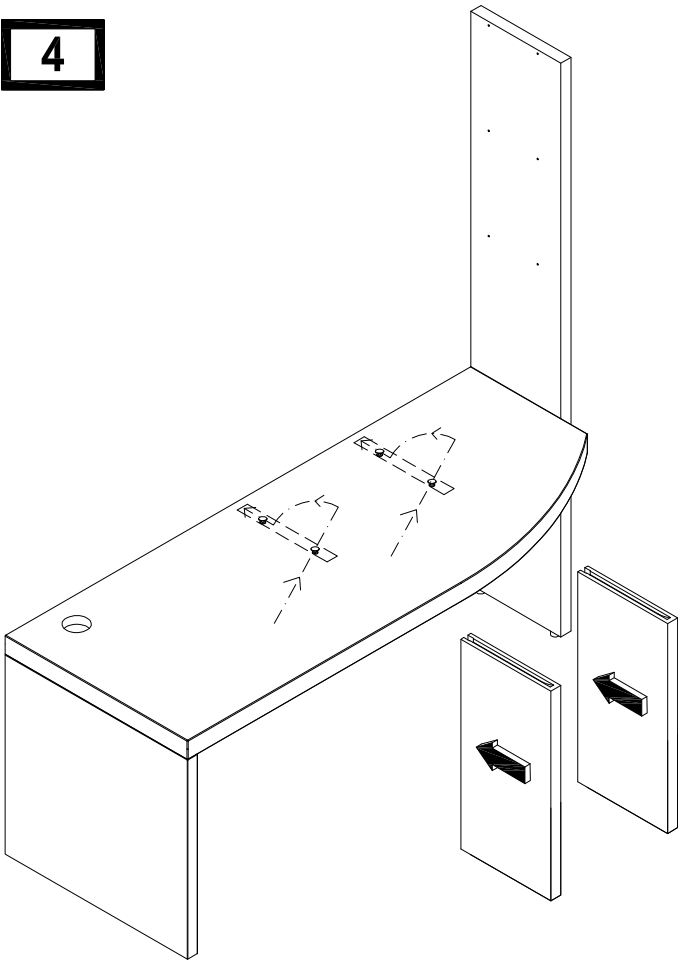

5

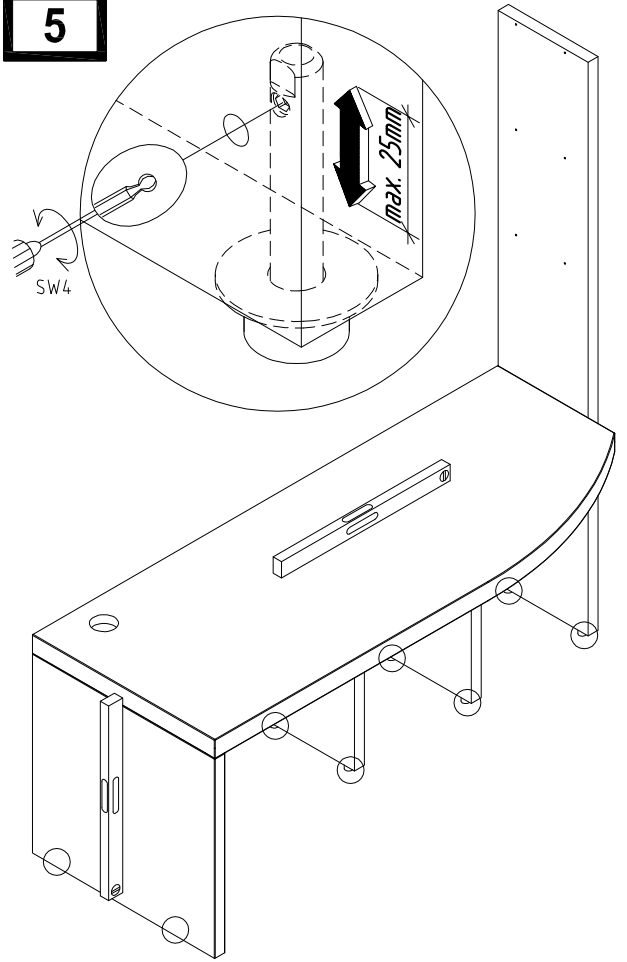

6

BB 1467

a

5,5x50

Ø8 mm

Ø8 mm

3x20

b

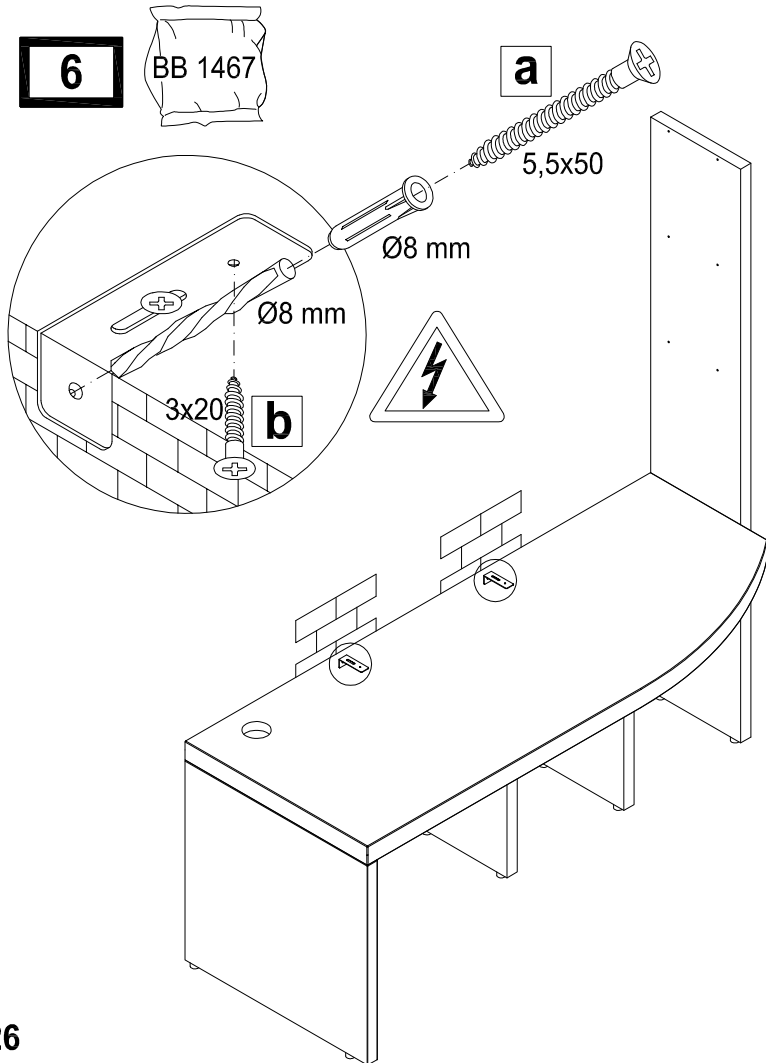

7

BB 1468

4x17

4x17

100mm

90°

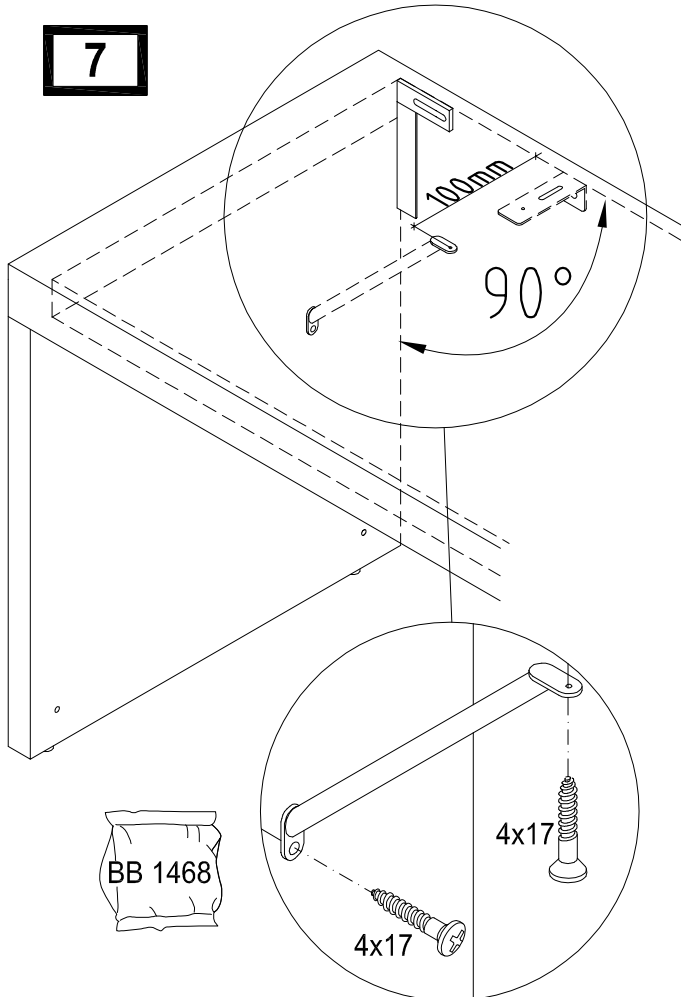

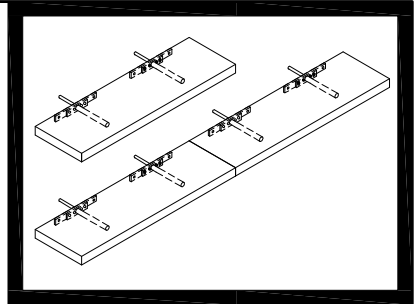
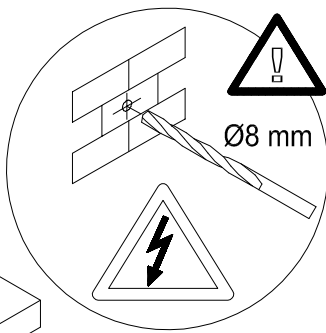
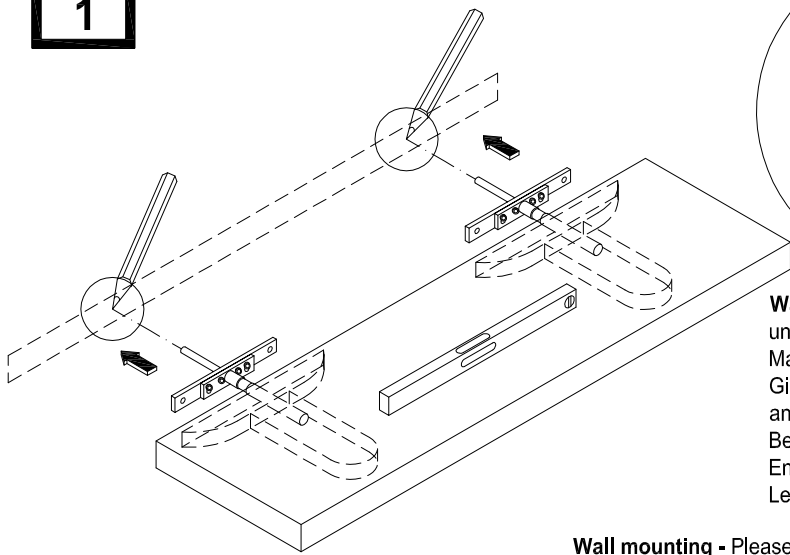
1

Wandbefestigung - Achtung! Die Wandbeschaffenheit ist vor der Montage unbedingt zu prüfen. Verwendung von Dübeln bei Beton und/oder festem Mauerwerk. Bei abweichender Beschaffenheit (z.B. Rahmenbauweise mit Gipskartonplatten, Leichtbausteinen etc.) ist eine andere, der Belastung angemessene Befestigung bauseits vorzunehmen. Beachten Sie, dass in dem Befestigungsbereich keine Elektro-Installationszonen und keine Ver- oder Entsorgungsleitungen vorhanden sein dürfen. Prüfen Sie mit einem geeigneten Leitungssuchgerät. Beachten Sie, dass Kunststoffrohre nicht dedektiert werden.

Wall mounting - Please note! Please be sure to test the soundness of walls beforehand. Use plugs for concrete and solid walls. Use a different method that is capable of withstanding the load for lighter types of walls (e.g. framed gypsum plaster board, light brickwork, etc.). Please note that there must not be any electrical installations nor any electrical connections or leads of any kind in the assembly area. Please ensure this is so by testing the area with a suitable electrical leads search device. Please also note that plastic tubing will not be detected.

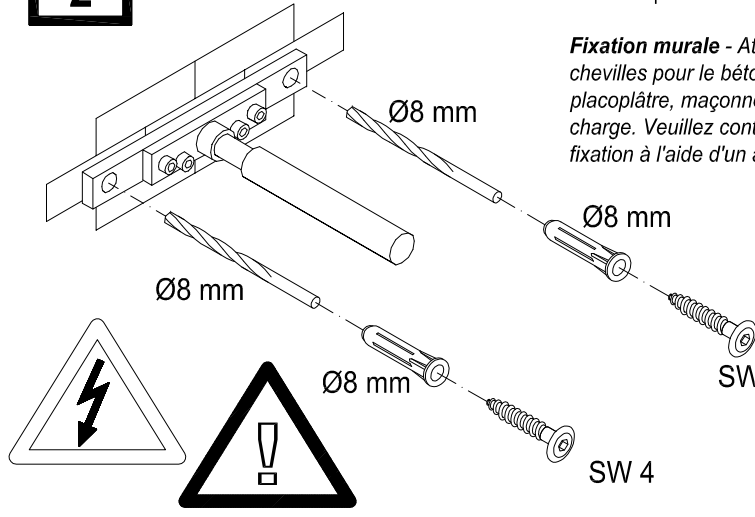
2

Fixation murale - Attention! La composition du mur doit absolument être contrôlée. Utilisation de chevilles pour le béton et/ou la maçonnerie dure. Pour les autres types de construction (cloisons en placoplâtre, maçonnerie légère, etc...), il faut prévoir un autre mode de fixation en rapport avec la charge. Veuillez contrôler l'absence d'installations électriques et de conduits dans le secteur de la fixation à l'aide d'un appareil. Veuillez noter que les tubes en matière synthétique ne sont pas détectés.

Bevestiging aan de muur - Attentie! Controleer, alvorens te beginnen, altijd de aard en de kwaliteit van de muur, waaraan gemonteerd moet worden. Gebruik voor de bevestiging aan beton en schoon metselwerk de door hülsta meegeleverde standaard pluggen en passende schroeven. In geval van muren van een ander, lichter soort materiaal (bijv. gipsplaten op een raamwerk of lichte bouwstenen) moet een ander, aan het draagvermogen aangepast speciaal bevestigingsmateriaal gebruikt worden. N.B.! In het muurgedeelte waar gemonteerd moet worden, mogen zich geen elektro-installatiezones bevinden resp. mogen geen aan- en/of afvoerleidingen (buizen) lopen. Dit kan gecontroleerd worden met speciale daarvoor bestemde detectieapparatuur. N.B.! Kunststofleidingen kunnen helaas niet worden gedetecteerd.

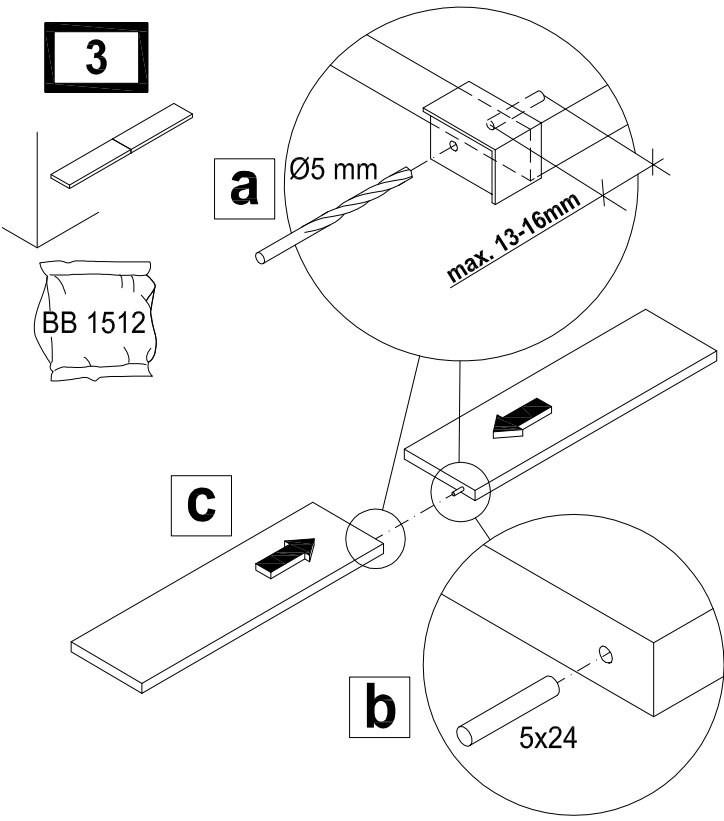
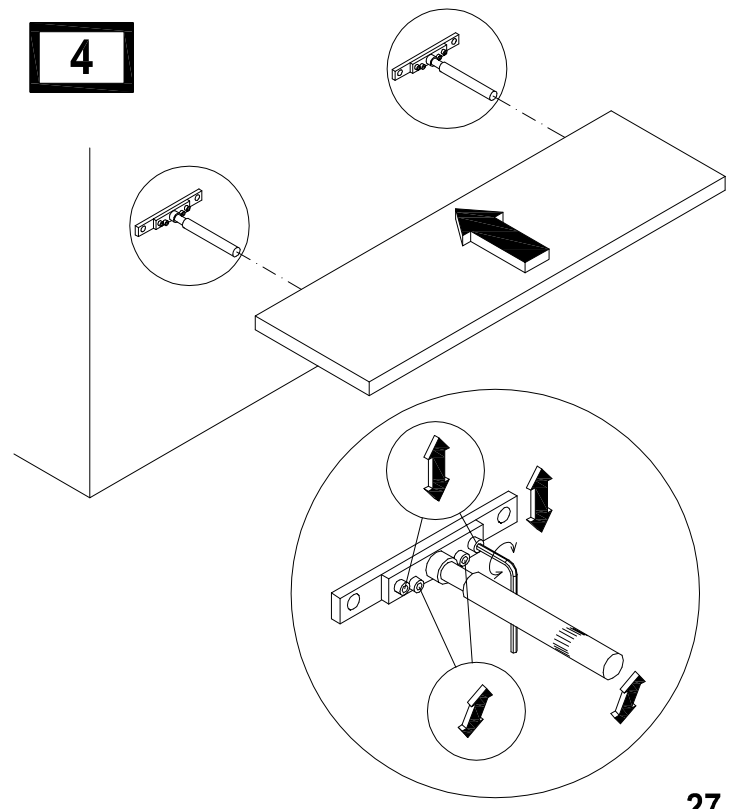



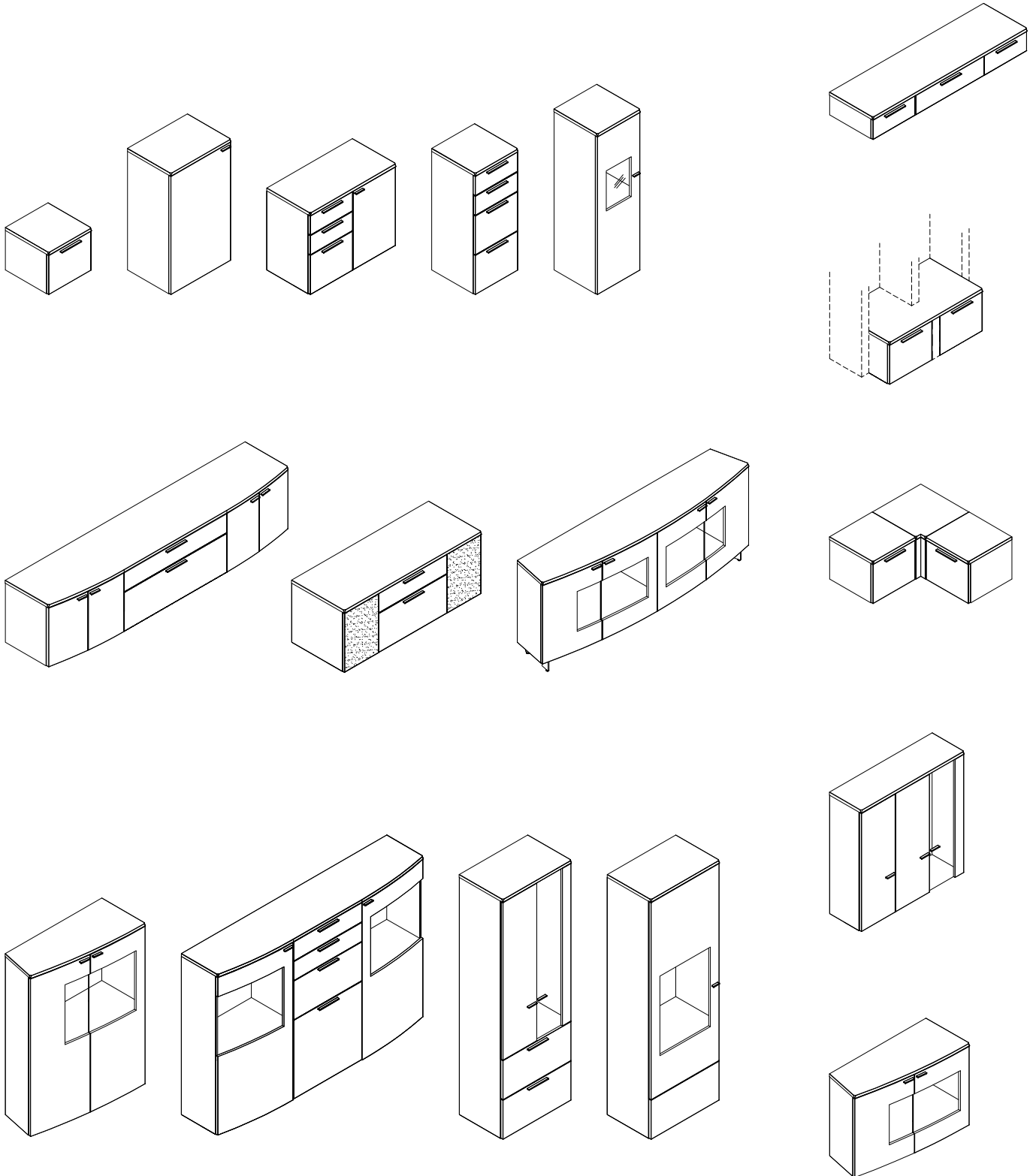



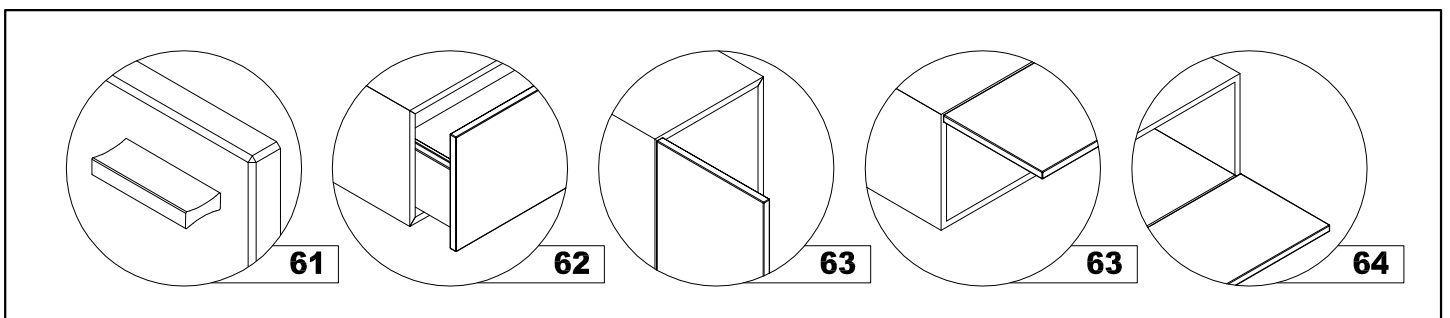
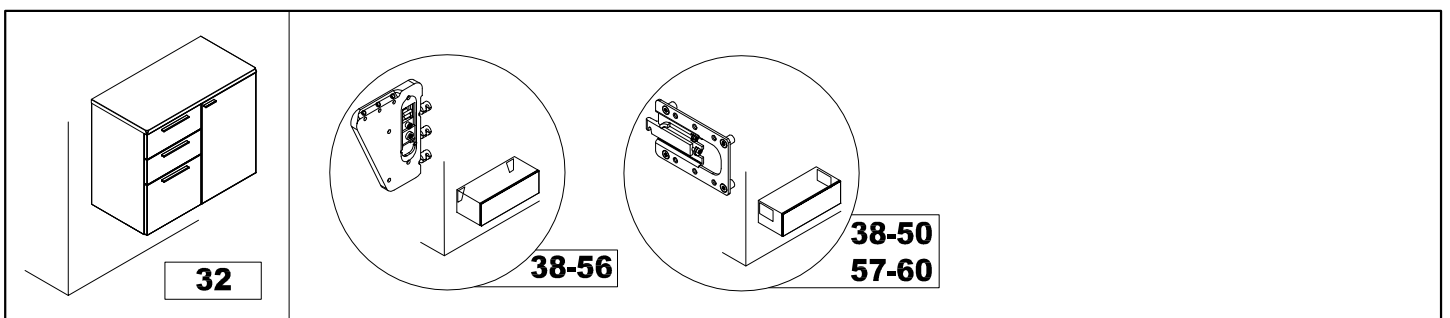
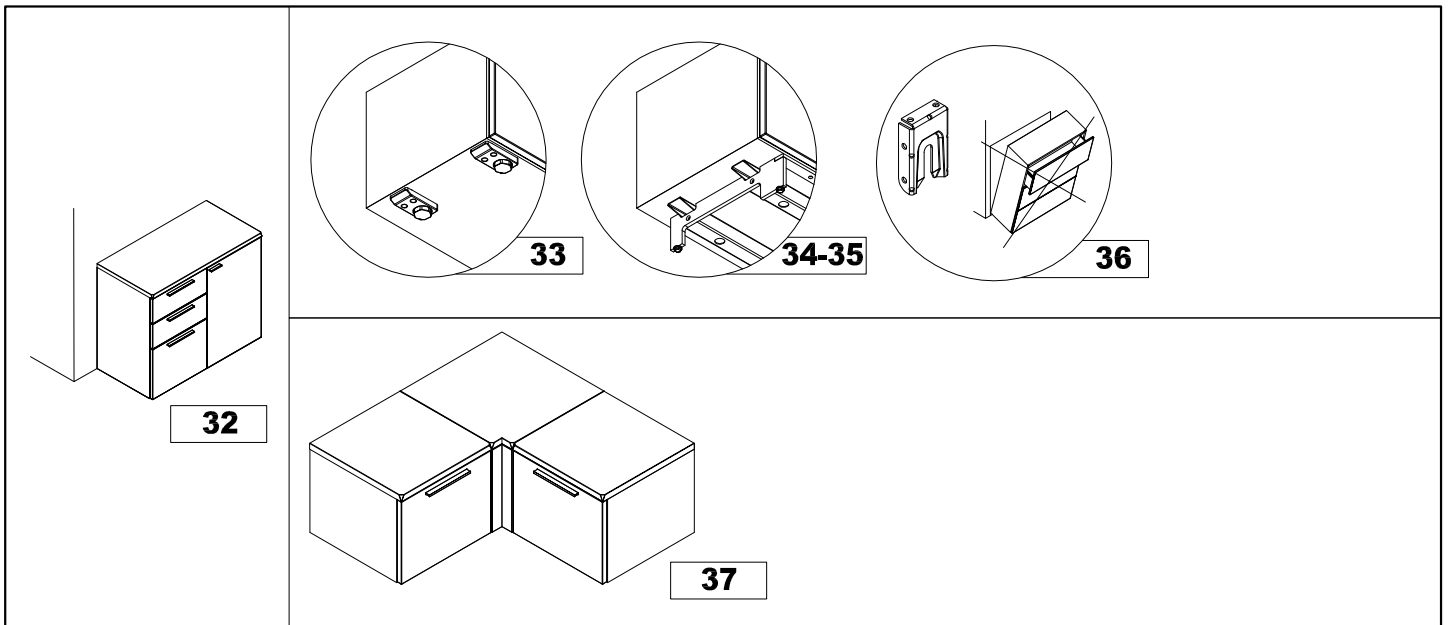
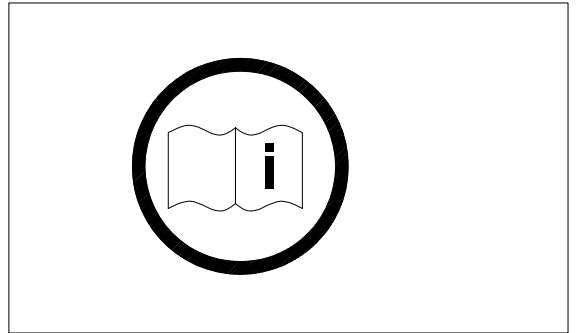
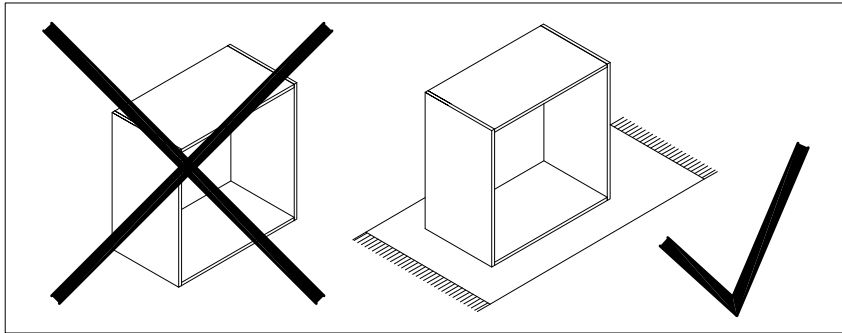
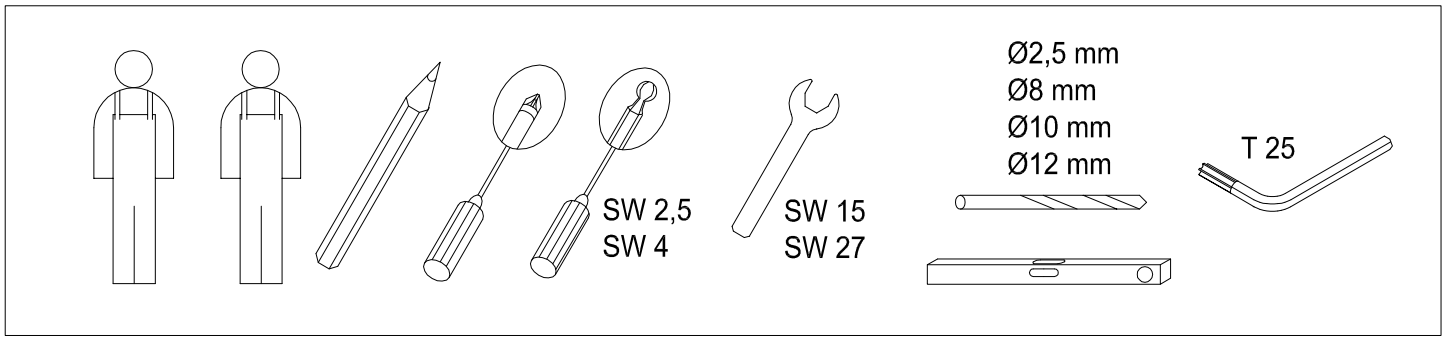

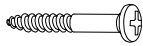
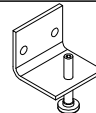
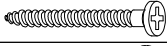
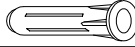
3**4**

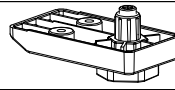
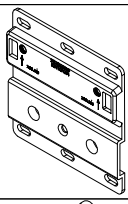



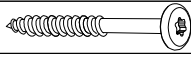

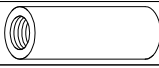
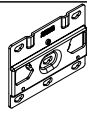

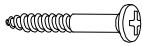
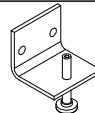
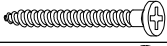
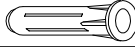

NURIA

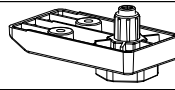
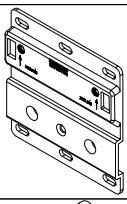



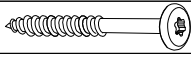

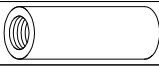







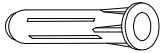

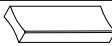
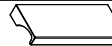

hülsta 



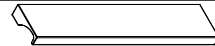

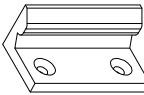
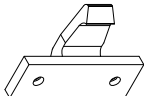



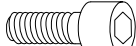
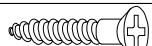
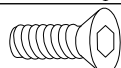



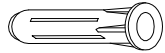



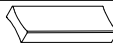



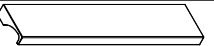

BB 1466		Mat. 1156136	
12x		4x35	
BB 1920		Mat. 1374227	
1x			
2x		5,5X60	
2x		Ø8 mm	
BB 2034		Mat. 1434137	
8x		4x17	
4x			
BB 2072/2073		Mat. 1443277/1443278	
2x/1x			
2x/1x		M6x8	
BB 2445		Mat. 1577443	
12x		4,5x35	
12x			
BB 2460		Mat. 1535746	
4x		Ø8 mm	
4x		6x70	
BB 2470		Mat. 1595404	
12x		M4x15	
10x		M4x30	
BB 2509/2510		Mat. 1601505/1601506	
2x/1x			
BB 2511		Mat. 1601507	
2x			

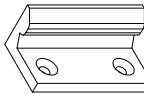
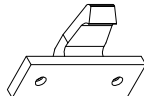
BB 1466		Mat. 1156136	
12x		4x35	
BB 1920		Mat. 1374227	
1x			
2x		5,5X60	
2x		Ø8 mm	
BB 2034		Mat. 1434137	
8x		4x17	
4x			
BB 2072/2073		Mat. 1443277/1443278	
2x/1x			
2x/1x		M6x8	
BB 2445		Mat. 1577443	
12x		4,5x35	
12x			
BB 2460		Mat. 1535746	
4x		Ø8 mm	
4x		6x70	
BB 2470		Mat. 1595404	
12x		M4x15	
10x		M4x30	
BB 2509/2510		Mat. 1601505/1601506	
2x/1x			
BB 2511		Mat. 1601507	
2x			

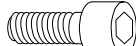

BB 2543		Mat. 1609305	
2x			
BB 2584		Mat. 1617943	
2x		6,3x90	
2x		Ø10 mm	
BB 2615 / 2618 / 2621 / 2624 Mat. 1643110 / 1643113 / 1643116 / 1643119			
1x			
2x		4x28	
BB 2616 / 2619 / 2622 / 2625 Mat. 1643111 / 1643114 / 1643117 / 1643120			
1x			
2x		4x28	
2x		4x13	
2x			
BB 2617 / 2620 / 2623 / 2626 Mat. 1643112 / 1643115 / 1643118 / 1643121			
1x			
2x		4x28	
BB 2628		Mat. 1643281	
4x			
4x			
16x		3,5x17	
4x		4 mm	
BB 2639/2640 Mat. 1649297/1649298			
4x/4x		M4x20	
4x/8x		M5x12	
12x/4x		4,5x20	
2x/4x		M6x16	

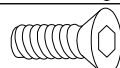
BB 2543		Mat. 1609305	
2x			
BB 2584		Mat. 1617943	
2x		6,3x90	
2x		Ø10 mm	
BB 2615 / 2618 / 2621 / 2624 Mat. 1643110 / 1643113 / 1643116 / 1643119			
1x			
2x		4x28	
BB 2616 / 2619 / 2622 / 2625 Mat. 1643111 / 1643114 / 1643117 / 1643120			
1x			
2x		4x28	
2x		4x13	
2x			
BB 2617 / 2620 / 2623 / 2626 Mat. 1643112 / 1643115 / 1643118 / 1643121			
1x			
2x		4x28	
BB 2628		Mat. 1643281	
4x			
4x			
16x		3,5x17	
4x		4 mm	
BB 2639/2640 Mat. 1649297/1649298			
4x/4x		M4x20	
4x/8x		M5x12	
12x/4x		4,5x20	
2x/4x		M6x16	



1

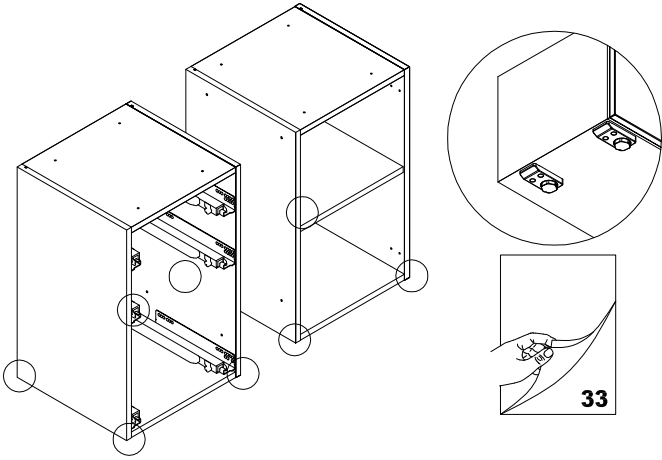
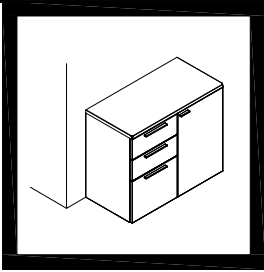

1

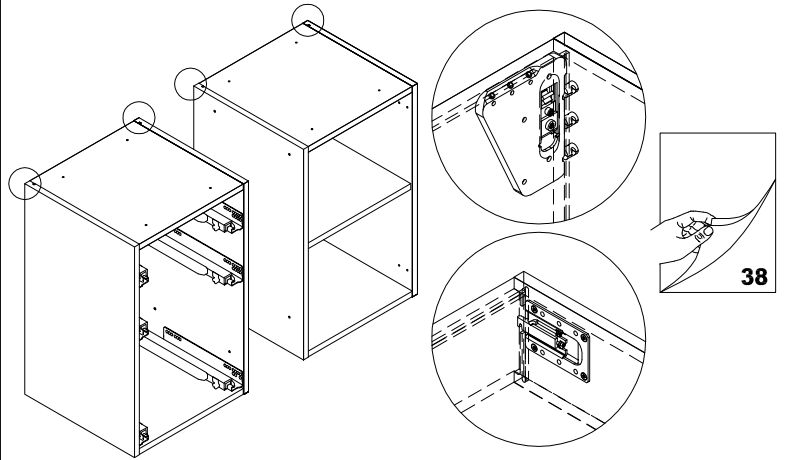
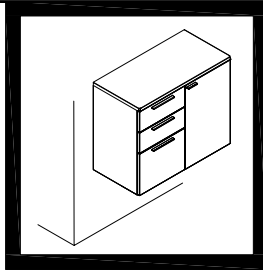

2

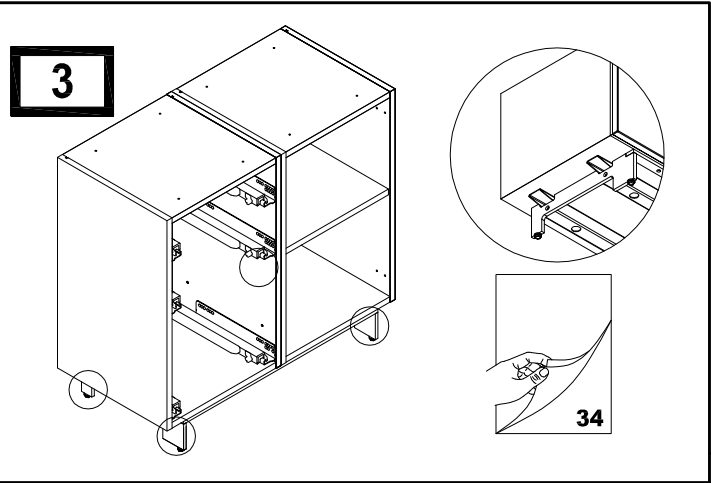

2

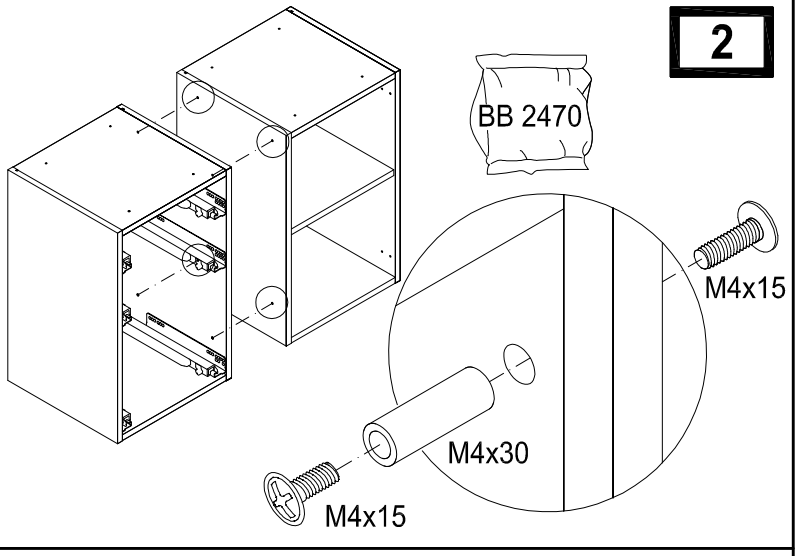

4

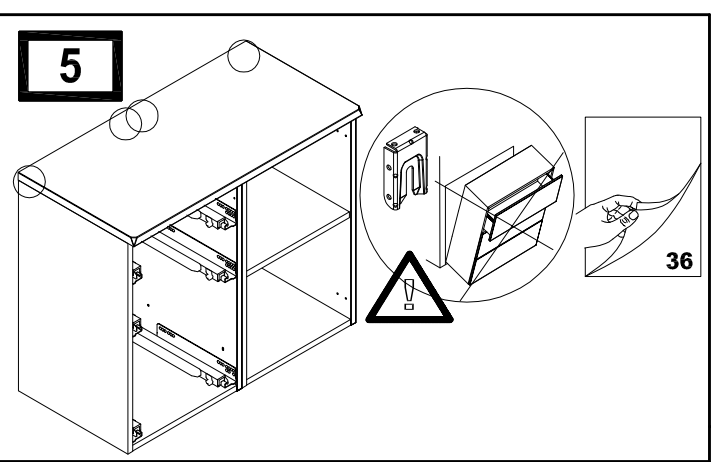

3

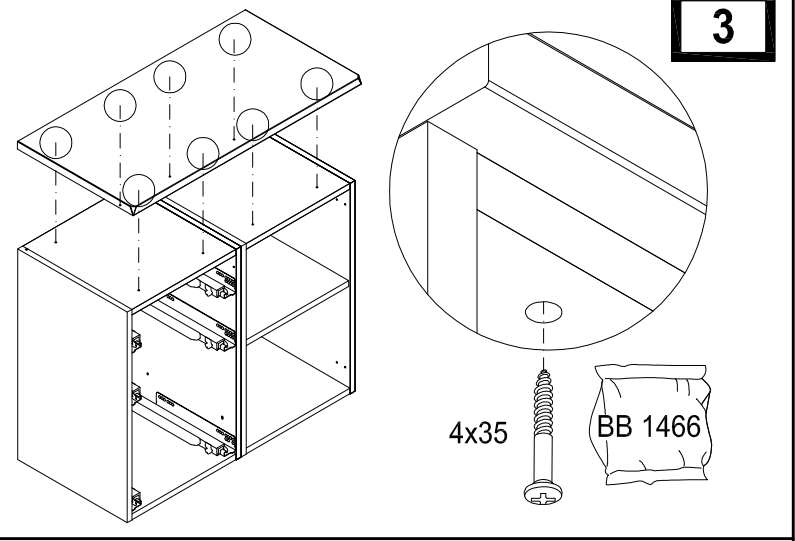

6

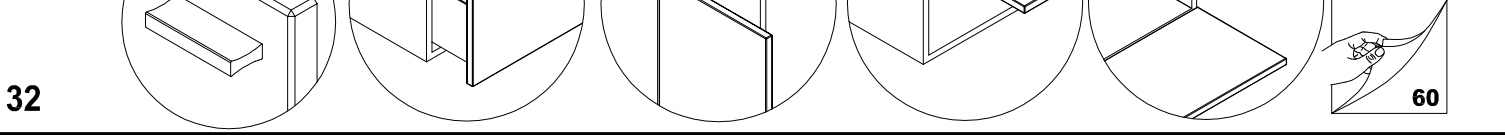

4

32

60

1

BB 2034

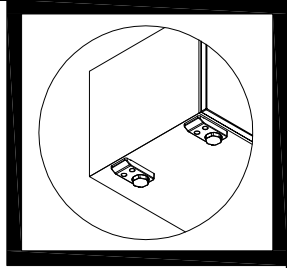
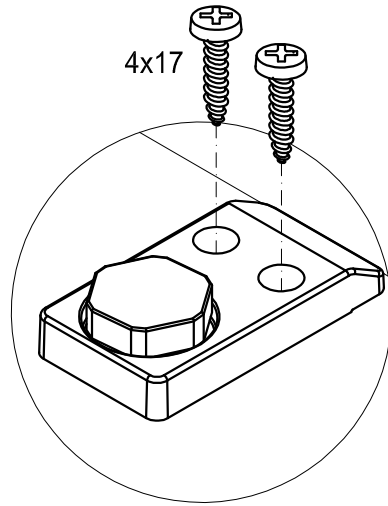
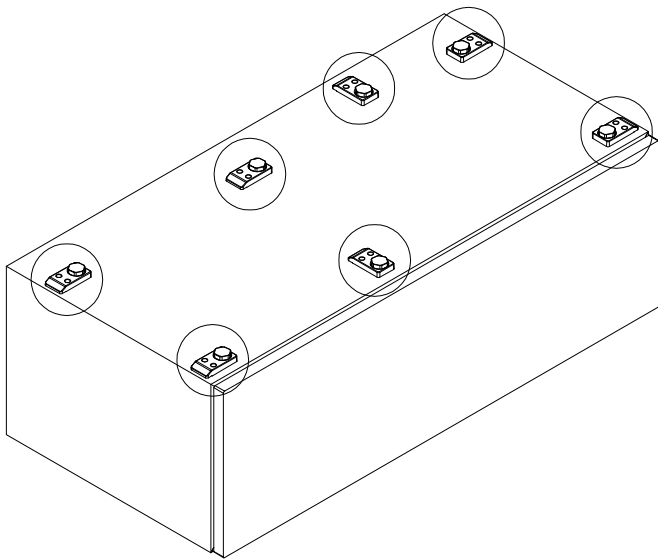

2

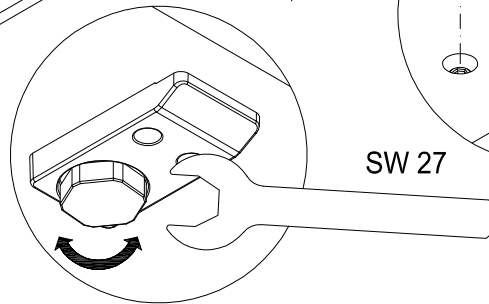
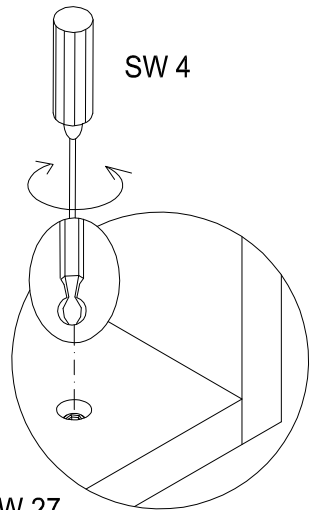
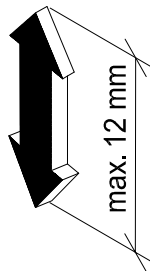
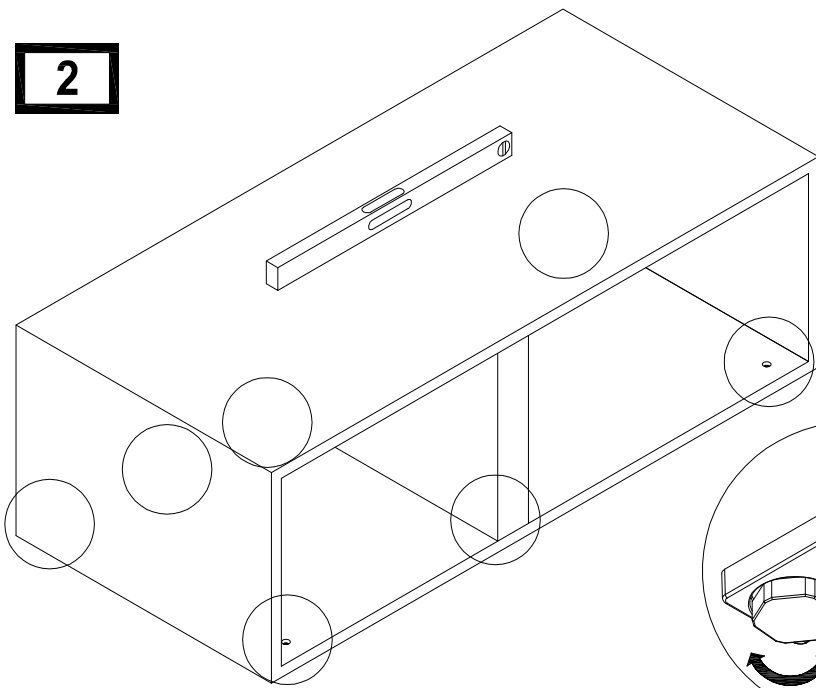

2

BB 2470

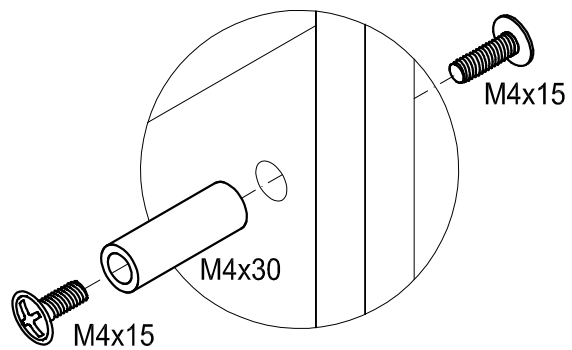
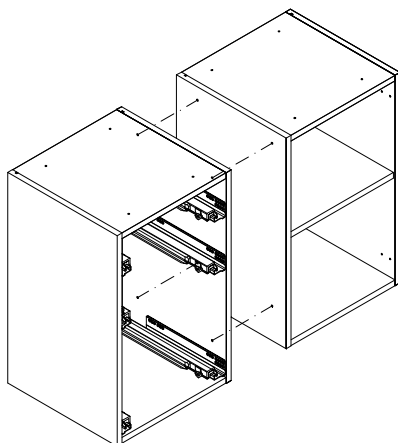

1

BB 2639
BB 2640

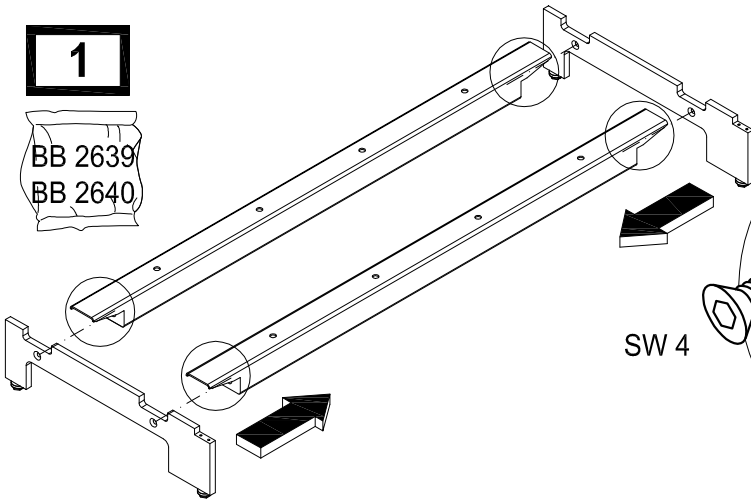

SW 4

M6x16

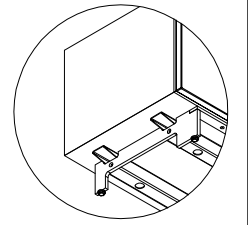
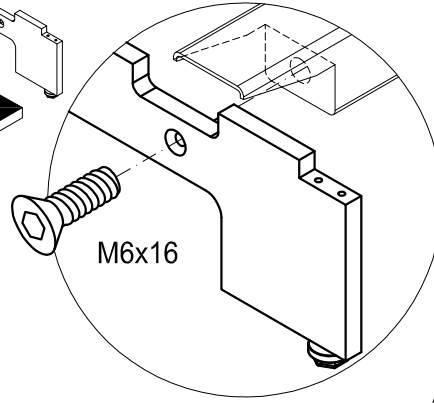

BB 2639

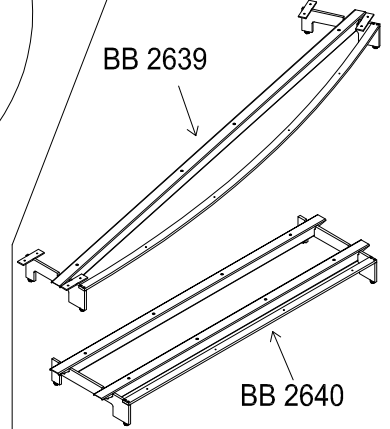

BB 2640

2

BB 2639
BB 2640

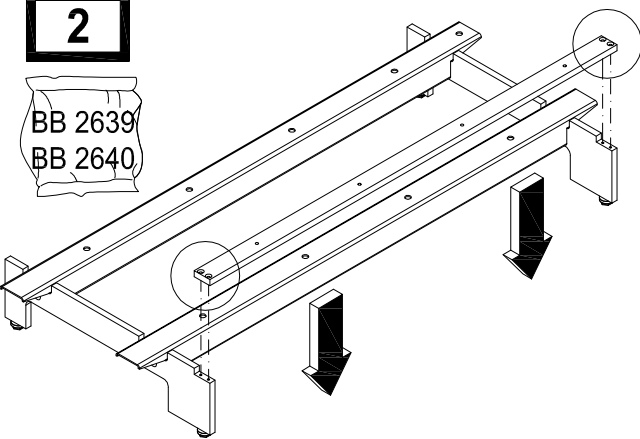

SW 2,5

M4x20

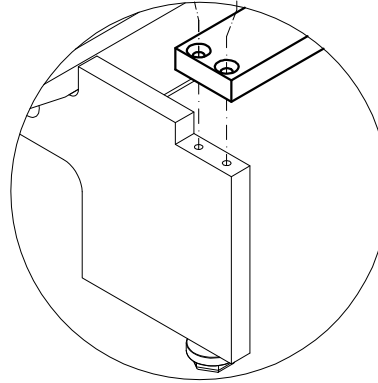

3

BB 2639
BB 2640

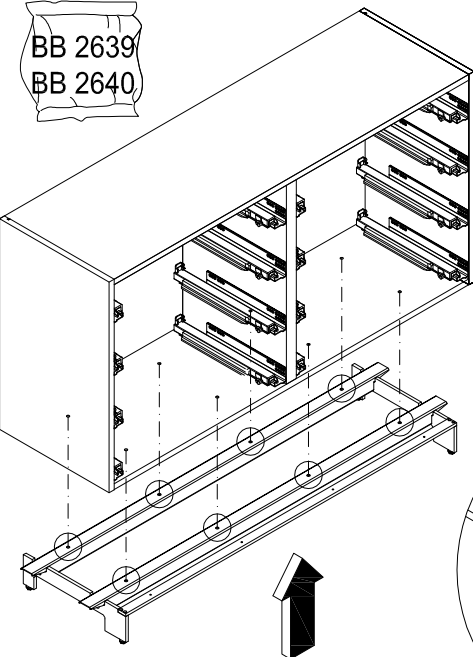

M5x12

SW 4

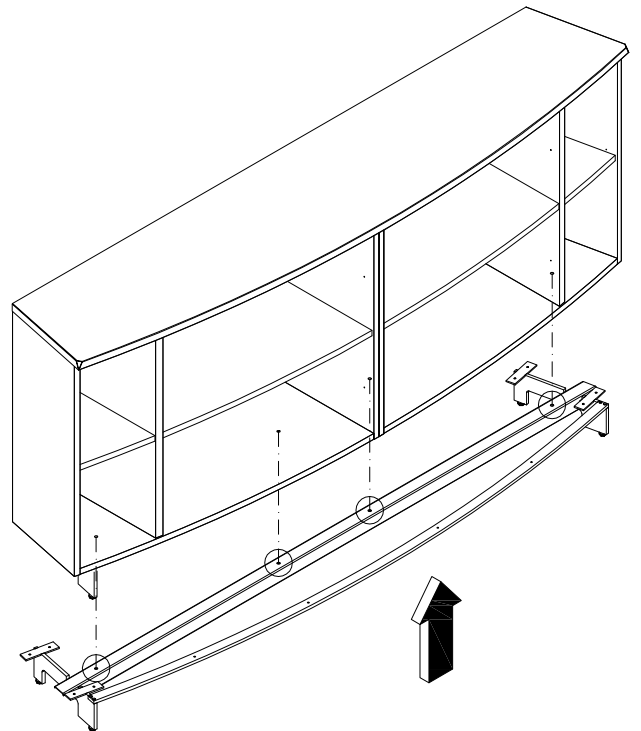
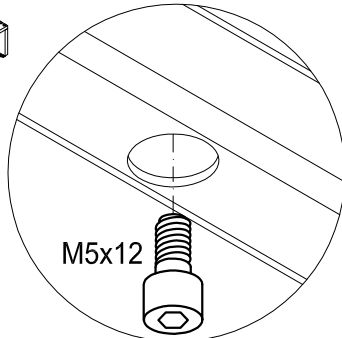

4

BB 2639
BB 2640

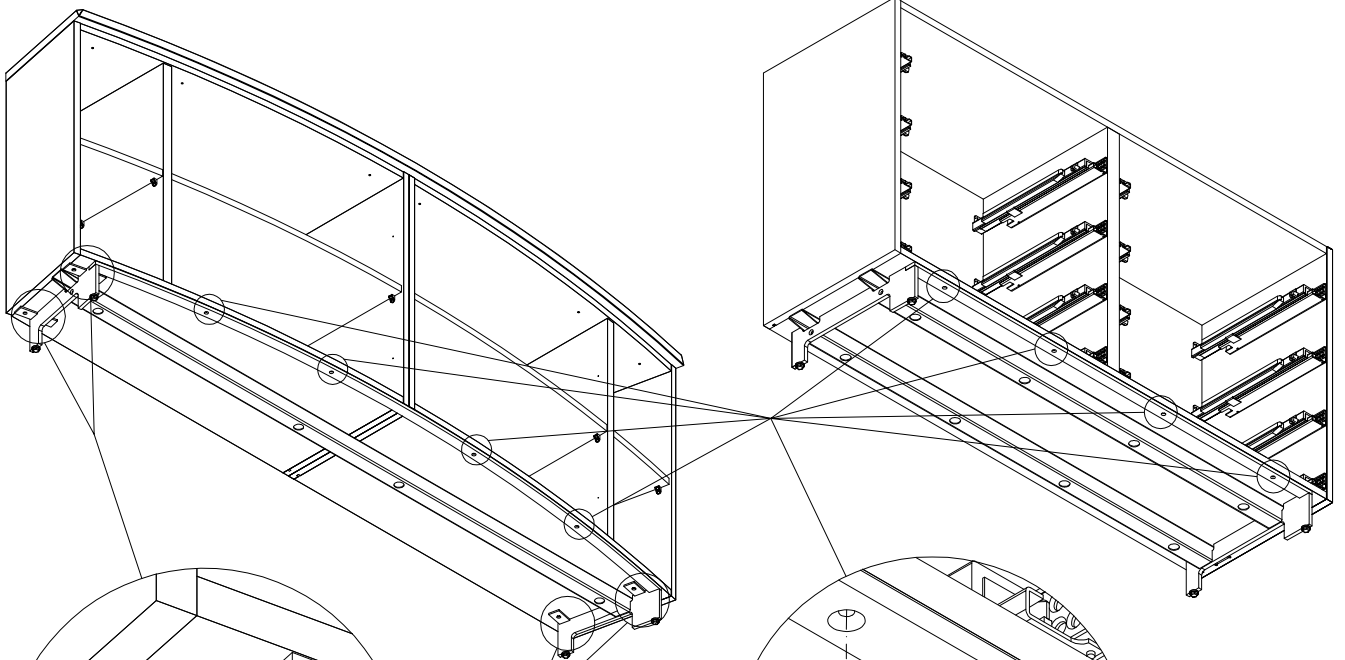

a

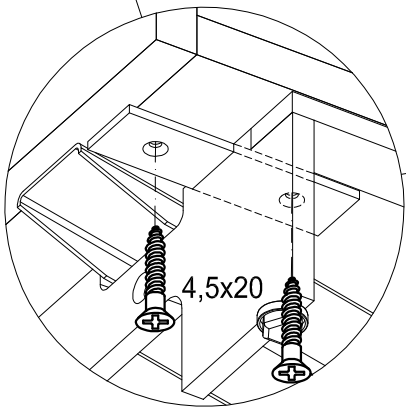

b

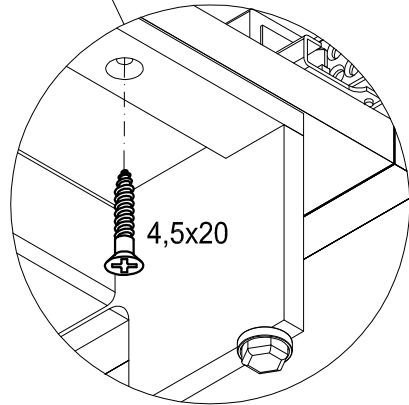

5

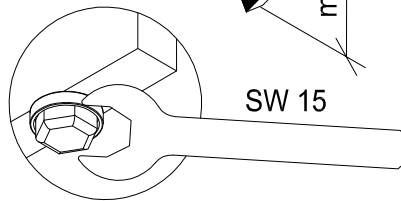
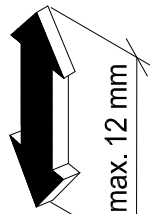
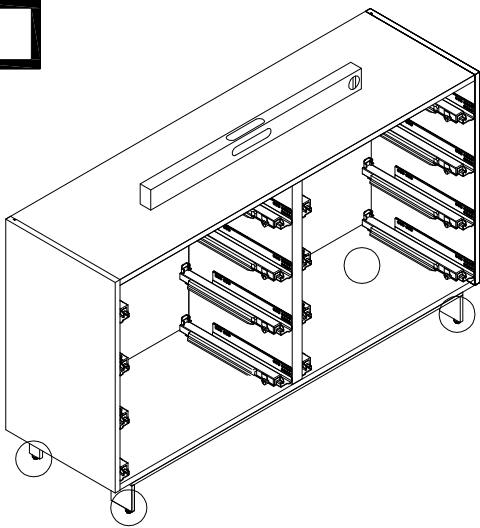

4

BB 1466

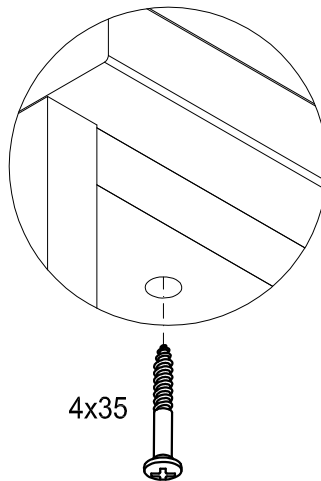
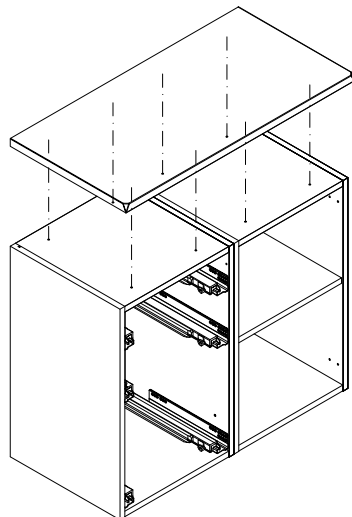

1

BB 2584

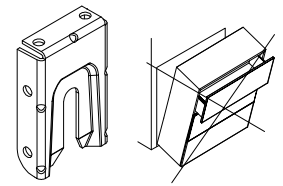
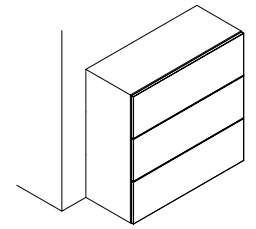
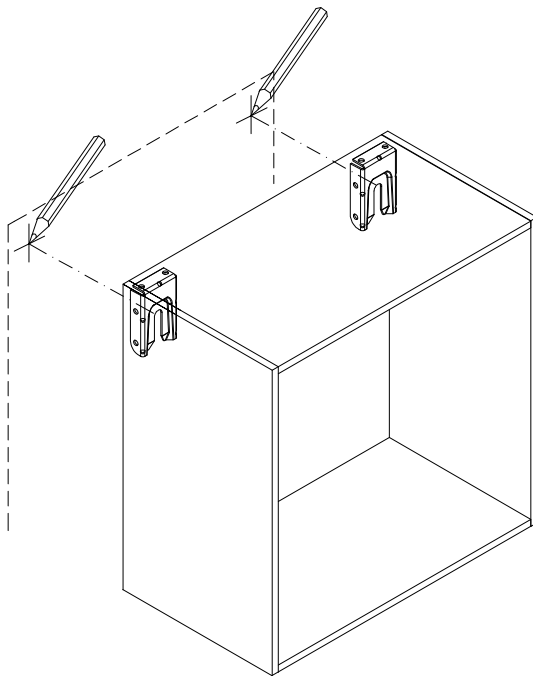
**2**

BB 2584

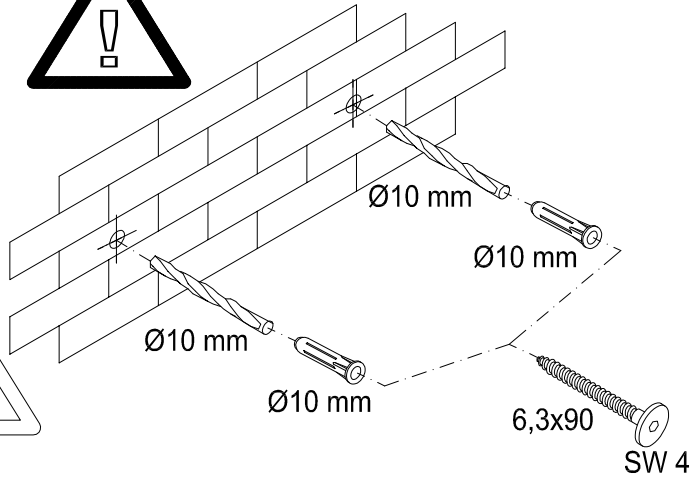
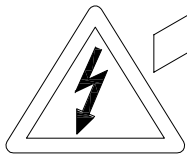
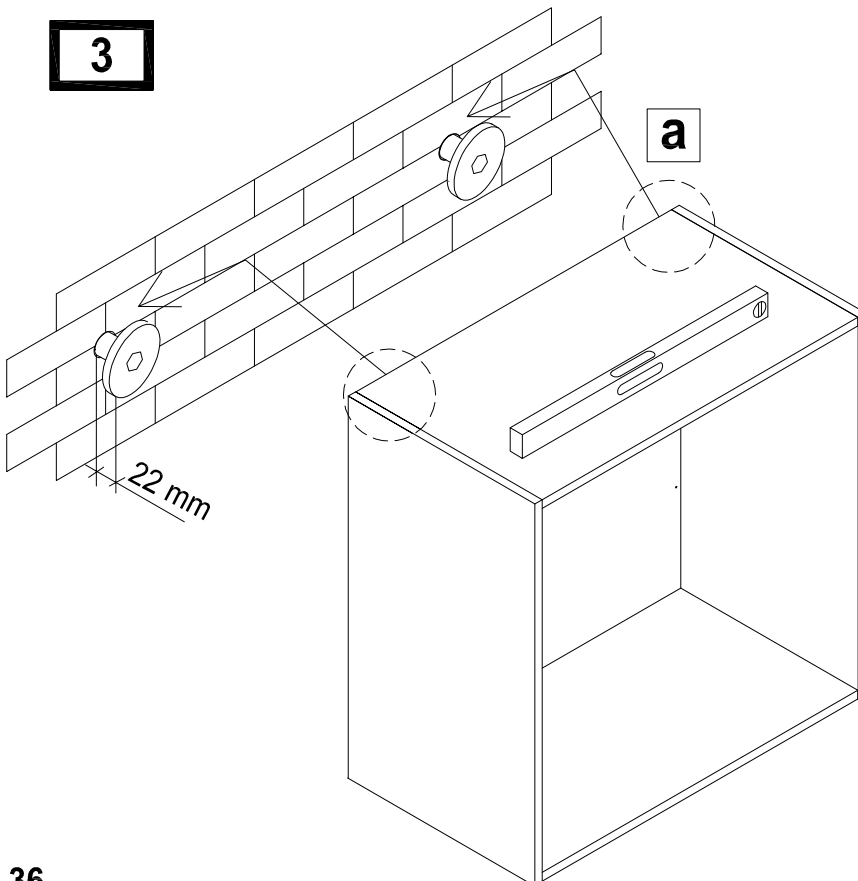
**3****Kippsicherung**

Achtung! Die Wandbeschaffenheit ist vor der Montage unbedingt zu prüfen. Verwendung von Dübeln bei Beton und/oder festem Mauerwerk. Bei abweichender Beschaffenheit (z.B. Rahmenbauweise mit Gipskartonplatten, Leichtbausteinen etc.) ist eine andere, der Belastung angemessene Befestigung bauseits vorzunehmen. Beachten Sie, dass In dem Befestigungsbereich keine Elektro-Installationszonen und keine Ver- oder Entsorgungsleitungen vorhanden sein dürfen. Prüfen Sie mit einem geeigneten Leitungssuchgerät. Beachten Sie, dass Kunststoffrohre nicht dedektiert werden.

Anti-tilt device

Please note! Please be sure to test the soundness of walls beforehand. Use plugs for concrete and solid walls. Use a different method that is capable of withstanding the load for lighter types of walls (e.g. framed gypsum plaster board, light brickwork, etc.). Please note that there must not be any electrical installations nor any electrical connections or leads of any kind in the assembly area. Please ensure this is so by testing the area with a suitable electrical leads search device. Please also note that plastic tubing will not be detected.

Protection contre le basculement

Attention! La composition du mur doit absolument être contrôlée. Utilisation de chevilles pour le béton et/ou la maçonnerie dure. Pour les autres types de construction (cloisons en placoplâtre, maçonnerie légère, etc...), il faut prévoir un autre mode de fixation en rapport avec la charge. Veuillez contrôler l'absence d'installations électriques et de conduits dans le secteur de la fixation à l'aide d'un appareil. Veuillez noter que les tubes en matière synthétiques ne sont pas détectés.

Omkiepbeveiliging

Attentie! Controleer, alvorens te beginnen, altijd de aard en de kwaliteit van de muur, waaraan gemonteerd moet worden. Gebruik voor de bevestiging aan beton en schoon metselwerk de door hülsta meegeleverde standaard pluggen en passende schroeven. In geval van muren van een ander, lichter soort materiaal (bijv. gipsplaten op een raamwerk of lichte bouwstenen) moet een ander, aan het draagvermogen aangepast speciaal bevestigingsmateriaal gebruikt worden. N.B.! In het muurgedeelte waar gemonteerd moet worden, mogen zich geen elektro-installatiezones bevinden resp. mogen geen aan- en/of afvoersleidingen (buizen) lopen. Dit kan gecontroleerd worden met speciale daarvoor bestemde detectieapparatuur. N.B.! Kunststofleidingen kunnen helaas niet worden gedetecteerd.

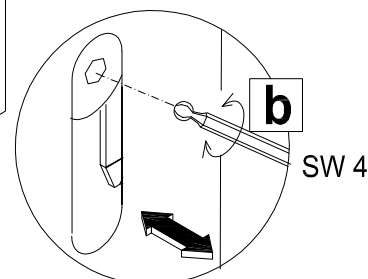

1

BB 2628

a

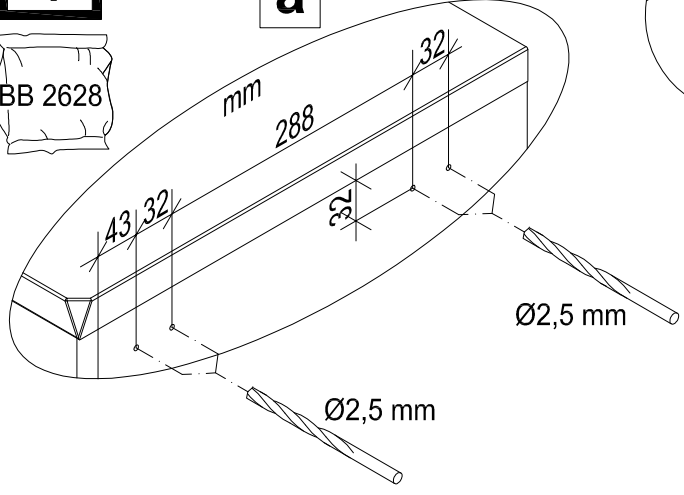

b

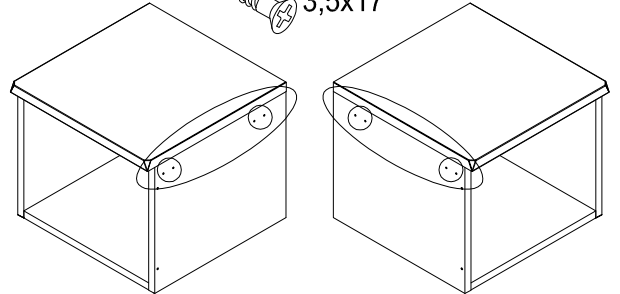
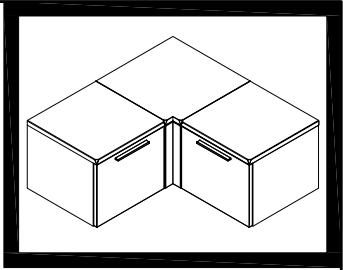
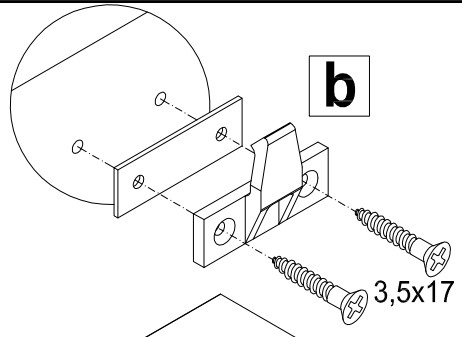

2

BB 1920

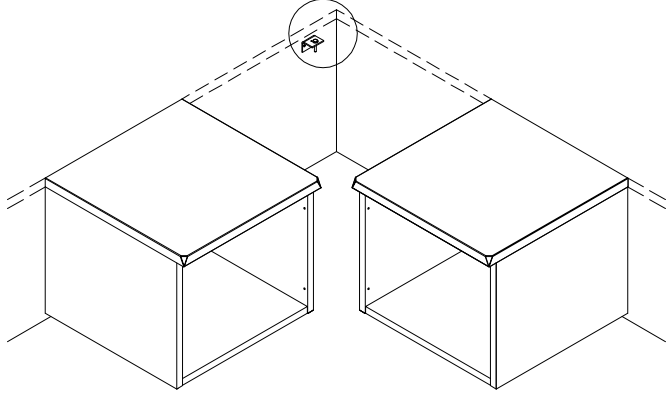
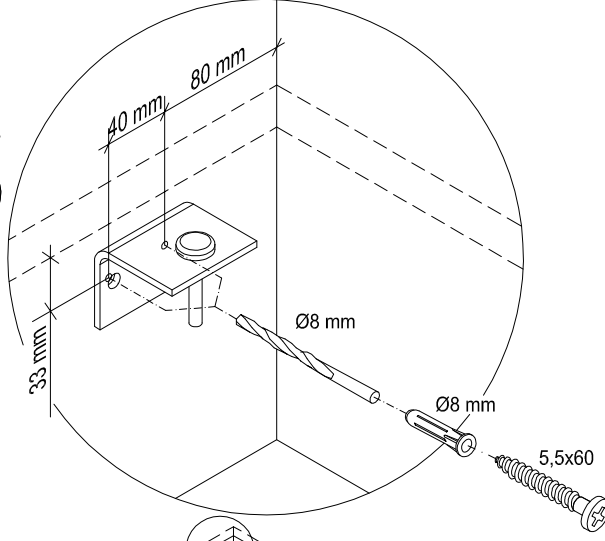

3

BB 2445

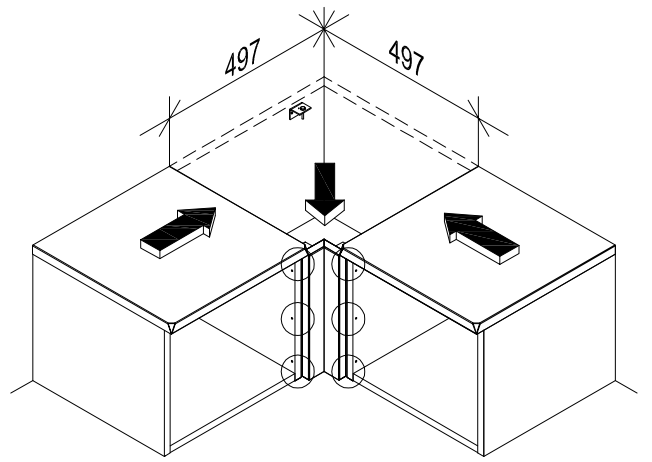
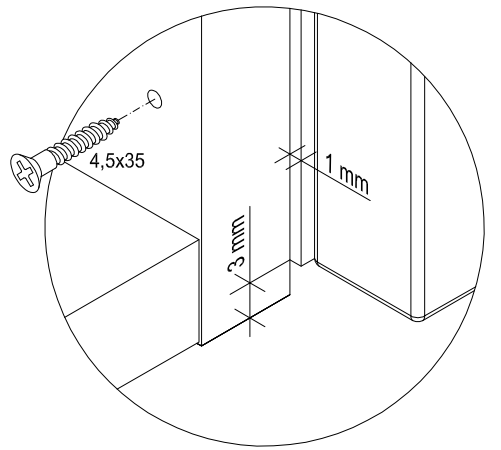

3

BB 2628

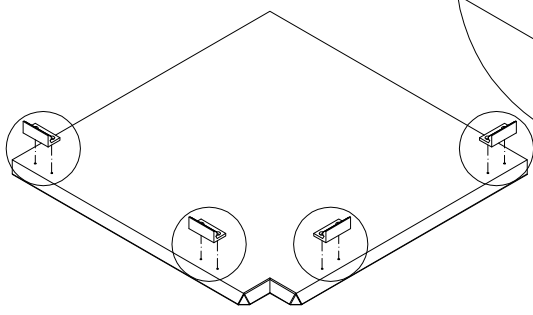
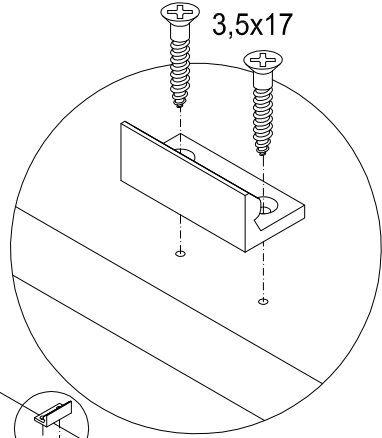

4

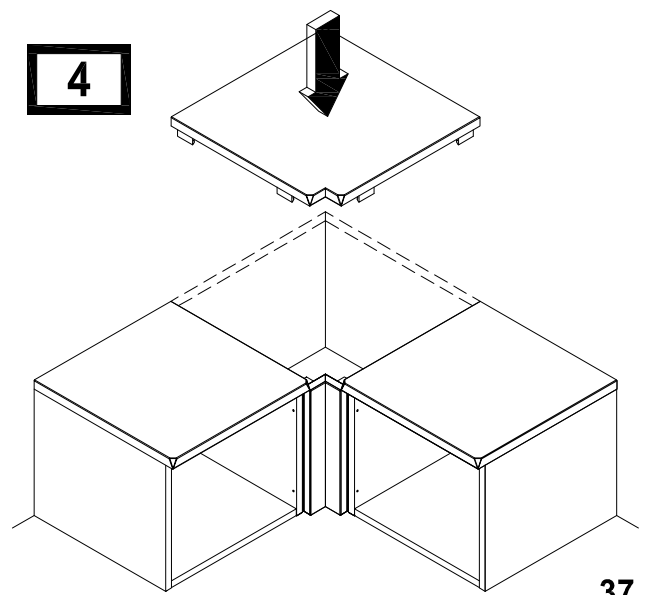

1



Benötigte Wandbeschaffenheit
Required structure of wall
Caracteristiques indispensables pour la composition du mur
Vereiste wandstructuur

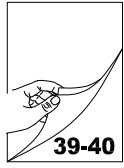

Deutsch

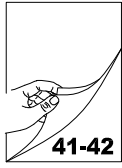

English



Français

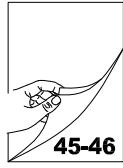

Nederlands

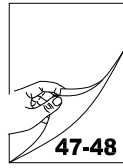

Русский

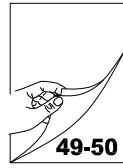

中文

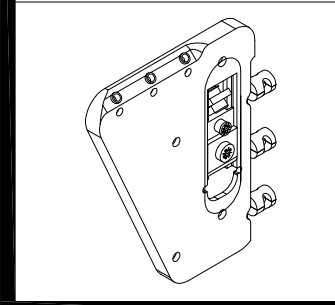
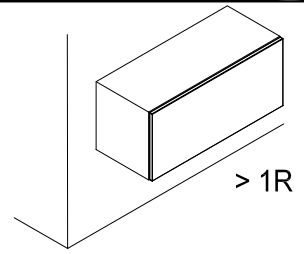
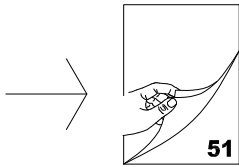

1



Benötigte Wandbeschaffenheit
Required structure of wall
Caracteristiques indispensables pour la composition du mur
Vereiste wandstructuur

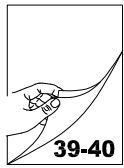

Deutsch

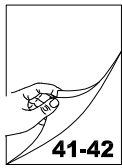

English



Français

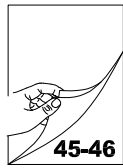

Nederlands



Русский

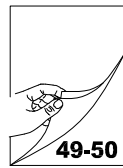

中文

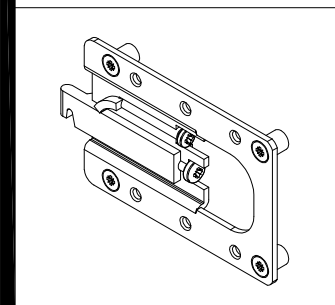
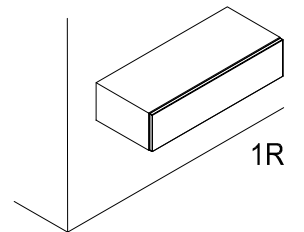
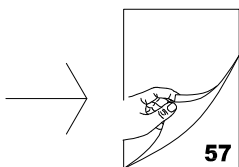

D: BENÖTIGTE WANDBESCHAFFENHEIT

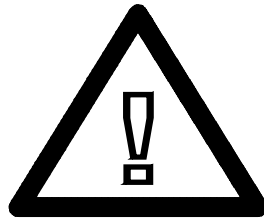

Achtung! Die Wandbeschaffenheit ist vor der Montage sorgfältig durch einen **Fachmann** zu überprüfen. Die Montage darf nur durch einen **Fachmann** unter sorgfältiger Beachtung der Montagehinweise erfolgen. Die in dem Standard Set Mat. Nr. 1535746 beigefügten Fischer Kunststoff Dübel SX 8x65 sind nur geeignet, wenn die Wandbeschaffenheiten und Druckfestigkeiten gem. der u.a. Tabelle vorliegen. Eine Montage an Leichtbauwänden ist ausgeschlossen. In allen anderen Fällen ist zwingend eine andere geeignete Befestigungsart durch einen **Fachmann** auszuwählen. Für die sachgerechte Auswahl der anderen Befestigungsart übernimmt hülsta keine Haftung. Bitte beachten Sie, dass bei unsachgemäßer Befestigung der Möbel an der Wand ein Risiko des Herabfallens bzw. Umkippens besteht – besonders bei Verwendung von bauseitig beschafften alternativen Befestigungsmaterialien. Generell sind Sie als Händler/Fachmonteur für die fachgerechte Wandbefestigung verantwortlich. Bei der Montage ist ferner darauf zu achten, dass in dem Befestigungsbereich keine Elektro-Installationszonen und keine Ver- und Entsorgungsleitungen vorhanden sein dürfen. Dies ist mit einem geeigneten Leitungssuchgerät zu prüfen. Zu beachten ist, dass Kunststoffrohre nicht detektiert werden.

Standard Set Mat. Nr. 1535746

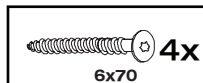
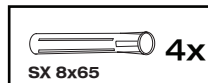

Das Standard Set Mat. Nr. 1535746 ist ausschließlich geeignet für die nachfolgenden Wandbeschaffenheiten. Dabei dürfen die aufgeführten Druckfestigkeitswerte in keinem Fall unterschritten werden.

Beton



Beton

C12/15

Druckfestigkeit
>= 15 N/mm²

Empfohlene Bohrrart:

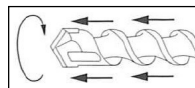

Hammerbohren: Bohren mit Bohrhammer (harte Schläge, großer Bohrfortschritt) für Bohrungen, an die eine hohe Bohrqualität gestellt wird. Geeignet an Untergründe aus Vollstein mit dichtem Gefüge (Beton etc.). Bohrlöcher sind nach dem Bohren durch Ausblasen oder Aussaugen gründlich von Bohrrückständen zu reinigen.

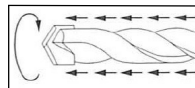

Schlagbohren: Bohren mit Schlagbohrmaschine (leichte Schläge) für Untergründe aus Mauerwerk mit dichtem Gefüge (z.B. Vollziegel, Kalksandvollstein). Bohrlöcher sind nach dem Bohren durch Ausblasen oder Aussaugen gründlich von Bohrrückständen zu reinigen.

Hinweis:

Bei der Bohrlöcherherstellung keine abgenutzten Bohrer verwenden, da sonst das Eindrehmoment der Schraube zu hoch wird und somit sich die Schraube schwer eindrehen lässt.

Das Set kann eingesetzt werden für Wände bis max. 15 mm Putz oder anderen nichttragenden Schichten. Wird dieses Maß überschritten, müssen unter Umständen andere Befestigungssysteme gewählt werden.

Achtung ! Die Wandbeschaffenheit ist vor der Montage sorgfältig durch einen **Fachmann** zu überprüfen. Die Montage darf nur durch einen **Fachmann** unter sorgfältiger Beachtung der Montagehinweise erfolgen. Das Set Montagemörtel Mat. Nr. 1535747 muss verwendet werden, wenn die Wandbeschaffenheiten und Druckfestigkeiten gem. der u.a. Tabelle vorliegen. Eine Montage an Leichtbauwänden ist ausgeschlossen. In allen anderen Fällen ist zwingend eine andere geeignete Befestigungsart durch einen **Fachmann** auszuwählen. Für die sachgerechte Auswahl der anderen Befestigungsart übernimmt hülsta keine Haftung. Bitte beachten Sie, dass bei unsachgemäßer Befestigung der Möbel an der Wand ein Risiko des Herabfallens bzw. Umkippens besteht – besonders bei Verwendung von bauseitig beschafften alternativen Befestigungsmaterialien. Generell sind Sie als Händler/Fachmonteur für die fachgerechte Wandbefestigung verantwortlich. Bei der Montage ist ferner darauf zu achten, dass in dem Befestigungsbereich keine Elektro-Installationszonen und keine Ver- und Entsorgungsleitungen vorhanden sein dürfen. Dies ist mit einem geeigneten Leitungssuchgerät zu prüfen. Zu beachten ist, dass Kunststoffrohre nicht detektiert werden.

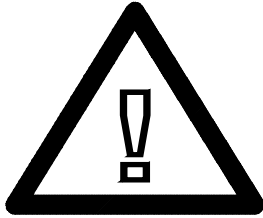

Set Montagemörtel Mat. Nr. 1535747
(ausreichend f. 9 Verankerungen)

 FIS H12 x 85 K 9x	 Statikmischer 2x	 1x
 FIS E 6x75 K 9x		

Das Wandbefestigungsset ist ausschließlich geeignet für die nachfolgenden Wandbeschaffenheiten. Dabei dürfen die aufgeführten Druckfestigkeitswerte in keinem Fall unterschritten werden.

Montage mit Ankerhülse FIS H12 x 85 K

Lochbaustoffe					Empfohlene Bohrart:
	Hochlochziegel	HLz≥12	Druckfestigkeit ≥/ = 12 N/mm ² Rohdichte ≥/ = 1 kg/dm ³		 Drehbohren: Mit normaler Bohrmaschine <u>ohne Schlag</u> in Lochstein (damit die Baustoffstege nicht ausbrechen und das Bohrloch nicht zu groß wird). Bohrlöcher sind nach dem Bohren durch Ausblasen oder Aussaugen gründlich von Bohrrückständen zu reinigen. Hinweis: Das Set kann eingesetzt werden für Wände bis <u>max. 15 mm</u> Putz oder anderen nichttragenden Schichten. Wird dieses Maß überschritten, müssen unter Umständen andere Befestigungssysteme gewählt werden.
	Kalksandlochstein	KS�12	Druckfestigkeit ≥/ = 12 N/mm ²		
	Hohlblockstein aus Leichtbeton	Hbl≥2	Druckfestigkeit ≥/ = 2 N/mm ²		

Montage ohne Ankerhülse FIS H12 x 85 K

Vollbaustoffe				Empfohlene Bohrart:
	Beton	≥ C12/15	Druckfestigkeit ≥/ = 15 N/mm ²	 Hammerbohren: Bohren mit Bohrhammer (harte Schläge, großer Bohrfortschritt) für Bohrungen, an die eine hohe Bohrqualität gestellt wird. Geeignet an Untergründe aus Vollstein mit dichtem Gefüge (Beton etc.). Bohrlöcher sind nach dem Bohren durch Ausblasen oder Aussaugen gründlich von Bohrrückständen zu reinigen. Schlagbohren: Bohren mit Schlagbohrmaschine (leichte Schläge) für Untergründe aus Mauerwerk mit dichtem Gefüge (z.B. Vollziegel, Kalksandvollstein). Bohrlöcher sind nach dem Bohren durch Ausblasen oder Aussaugen gründlich von Bohrrückständen zu reinigen. Hinweis: Das Set kann eingesetzt werden für Wände bis <u>max. 15 mm</u> Putz oder anderen nichttragenden Schichten. Wird dieses Maß überschritten, müssen unter Umständen andere Befestigungssysteme gewählt werden.
	Mauerziegel	Mz≥12	Druckfestigkeit ≥/ = 12 N/mm ²	
	Kalksandvollstein	KS≥12	Druckfestigkeit ≥/ = 12 N/mm ²	
	Vollstein aus Leichtbeton	V2	Druckfestigkeit ≥/ = 2 N/mm ²	

				Empfohlene Bohrart:
	Porenbeton	pp2	Druckfestigkeit ≥/ = 2 N/mm ²	 Drehbohren: Mit normaler Bohrmaschine <u>ohne Schlag</u> in Porenbeton. Bohrlöcher sind nach dem Bohren durch Ausblasen oder Aussaugen gründlich von Bohrrückständen zu reinigen. Dies gilt für alle angegebenen Materialien, jedoch muss besonders auf die Bohrlöcherreinigung im Porenbeton geachtet werden! Hinweis: Das Set kann eingesetzt werden für Wände bis <u>max. 15 mm</u> Putz oder anderen nichttragenden Schichten. Wird dieses Maß überschritten, müssen unter Umständen andere Befestigungssysteme gewählt werden.

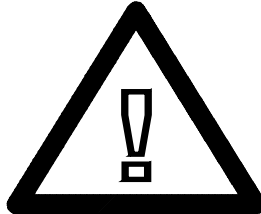

Bitte die beim Set beige packte Montageanleitung der Fa. Fischer Mat.Nr. 1537293 berücksichtigen, um eine sichere Montage zu gewährleisten!

E:**REQUIRED STRUCTURE OF WALL**

Attention! The nature of the wall must be checked carefully by **qualified personnel** before assembly. Assembly may then only be carried out by **qualified persons** who carefully observe these assembly instructions. The wall plugs Fischer SX 8x65 in standard set mat. no. 1535746 are only suitable if the characteristics of the wall and the pressure resistance levels are as stated in the table below. The unit must not be assembled on light walls or masonry. In all other cases it is essential that a different and appropriate type of mounting is chosen by a **qualified person**. hülsta cannot be held responsible for the correct choice of a different method of mounting. Please note that if the units are not mounted properly on the wall, there is a risk of the units falling down or tipping over – especially when alternative mounting materials acquired on site have been used. Generally speaking, you as a dealer/qualified fitter are responsible for the correct wall mounting of the units. During assembly please also make sure that there are no electrical installations or other utility lines near the mounting area. This must be checked using an appropriate search device. Please note that plastic pipes will not be detected.

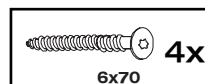
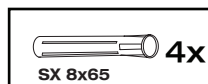
Standard set mat. no. 1535746

The standard set mat. no. 1535746 is only suitable for use in connection with the types of walls stated below. Please note that the pressure resistance levels must under no circumstances fall below those stated.

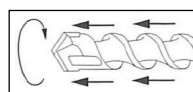
Concrete**Concrete****C12/15****Pressure resistance
>= 15 N/mm²****Recommended kind of drilling:**

Hammer (impact) drilling: Drilling with a hammer drill (high setting, better drilling progress) for holes which need to be of a high quality. Suitable for solid walls with a dense structure (concrete, etc). Drilled holes should be thoroughly cleaned after drilling by blowing or sucking out any remains.

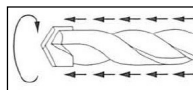

Percussion drilling: Drilling with a percussion drill (low setting) for brickwork of a dense structure (solid bricks, solid sand-lime bricks). Drilled holes should be thoroughly cleaned after drilling by blowing or sucking out any remains.

Note:





When drilling holes be sure to use sharp drill bits because otherwise the insertion torque for the screw will be too high and it will therefore be difficult to insert and tighten it.

The set can be used on walls up to a max. 15 mm of plastering or on any other non-load bearing surfaces. If this limit is exceeded it may be necessary to use different mounting methods.

Attention! The nature of the wall must be checked carefully by **qualified personnel** before assembly. Assembly may then only be carried out by **qualified persons** who carefully observe these assembly instructions. The set of assembly mortar mat. no. 1535747 must be used if the characteristics of the wall and the pressure resistance levels are as stated in the table below. The unit must not be assembled on light walls or masonry. In all other cases it is essential that a different and appropriate type of mounting is chosen by a **qualified person**. hülsta cannot be held responsible for the correct choice of a different method of mounting. Please note that if the units are not mounted properly on the wall, there is a risk of the units falling down or tipping over – especially when alternative mounting materials acquired on site have been used. Generally speaking, you as a dealer/qualified fitter are responsible for the correct wall mounting of the units. During assembly please also make sure that there are no electrical installations or other utility lines near the mounting area. This must be checked using an appropriate search device. Please note that plastic pipes will not be detected.

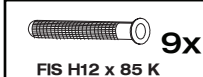



Set of assembly mortar mat. no. 1535747
(sufficient for 9 mountings)



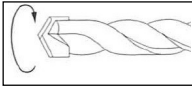

 9x FIS H12 x 85 K	 2x Static mixer	 1x
 9x FIS E 6x75 K		

The set is only suitable for use in connection with the types of walls stated below. Please note that the pressure resistance levels must under no circumstances fall below those stated.

Assembly with anchor sleeve FIS H12 x 85 K

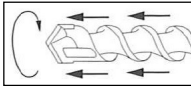
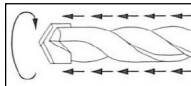
Perforated brick		Vertically perforated brick	$HL \geq 12$	Pressure resistance $\geq 12 \text{ N/mm}^2$ Tightness $\geq 1 \text{ kg/dm}^3$	Recommended kind of drilling:  Rotary drilling: With a normal power drill without percussion setting in perforated bricks (so that the connecting sections do not break and the hollow section becomes too large). Drilled holes should be thoroughly cleaned after drilling by blowing or sucking out any remains. Note: The set can be used on walls up to a <u>max. 15 mm</u> of plastering or on any other non-load bearing surfaces. If this limit is exceeded it may be necessary to use different mounting methods.
		Perforated sand-lime brick	$KSL \geq 12$	Pressure resistance $\geq 12 \text{ N/mm}^2$	
		Hollow bricks Hbl ≥ 2 of lightweight concrete		Pressure resistance $\geq 2 \text{ N/mm}^2$	

Assembly without anchor sleeve FIS H12 x 85 K

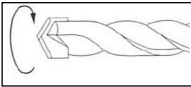
Solid brickwork		Concrete	$\geq C12/15$	Pressure resistance $\geq 15 \text{ N/mm}^2$	Recommended kind of drilling:  Hammer (impact) drilling: Drilling with a hammer drill (high setting, better drilling progress) for holes which need to be of a high quality. Suitable for solid walls with a dense structure (concrete, etc). Drilled holes should be thoroughly cleaned after drilling by blowing or sucking out any remains.  Percussion drilling: Drilling with a percussion drill (low setting) for brickwork of a dense structure (solid bricks, solid sand-lime bricks). Drilled holes should be thoroughly cleaned after drilling by blowing or sucking out any remains. Note: The set can be used on walls up to a <u>max. 15 mm</u> of plastering or on any other non-load bearing surfaces. If this limit is exceeded it may be necessary to use different mounting methods.
		Wall bricks	$Mz \geq 12$	Pressure resistance $\geq 12 \text{ N/mm}^2$	
		Sand-lime brick	$KS \geq 12$	Pressure resistance $\geq 12 \text{ N/mm}^2$	
		Solid brick of light concrete	V2	Pressure resistance $\geq 2 \text{ N/mm}^2$	
		Porous concrete	PP2	Pressure resistance $\geq 2 \text{ N/mm}^2$	Recommended kind of drilling:  Rotary drilling: With a normal power drill without percussion setting in porous concrete. Drilled holes should be thoroughly cleaned after drilling by blowing or sucking out any remains. This applies to all materials stated, however particular care should be taken when cleaning holes drilled in porous concrete! Note: The set can be used on walls up to a <u>max. 15 mm</u> of plastering or on any other non-load bearing surfaces. If this limit is exceeded it may be necessary to use different mounting methods.



Please observe assembly instructions mat. no. 1537293 of Fischer Co. included with the set in order to guarantee safe assembly!

F: CARACTERISTIQUES INDISPENSABLES POUR LA COMPOSITION DU MUR

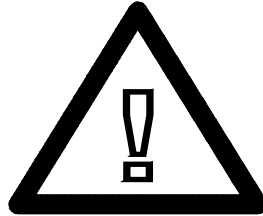

Attention! La nature des murs doit impérativement être contrôlée par un **spécialiste** avant le montage. Le montage ne doit être effectué que par un **spécialiste** en respectant soigneusement la notice de montage. Les chevilles Fischer SX 8x65 contenues dans le set de matériel n° 1535746 ne sont adaptées que lorsque la nature et la résistance à l'écrasement du mur sont toutes les deux mentionnées dans le tableau ci-dessous. Le montage dans de la maçonnerie légère est exclu. Dans tous les autres cas, il est impératif qu'un **spécialiste** choisisse une autre méthode de fixation adaptée. hülsta décline toute responsabilité pour le choix d'un autre type de fixation approprié. Veuillez remarquer qu'en présence d'une fixation murale non adaptée, il y a risque que le meuble tombe ou se renverse – tout particulièrement lors de l'utilisation de matériaux de fixation arbitrairement choisis sur place. Par principe en tant que vendeur/monteur qualifié, vous êtes responsable de la bonne fixation des meubles au mur. Lors du montage, il est également important de veiller à ce qu'aucune installation électrique ou autre conduit ne se trouvent dans le secteur de la fixation. Contrôlez leur présence avec un appareil de détection. Notez que les tubes en matière synthétique ne sont pas détectés.

Set de matériel n° 1535746

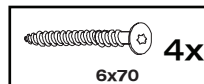
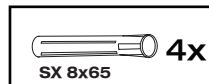

Le set de fixation murale contenu dans le set de matériel n° 1535746 n'est adapté que pour les murs dont la nature est mentionnée ci-dessous. Les valeurs inférieures données pour la résistance à l'écrasement doivent toujours être respectées.

Béton



Béton

C12/15

Résistance à l'écrasement
>= 15 N/mm²

Méthodes recommandées pour le perçage:

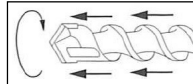

Perçage avec martèlement: chocs violents, grande progression, pour perçages demandant une grande qualité. Adapté aux maçonneries pleines à structure dense (béton, etc.). Les trous de perçage doivent être nettoyés soigneusement des résidus de forage à l'aide d'air comprimé ou par aspiration.

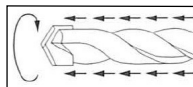

Perçage avec percussion: légers chocs, pour perçages dans maçonneries à structure dense (par exemple: brique pleine, parpaing plein). Les trous de perçage doivent être nettoyés soigneusement des résidus de forage à l'aide d'air comprimé ou par aspiration.

Remarque:

Ne pas utiliser un foret usagé pour le perçage, car le couple de serrage de la vis sera trop élevé et, en conséquence, la vis sera difficile à visser.

Le set peut être utilisé pour des murs avec un enduit ou un autre matériau non porteur d'une épaisseur maximale de 15 mm. Si cette épaisseur est dépassée, il est éventuellement nécessaire d'opter pour un autre système de fixation.

Attention! La nature des murs doit impérativement être contrôlée par un **spécialiste** avant le montage. Le montage ne doit être effectué que par un **spécialiste** en respectant soigneusement la notice de montage. Les sets de fixation avec mortier de montage n° 1535747 doivent être utilisés lorsque la nature et la résistance à l'écrasement du mur sont toutes les deux mentionnées dans le tableau ci-dessous. Le montage dans de la maçonnerie légère est exclu. Dans tous les autres cas, il est impératif qu'un **spécialiste** choisisse une autre méthode de fixation adaptée. hülsta décline toute responsabilité pour le choix d'un autre type de fixation approprié. Veuillez remarquer qu'en présence d'une fixation murale non adaptée, il y a risque que le meuble tombe ou se renverse – tout particulièrement lors de l'utilisation de matériaux de fixation arbitrairement choisis sur place. Par principe en tant que vendeur/monteur qualifié, vous êtes responsable de la bonne fixation des meubles au mur. Lors du montage, il est également important de veiller à ce qu'aucune installation électrique ou autre conduit ne se trouvent dans le secteur de la fixation. Contrôlez leur présence avec un appareil de détection. Notez que les tubes en matière synthétique ne sont pas détectés.

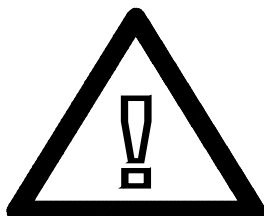

Set de fixation avec mortier de montage n° 1535747
(suffisant pour 9 points d'ancrage)

 9x FIS H12 x 85 K	 2x Mélangeur statique	 1x
 9x FIS E 6x75 K		

Le set n'est adapté que pour les murs dont la nature est mentionnée ci-dessous. Les valeurs inférieures données pour la résistance à l'écrasement doivent toujours être respectées.

Fixation avec manchon d'ancrage FIS H12 x 85 K

Matériaux de construction creux			Méthodes recommandées pour le perçage:	
	Briques à perforations verticales	HLz≥12	Résistance à l'écrasement >= 12 N/mm ² Densité >= 1 kg/dm ³	 Perçage rotatif: à l'aide d'une perceuse normale sans choc sur le parpaing (afin de ne pas endommager les cloisons et de ne pas faire un trou trop gros). Les trous de perçage doivent être nettoyés soigneusement des résidus de forage à l'aide d'air comprimé ou par aspiration.
	Parpaings silico-calcaires perforés	KSL≥12	Résistance à l'écrasement >= 12 N/mm ²	
	Parpaings creux en béton léger	Hbl≥2	Résistance à l'écrasement >= 2 N/mm ²	
Remarque:				Le set peut être utilisé pour des murs avec un enduit ou un autre matériau non porteur d'une épaisseur maximale de 15 mm. Si cette épaisseur est dépassée, il est éventuellement nécessaire d'opter pour un autre système de fixation.

Fixation sans manchon d'ancrage FIS H12 x 85 K

Matériaux de construction pleins			Méthodes recommandées pour le perçage:	
	Béton	≥ C12/15	Résistance à l'écrasement >= 15 N/mm ²	 Perçage avec martèlement: chocs violents, grande progression, pour perçages demandant une grande qualité. Adapté aux maçonneries pleines à structure dense (béton, etc.). Les trous de perçage doivent être nettoyés soigneusement des résidus de forage à l'aide d'air comprimé ou par aspiration.
	Brique pleine	Mz≥12	Résistance à l'écrasement >= 12 N/mm ²	
	Parpaings pleins silico-calcaires	KS≥12	Résistance à l'écrasement >= 12 N/mm ²	 Perçage avec percussion: légers chocs, pour perçages dans maçonneries à structure dense (par exemple: brique pleine, parpaing plein). Les trous de perçage doivent être nettoyés soigneusement des résidus de forage à l'aide d'air comprimé ou par aspiration.
	Parpaings pleins en béton léger	V2	Résistance à l'écrasement >= 2 N/mm ²	
Remarque:				Le set peut être utilisé pour des murs avec un enduit ou un autre matériau non porteur d'une épaisseur maximale de 15 mm. Si cette épaisseur est dépassée, il est éventuellement nécessaire d'opter pour un autre système de fixation.

Matériaux de construction pleins			Méthodes recommandées pour le perçage:	
	Béton cellulaire	PP2	Résistance à l'écrasement >= 2 N/mm ²	 Perçage rotatif: à l'aide d'une perceuse normale sans choc sur le béton cellulaire. Les trous de perçage doivent être nettoyés soigneusement des résidus de forage à l'aide d'air comprimé ou par aspiration. Cela est applicable à tous les matériaux. Malgré tout, il faut particulièrement bien nettoyer les perçages dans le béton cellulaire!
Remarque:				Le set peut être utilisé pour des murs avec un enduit ou un autre matériau non porteur d'une épaisseur maximale de 15 mm. Si cette épaisseur est dépassée, il est éventuellement nécessaire d'opter pour un autre système de fixation.

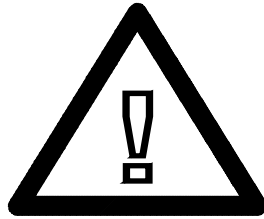

Veuillez respecter le mode d'emploi de la société Fischer joint au matériel n° 1537293, afin de garantir un bon montage!

NL:**VEREISTE WANDSTRUCTUUR**

N.B.! Alvorens met de montage te beginnen moet absoluut eerst de structuur van de wand door een **vakman** worden gecontroleerd. De montage mag uitsluitend worden uitgevoerd door een **vakman** onder voorwaarde dat deze de montagehandleiding zorgvuldig in acht neemt. De in het standaardset mat.nr. 1535746 bijgevoegde Fischer kunststofpluggen SX 8x65 zijn uitsluitend geschikt indien wandstructuren en druksterkten overeenkomen met de gegevens in onderstaande tabel. In andere, afwijkende gevallen moet door de **vakman** persé voor een andere, geschikte aard van bevestiging gekozen worden. Voor het vakkundig kiezen van een andere aard van bevestiging is hülsta niet aansprakelijk. Houdt u er a.u.b. ook rekening mee dat bij een onvakkundige bevestiging van meubelen aan de wand het risico bestaat dat deze van de wand kunnen vallen resp. kunnen omkantelen – vooral bij gebruik van door de klant zelf aangeschafte, alternatieve bevestigingsmaterialen. Normaal bent u als meubelhandelaar/vakmonteur verantwoordelijk voor de vakkundige wandbevestiging. Bij het monteren moet er bovendien op gelet worden dat zich ter hoogte van de bevestigingspunten geen elektro-installatiezones en geen toe- en afvoerleidingen bevinden. Dit dient met een hiervoor geschikte detector gecontroleerd te worden. Houd er rekening mee dat het niet mogelijk is buizen van kunststof te detecteren.

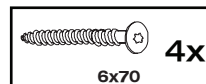
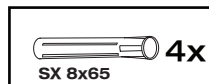
Standaardset mat.nr. 1535746

De standaardset mat.nr. 1535746 is uitsluitend geschikt voor de hierna genoemde wandstructuren. De druksterktes mogen in geen geval lager zijn dan de hieronder aangegeven druksterktes.

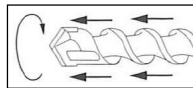
Beton**Beton****C12/15****Druksterkte
≥ 15 N/mm²****Aan te bevelen boren:**

Hamerboor: met een hamerboor (hard slagwerk, snel boorresultaat) voor boringen, waaraan een hoge boorkwaliteit gesteld worden. Te gebruiken voor wanden van volle steen met een dichte structuur (bijv. beton etc.). Boorgaten dienen na het boren door uitblazen of uitzuigen grondig van boorresten te worden gereinigd.

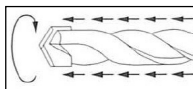

Klopboor: met een klopboormachine (licht slagwerk) boren in metselwerk met een dichte structuur (bijv. wanden van volle baksteen, volle kalkzandsteen). Boorgaten dienen na het boren door uitblazen of uitzuigen grondig van boorresten te worden gereinigd.

Aanwijzing:

Voor gaten boren geen versleten boor gebruiken omdat anders het aandraaimoment van de schroef te hoog wordt en het aandraaien ervan moeilijk zal gaan.

De set kan worden gebruikt voor wanden met tot **max. 15 mm** stucwerk of andere niet dragende lagen. Als deze afm. overschreden wordt, moeten onder omstandigheden andere bevestigingsystemen worden gekozen.

N.B.! Alvorens met de montage te beginnen moet absoluut eerst de structuur van de wand door een **vakman** worden gecontroleerd. De montage mag uitsluitend worden uitgevoerd door een **vakman** onder voorwaarde dat deze de montagehandleiding zorgvuldig in acht neemt. De bevestigingssets met montagemortel mat.nr. 1535747 moet worden gebruikt als de kwaliteit/hoedanigheid van de wand en de druksterktes overeenkomen met de gegevens in de onderstaande tabel. In andere, afwijkende gevallen moet door de **vakman** persé voor een andere, geschikte aard van bevestiging gekozen worden. Voor het vakkundig kiezen van een andere aard van bevestiging is húlsta niet aansprakelijk. Houdt u er a.u.b. ook rekening mee dat bij een onvakkundige bevestiging van meubelen aan de wand het risico bestaat dat deze van de wand kunnen vallen resp. kunnen omkantelen – vooral bij gebruik van door de klant zelf aangeschafte, alternatieve bevestigingsmaterialen. Normaal bent u als meubelhandelaar/vakmonteur verantwoordelijk voor de vakkundige wandbevestiging. Bij het monteren moet er bovendien op gelet worden dat zich ter hoogte van de bevestigingspunten geen elektro-installatiezones en geen toe- en afvoleidingen bevinden. Dit dient met een hiervoor geschikte detector gecontroleerd te worden. Houd er rekening mee dat het niet mogelijk is buizen van kunststof te detecteren.

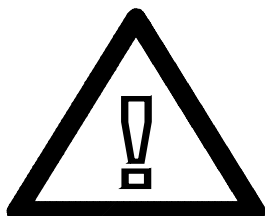

Bevestigingssets met montagemortel mat.nr. 1535747
(voldoende voor 9 verankerings)

 9x FIS H12 x 85 K	 2x Statische mixer	 1x
 9x FIS E 6x75 K		

De bevestigingsset is uitsluitend geschikt voor de hierna genoemde wandstructuren. De druksterktes mogen in geen geval lager zijn dan de hieronder aangegeven druksterktes.

Bevestiging met ankerhuls FIS H12 x 85 K

Geperforeerde bouwmaterialen

	Verticaal geperforeerde baksteen	HL\geq12	Druksterkte \geq 12 N/mm² Soortelijk gewicht \geq 1 kg/dm³
	Geperforeerde kalkzandsteen	KSL\geq12	Druksterkte \geq 12 N/mm²
	Holle baksteen van lichtbeton	Hbl\geq2	Druksterkte \geq 2 N/mm²

Aan te bevelen boren:

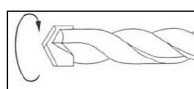

Draaiboor: met een normale boormachine (**zonder slagwerk**) boren in holle steen (opdat de holtes in het bouw materiaal niet uitbreken en het boorgat niet te groot wordt). Boorgaten dienen na het boren door uitblazen of uitzuigen grondig van boorresten te worden gereinigd.

Aanwijzing:

De set kan worden gebruikt voor wanden met tot max. 15 mm stucwerk of andere niet dragende lagen. Als deze afm. overschreden wordt, moeten onder omstandigheden andere bevestigingsystemen worden gekozen.

Bevestiging zonder ankerhuls FIS H12 x 85 K

Dichte bouwmaterialen

	Beton	\geq C12/15	Druksterkte \geq 15 N/mm²
	Bouwstenen	M\geq12	Druksterkte \geq 12 N/mm²
	Massieve kalkzandstenen	KS\geq12	Druksterkte \geq 12 N/mm²
	Massieve bakstenen van lichtbeton	V2	Druksterkte \geq 2 N/mm²

Aan te bevelen boren:

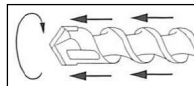

Hammerboor: met een hamerboor (hard slagwerk, snel boorresultaat) voor boringen, waaraan een hoge boorkwaliteit gesteld worden. Te gebruiken voor wanden van volle steen met een dichte structuur (bijv. beton etc.). Boorgaten dienen na het boren door uitblazen of uitzuigen grondig van boorresten te worden gereinigd.

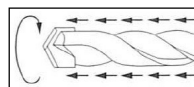

Klopboor: met een klopboormachine (licht slagwerk) boren in metselwerk met een dichte structuur (bijv. wanden van volle baksteen, volle kalkzandsteen). Boorgaten dienen na het boren door uitblazen of uitzuigen grondig van boorresten te worden gereinigd.

Aanwijzing:

De set kan worden gebruikt voor wanden met tot max. 15 mm stucwerk of andere niet dragende lagen. Als deze afm. overschreden wordt, moeten onder omstandigheden andere bevestigingsystemen worden gekozen.



Cellenbeton	PP2	Druksterkte \geq 2 N/mm²
--------------------	------------	---

Aan te bevelen boren:

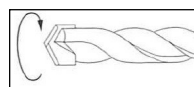

Draaiboor: met een normale boormachine (**zonder slagwerk**) boren in porenbeton. Boorgaten dienen na het boren door uitblazen of uitzuigen grondig van boorresten te worden gereinigd. Dit geldt voor alle aangegeven materialen maar vooral in het geval van cellenbeton is de boorgatreiniging uiterst belangrijk!

Aanwijzing:

De set kan worden gebruikt voor wanden met tot max. 15 mm stucwerk of andere niet dragende lagen. Als deze afm. overschreden wordt, moeten onder omstandigheden andere bevestigingsystemen worden gekozen.



A.u.b. de bij de set bijgevoegde montagehandleiding van de Fa. Fischer, mat.nr. 1537293, in acht nemen om een veilige montage zeker te stellen!

RUS: НЕОБХОДИМАЯ КОНСТРУКЦИЯ СТЕНЫ

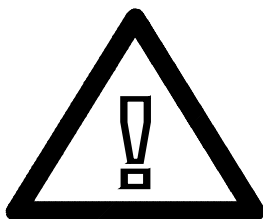

Внимание! Свойства стены должны быть тщательно проверены квалифицированным персоналом перед осуществлением монтажа. После этого монтаж может осуществляться квалифицированным персоналом, который строго соблюдает инструкции по монтажу. Для данной цели подходят только заглушки Fischer SX 8x65 в стандартном наборе, мат. № 1535746, если характеристики стены и уровень предела прочности соответствуют указанным в приведенной ниже таблице. Предмет мебели не должен быть навешен на стены из гипсокартона и легкой кирпичной кладки. Во всех остальных случаях необходимо, чтобы другой и соответствующий тип крепления выбирался квалифицированным специалистом. „Хюльста“ не несет ответственность за правильность выбора другого способа монтажа. Обратите внимание, что если предметы мебели надлежащим образом не закреплены на стене, существует риск, что они могут падать или опрокидываться - особенно, когда использовались альтернативные материалы, приобретенные в интернете. В целом, вы как дилер / квалифицированный монтажник отвечаете за правильность монтажа и крепления на стену мебели. Во время монтажа убедитесь в отсутствии электрической проводки и других инженерных коммуникаций вблизи места монтажа. Проверка осуществляется с помощью соответствующего поискового устройства(тестера). Обратите внимание, что пластиковые трубки не обнаруживаются.

Стандартный набор материалов № 1535746

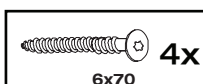
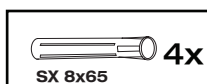

Стандартный набор материалов № 1535746 подходит только для типов стен, указанных ниже. Обратите внимание, что уровни предела прочности ни при каких обстоятельствах не должны быть ниже указанных.

Бетон



Бетон

C12/15

Предел прочности
>= 15 Н/мм²

Рекомендованный тип сверления:

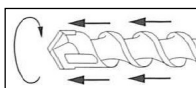

Ударное сверление: ударное сверление (выше настройки, лучше процесс сверления) отверстий, которые должны быть высокого качества. Подходит для твердых стен с плотной структурой (бетон и т.д.). Отверстия должны быть тщательно очищены после сверления путем продувки и извлечения любых остатков.

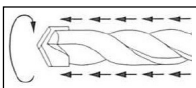

Вибрационно-вращательное сверление: сверление с помощью дрели ударного действия (пониженная настройка) для кирпичной кладки плотной структуры (полнотелого кирпича, твердого силикатного кирпича). Отверстия должны быть тщательно очищены после сверления путем продувки и извлечения любых остатков.

Примечание:

При сверлении отверстий обязательно используйте острые сверла, так как в противном случае крутящий момент для винта будет слишком высоким, и поэтому будет трудно вставить и затянуть винт.

Набор может быть использован на стенах со штукатуркой максимум 15 мм или на других поверхностях не несущих нагрузку. Если этот предел превышен, может быть необходимо использовать другие методы монтажа.



Внимание! Состав стены должен быть тщательно проверен квалифицированным персоналом перед осуществлением монтажа. После этого монтаж может осуществляться квалифицированным персоналом, который строго соблюдает инструкции по монтажу. Необходимо использовать набор монтажного материала с раствором № 1535747, если характеристики стены и уровень предела прочности соответствуют указанным ниже в таблице. Предмет мебели не должен крепиться на облегченные тонкие стены. Во всех остальных случаях необходимо, чтобы другой и

соответствующий тип крепления выбирался квалифицированным специалистом. „Хюльста“ не несет ответственность за правильность выбора другого способа монтажа.

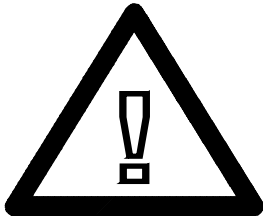
Обратите внимание, что если мебель надлежащим образом не закреплена на стене, существует риск, что она может упасть или опрокинуться - особенно, когда использовались альтернативные материалы, приобретенные в интернете. В целом, вы как дилер / квалифицированный монтажник отвечаете за правильность крепления предметов мебели на стене. Во время монтажа убедитесь в отсутствии электрической проводки и других инженерных коммуникаций вблизи места крепления. Проверка осуществляется с помощью соответствующего поискового устройства (тестера). Обратите внимание, что пластиковые трубы не обнаруживаются.

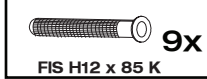

Комплект монтажного материала с раствором № 1535747
(достаточно для 9 креплений)

 9x FIS H12 x 85 K	 2x Статический смеситель	 1x
 9x FIS E 6x75 K		

Набор предназначен только для использования для типов стен, указанных ниже. Обратите внимание, что уровни предела прочности ни при каких обстоятельствах не должны быть ниже указанных.

Монтаж с анкерной втулкой FIS H12 x 85 K

Перфорированный кирпич		Дырчатый кирпич		HL_Z ≥ 12	Предел прочности >= 12 Н/мм ² Плотность/Объемный вес >= 1 кг/дм ³	Recommended kind of drilling:  Роторное сверление: Использование дрели номинальной мощности без ударных параметров для перфорированного (пустотелого) кирпича (для того, чтобы соединительные участки не ломались и полый участок не становился слишком большим). Отверстия должны быть тщательно очищены после сверления путем продувки или извлечения любых остатков.
Перфорированный силикатный кирпич		Перфорированный силикатный кирпич		KSL ≥ 12	Предел прочности >= 12 Н/мм ²	
Полые кирпичи из легкого бетона		Полые кирпичи из легкого бетона		Hb_L ≥ 2	Предел прочности >= 2 Н/мм ²	
Примечание:						Набор может быть использован на стенах со штукатуркой максимум 15 мм или на других поверхностях не несущих нагрузку. Если этот предел превышен, может быть необходимо использовать другие методы монтажа.

Монтаж без анкерной втулки FIS H12 x 85 K

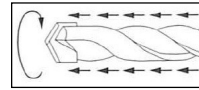
Сплошная кирпичная кладка		Бетон		≥ C12/15	Предел прочности >= 15 Н/мм ²	Рекомендованный тип сверления:  Ударное сверление: ударное сверление (выше настройки, лучше процесс сверления) отверстий, которые должны быть высокого качества. Подходит для твердых стен с плотной структурой (бетон и т.д.). Отверстия должны быть тщательно очищены после сверления путем продувки и извлечения любых остатков.  Вибрационно-вращательное сверление: сверление с помощью дрели ударного действия (пониженная настройка) для кирпичной кладки плотной структуры (полнотелого кирпича, твердого силикатного кирпича). Отверстия должны быть тщательно очищены после сверления путем продувки и извлечения любых остатков.
Стеновой кирпич		Стеновой кирпич		M_Z ≥ 12	Предел прочности >= 12 Н/мм ²	
Силикатный кирпич		Силикатный кирпич		KS ≥ 12	Предел прочности >= 12 Н/мм ²	
Сплошной кирпич из легкого бетона		Сплошной кирпич из легкого бетона		V2	Предел прочности >= 2 Н/мм ²	Примечание:
Примечание:						Набор может быть использован на стенах со штукатуркой максимум 15 мм или на других поверхностях не несущих нагрузку. Если этот предел превышен, может быть необходимо использовать другие методы монтажа.

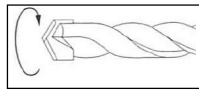
Пористый бетон		PP2		PP2	Предел прочности >= 2 Н/мм ²	Рекомендованный тип сверления:  Роторное сверление: Использование дрели номинальной мощности без ударных параметров для перфорированного (пустотелого) кирпича (для того, чтобы соединительные участки не ломались и полый участок не становился слишком большим). Отверстия должны быть тщательно очищены после сверления путем продувки или извлечения любых остатков.
Примечание:						



Пожалуйста, соблюдайте инструкцию по сборке мат. № 1537293 Fischer Co., находящуюся вместе с комплектом, для гарантии безопасного монтажа!

RC:

墙体所需结构

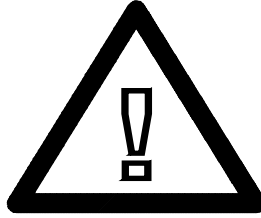

注意！墙体属性必须在安装前由合格的专业人员进行检查。之后应当由熟读安装指导的专业合格人员进行安装。标准配置材料No.1535746的墙壁插座 Fischer SX 8x65 仅适用于下表中所列特性和抗压水平的墙体。柜子不能安装在轻质墙或砌体墙上。在其他任何情况下，重要的是，不同的相应合适类型的壁挂支架必须由合格的专业人员进行选择。对于不同壁挂方式的正确选择与否，hülsta对其不承担相应责任。请注意，如果柜子没有正确地安装在墙上，那么存在柜子掉落或翻倒的风险 – 尤其是当现场获得的备选安装材料已被使用时。通常来说，你作为代理商/合格的专业安装工，有责任将柜子正确地安装在墙上。在装配过程中，请确保装配区域附近没有电气设施或者公用事业管线设施。其必须使用相应合适的搜索设备进行检测。请注意，塑料管是无法被（此搜索设备）检测到的。

标准配置材料No.1535746



标准配置材料No.1535746仅适用于与下面所述类型有关的墙壁的使用。请注意，抗压水平值在任何情况下都必须低于下面所述。

混凝土



混凝土

C12/15

抗压值
>= 15 N/mm²

建议钻孔类型：

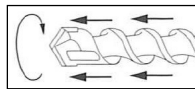

锤（冲击）钻：

对于高品质要求的钻孔，使用锤（冲击）钻（高设置，较好的钻探进度）。适用于具有致密结构（混凝土等）实心墙。钻孔后应使用吹或吸等方法彻底清洁孔内任何残留物。

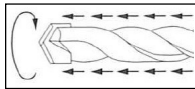

冲击钻：

对于致密结构砌体墙（实心砖，实心灰砂砖），使用冲击钻（低设置）。钻孔后应使用吹或吸等方法彻底清洁孔内任何残留物。

注意：



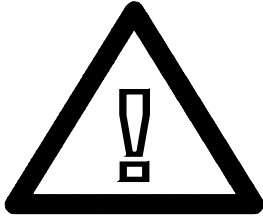

确保钻孔时使用锋利的钻头，否则螺钉的插入扭矩会太高而导致它难以插入和拧紧。

此套装可用于最大15mm的石膏“墙”或其他任何非承重“墙”。

注意！墙体属性必须在安装前由合格的专业人员进行检查。之后应当由熟读安装指导的专业合格人员进行安装。此组砂浆安装材料No.1535747必须使用于下表中所列特性和抗压水平的墙体。柜子不能安装于轻质墙或者砂浆墙体。柜子不能安装在轻质墙或砌体墙上。在其他任何情况下，重要的是，不同的相应合适类型的壁挂支架必须由合格的专业人员进行选择。对于不同壁挂方式的正确选择与否，hülsta对其不承担相应责任。请注意，如果柜子没有正确地安装在墙上，那么存在柜子掉落或翻倒的风险 – 尤其是当现场获得的备选安装材料已被使用时。通常来说，你作为代理商/合格的专业安装工，有责任将柜子正确地安装在墙上。在装配过程中，请确保装配区域附近没有电气设施或者公用事业管线设施。其必须使用相应合适的搜索设备进行检测。请注意，塑料管是无法被（此搜索设备）检测到的。

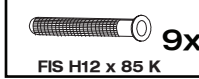



套装砂浆安装材料No.1535747
(足够9件安装)



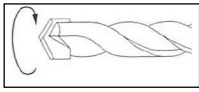

 9x FIS H12 x 85 K	 2x 静态混合器	 1x
 9x FIS E 6x75 K		

此套装仅适用于与下面所述类型有关的墙壁的使用。请注意，抗压水平值在任何情况下都必须低于下面所述。

使用锚定套筒FIS H12 x 85 K安装

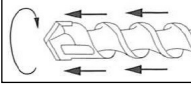
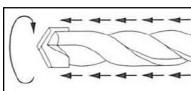
多孔砖		垂直多孔砖	HLz≥12	抗压值 ≥ 12 N/mm ² 紧固度 ≥ 1 kg/dm ³	建议钻孔类型  旋转钻孔： 使用正常的动力钻孔，不再多孔砖上敲击设置（以防止连接部位断裂而使空心部分变大）。钻孔后应使用吹或吸等方法彻底清洁孔内任何遗留物。 注意： 此套装可用于最大15mm的石膏“墙”或其他任何非承重“墙”。
		多孔灰砂砖	KSL≥12	抗压值 ≥ 12 N/mm ²	
		轻质混凝土空心砖	Hbl≥2	抗压值 ≥ 2 N/mm ²	

不使用锚定套筒FIS H12 x 85 K安装

实心砖		混凝土	≥ C12/15	抗压值 ≥ 15 N/mm ²	建议钻孔类型  锤（冲击）钻： 对于高品质要求的钻孔，使用锤（冲击）钻（高设置，较好的钻探进度）。适用于具有致密结构（混凝土等）实心墙。钻孔后应使用吹或吸等方法彻底清洁孔内任何遗留物。  冲击钻： 对于致密结构砌体墙（实心砖，实心灰砂砖），使用冲击钻（低设置）。钻孔后应使用吹或吸等方法彻底清洁孔内任何遗留物。 注意： 此套装可用于最大15mm的石膏“墙”或其他任何非承重“墙”。
		墙砖	Mz≥12	抗压值 ≥ 12 N/mm ²	
		灰砂砖	KS≥12	抗压值 ≥ 12 N/mm ²	
		轻质混凝土实心砖	V2	抗压值 ≥ 2 N/mm ²	

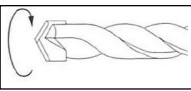
	多孔混凝土	PP2	抗压值 ≥ 2 N/mm ²	建议钻孔类型  旋转钻孔： 使用正常的动力钻孔，不再多孔砖上敲击设置（以防止连接部位断裂而使空心部分变大）。钻孔后应使用吹或吸等方法彻底清洁孔内任何遗留物。 注意： 此套装可用于最大15mm的石膏“墙”或其他任何非承重“墙”。
---	--------------	------------	-------------------------------------	--



请遵守Fischer Co.物料No.1537293及其套装的安装说明指导，以保证安全安装！

Wandbefestigung Beschlag 819

wall mounting bracket 819
 Ferrure de montage mural 819
 wandbevestigingsbeslag 819

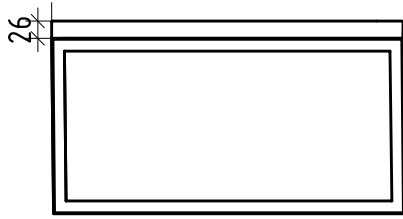

Position Wandbeschlag anhand des Korpusse bestimmen.

Determine position of wall bracket based on carcass.
 Déterminer la position de la ferrure murale en fonction du corps.
 Positie van de wandbevestiging aan hand van de elementromp bepalen.

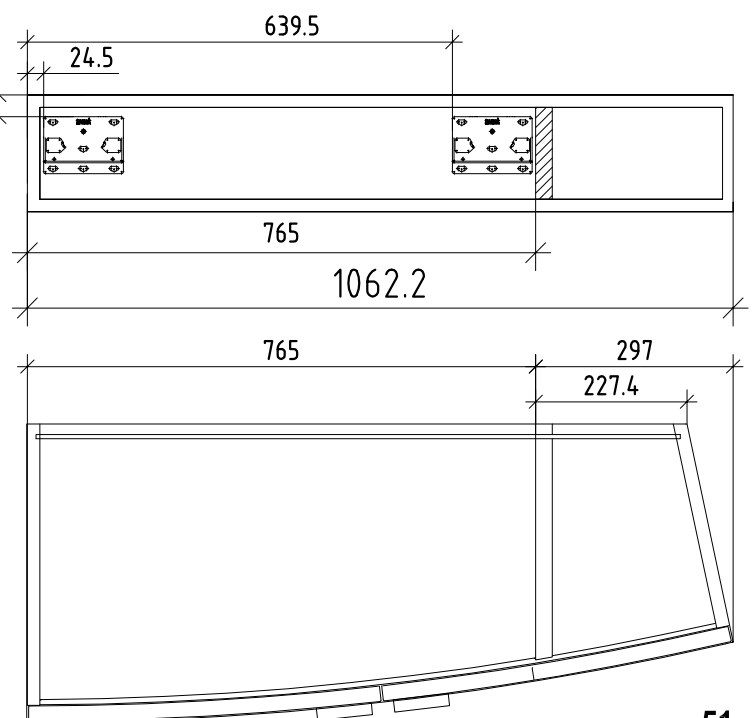
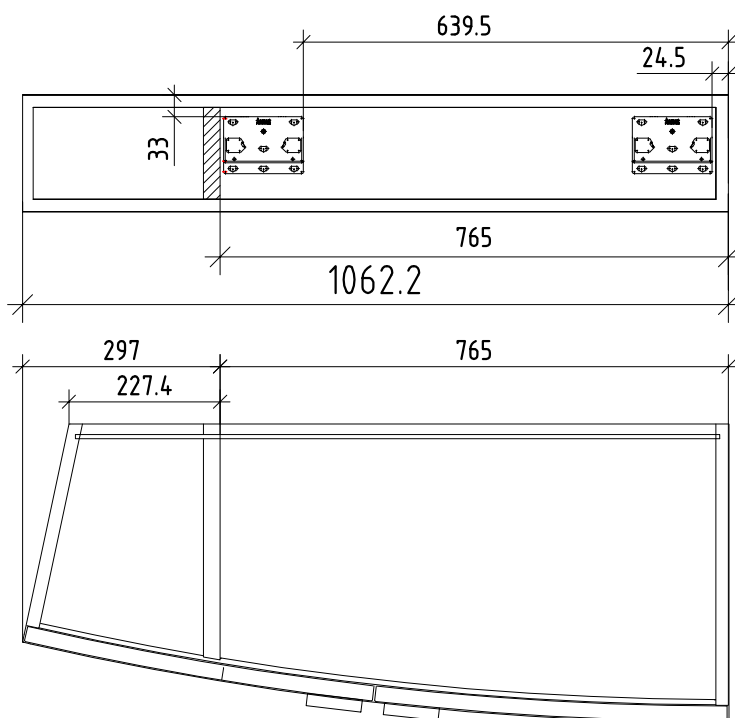
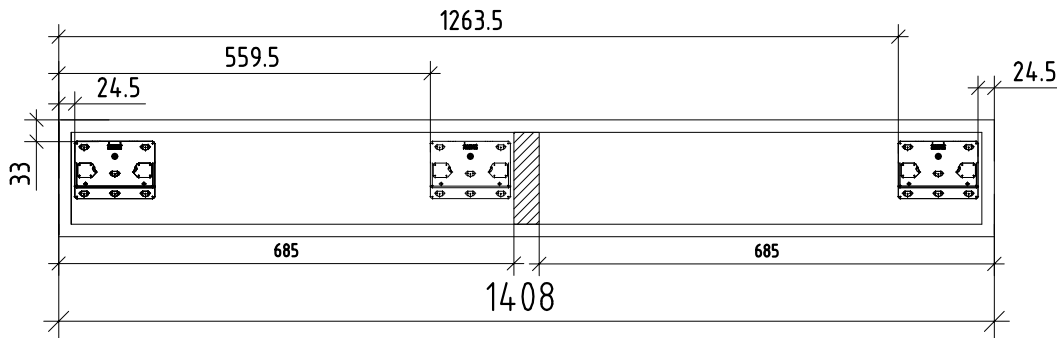
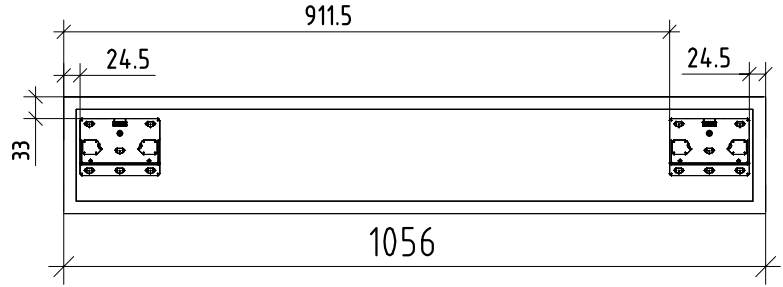
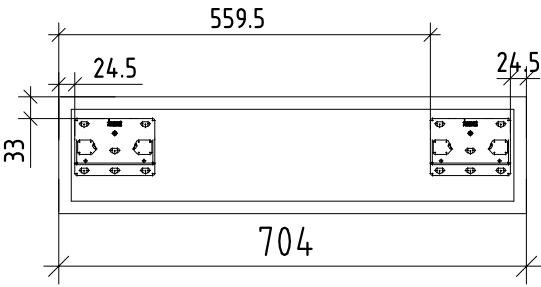
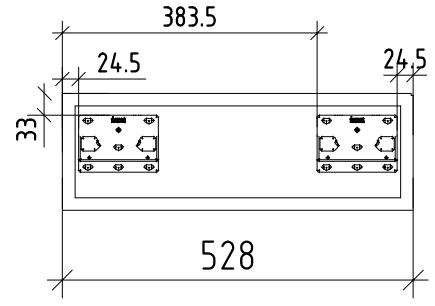
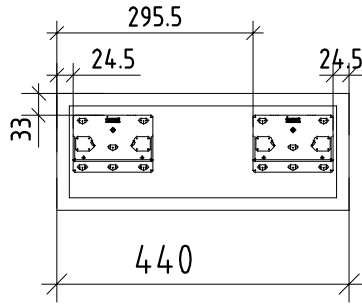
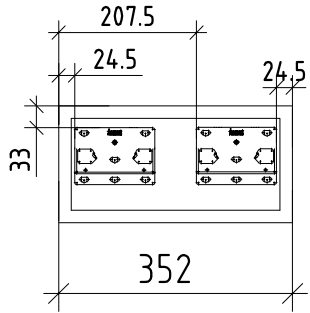
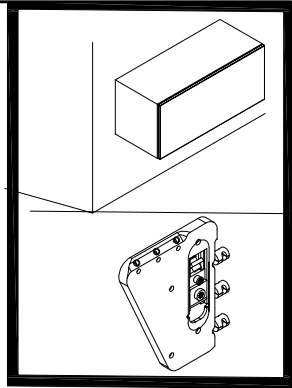

2

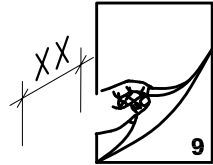
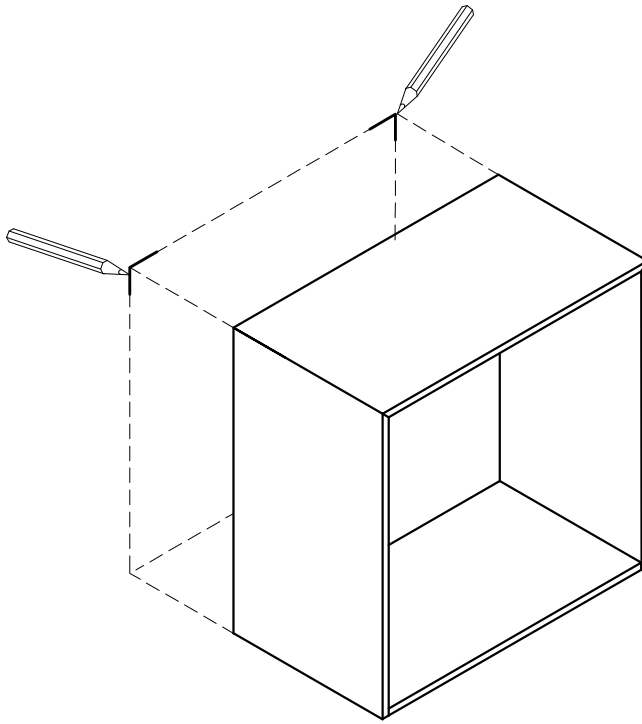
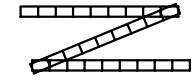

3

BB 2509
BB 2510

BB 2511

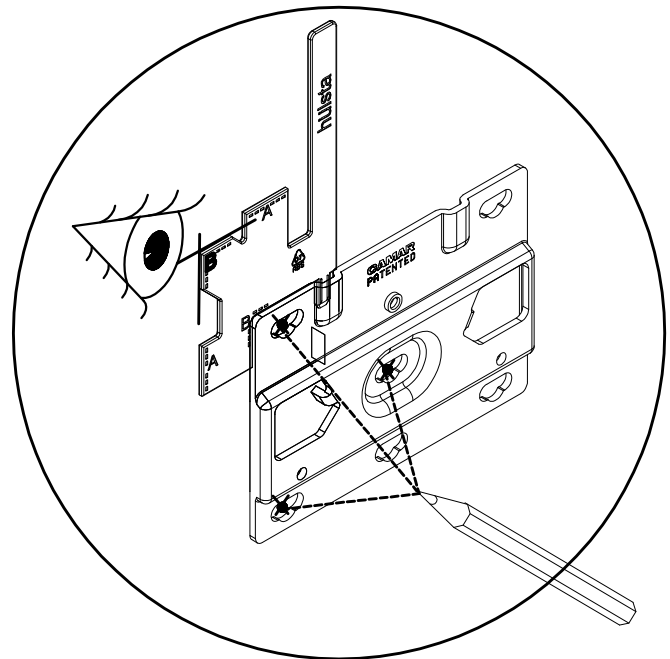
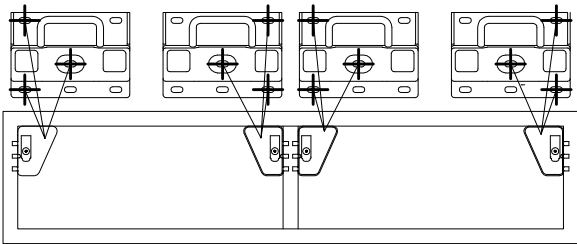
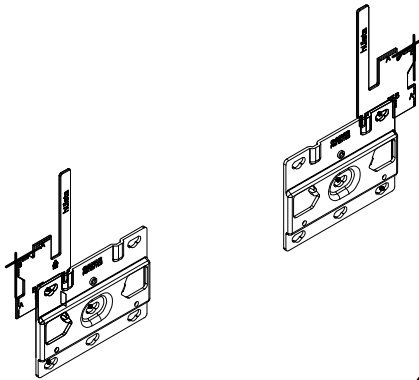

4

BB 2543

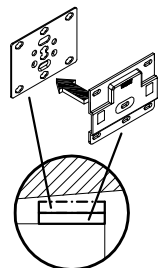
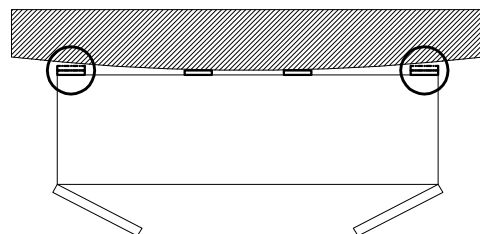
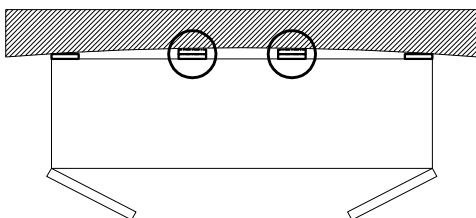

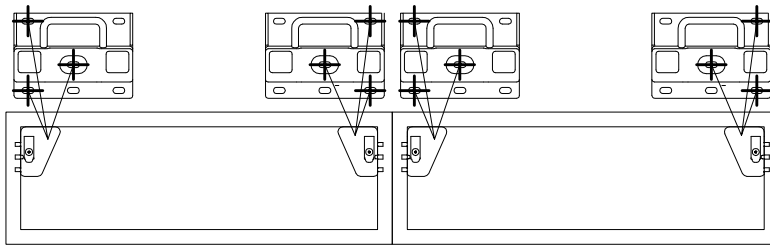

5

Befestigung mit Standard Set
 Assembly with standard set
 Montage avec set de standard
 montage met standaardset
 Монтаж со стандартным
 набором
 使用标准组件安装



BB 2460

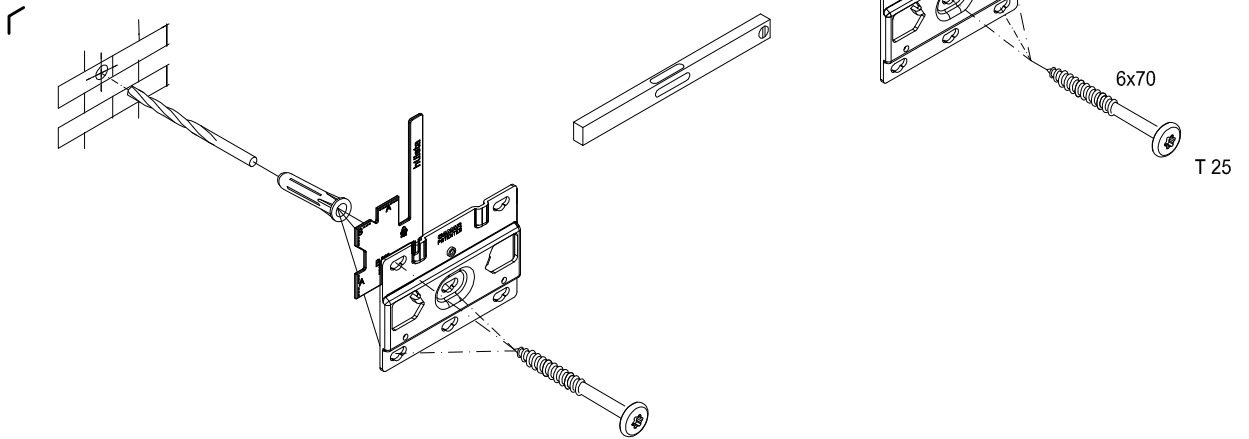

5

Befestigung mit Ankerhülse
 Assembly with anchor sleeve
 Montage avec manchon d'ancrage
 montage met ankerhulzen
 Монтаж с анкерной втулкой
 使用轴套安装

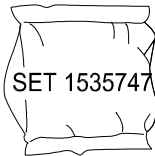

SET 1535747

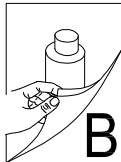

Mat. Nr. 1537293

SET

Mat. 1535747

9x		FIS H 12x85 K
9x		FIS EK 6x75
1x		
2x		

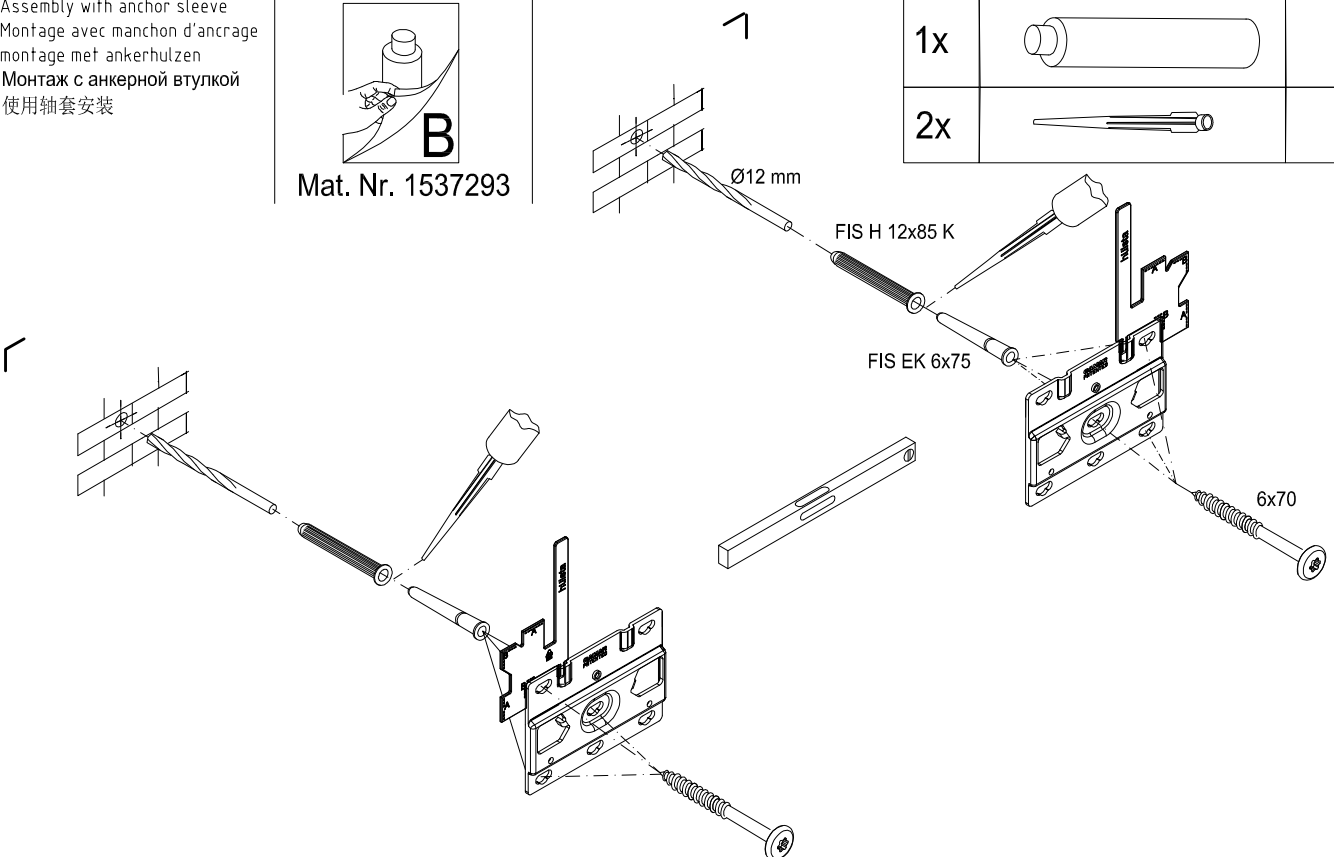

5

Befestigung ohne Ankerhülse
Assembly without anchor sleeve
Montage sans manchon d'ancrage
Montage zonder ankerhulzen
Монтаж без анкерной втулки
不使用轴套安装

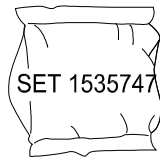

Mat. Nr. 1537293

SET

Mat. 1535747

9x		FIS H 12x85 K
9x		FIS EK 6x75
1x		
2x		

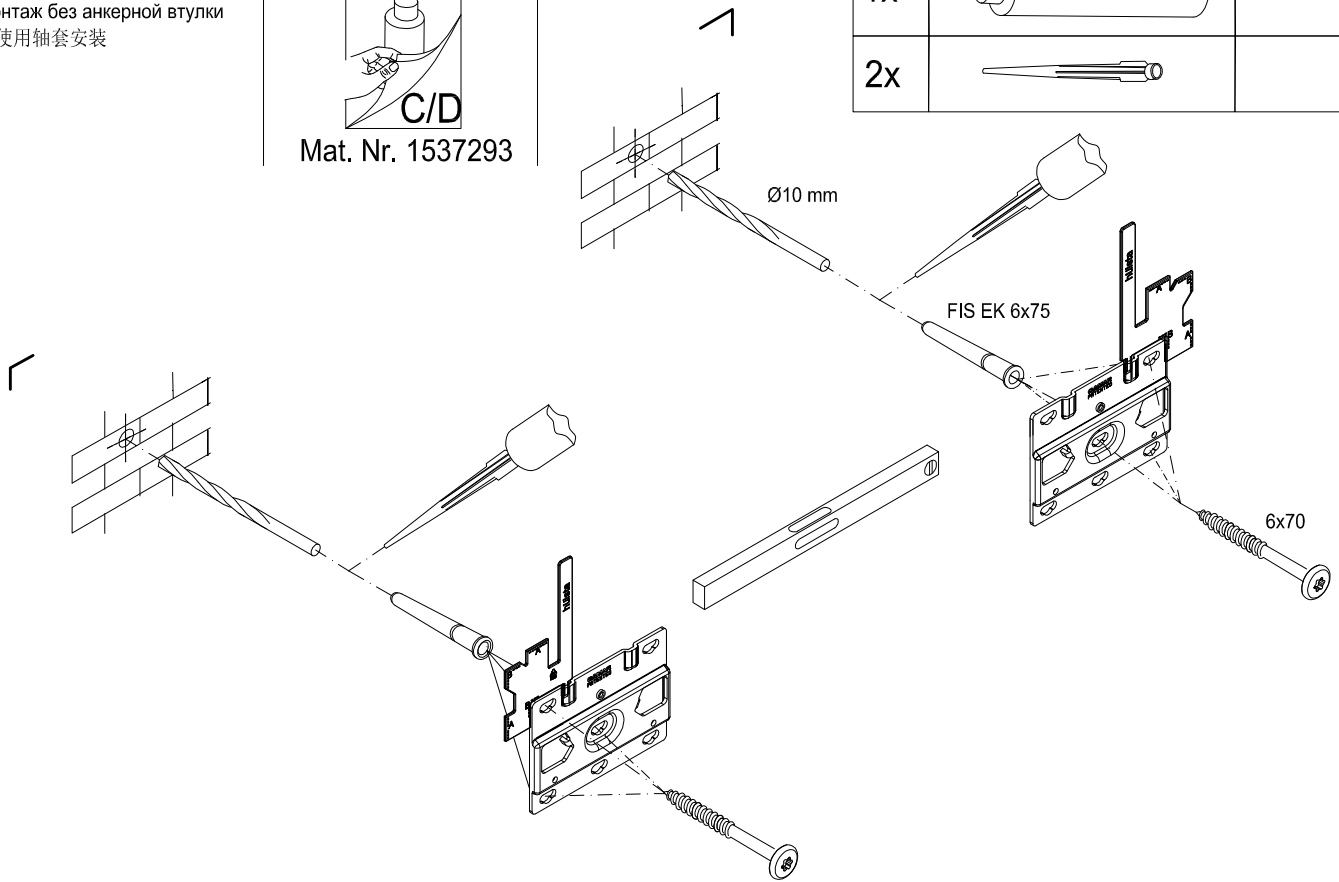

6

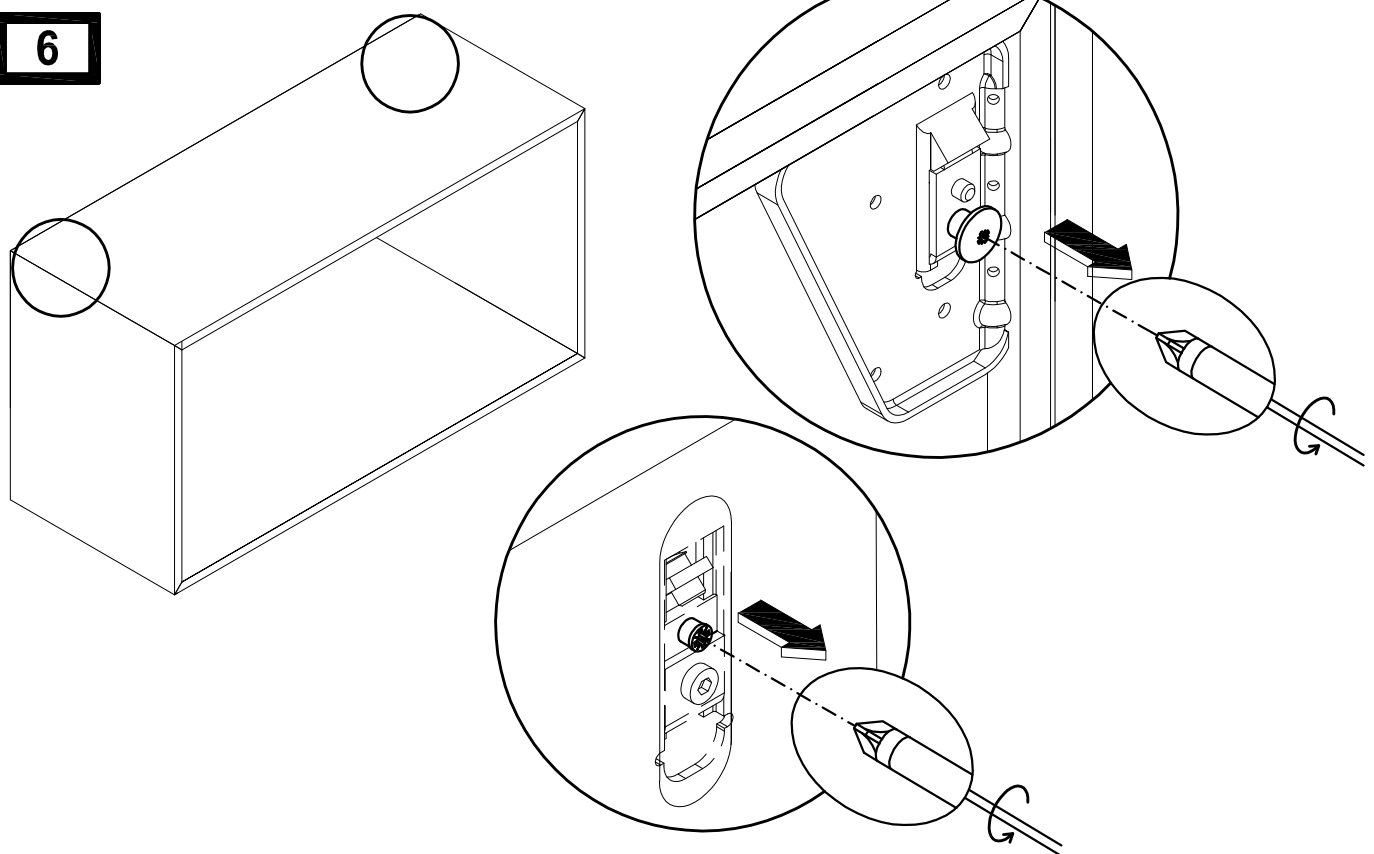

7

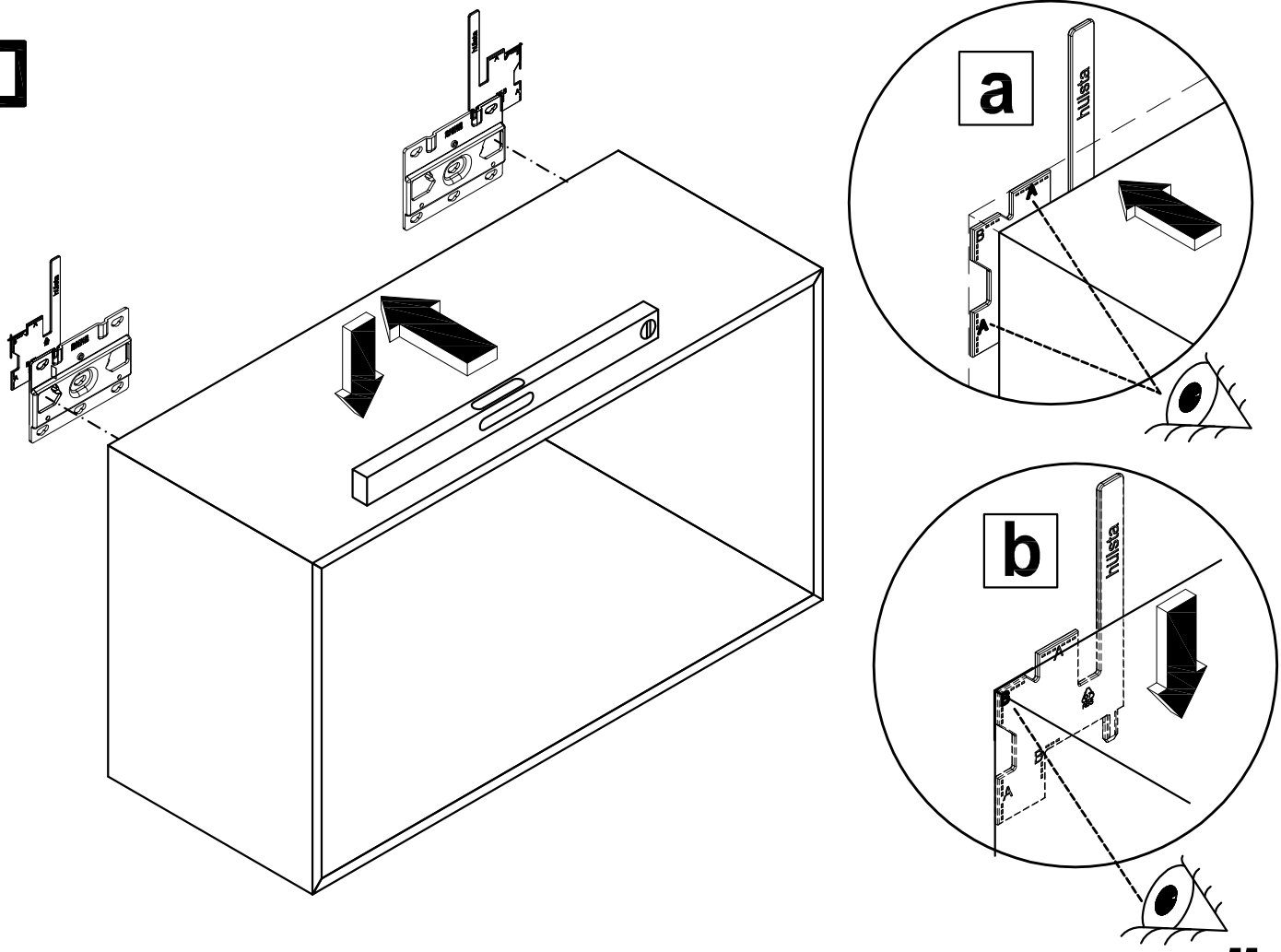

8

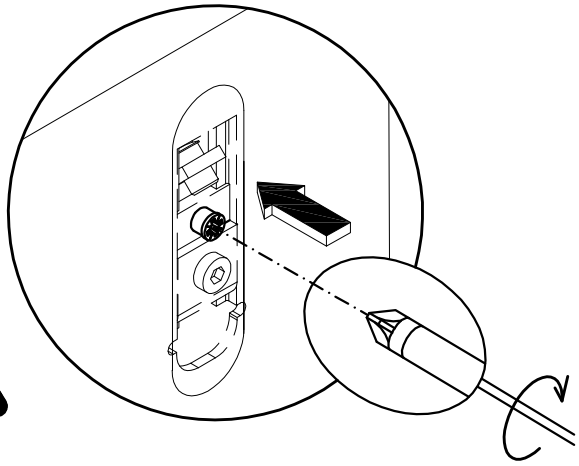
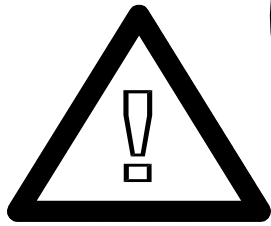
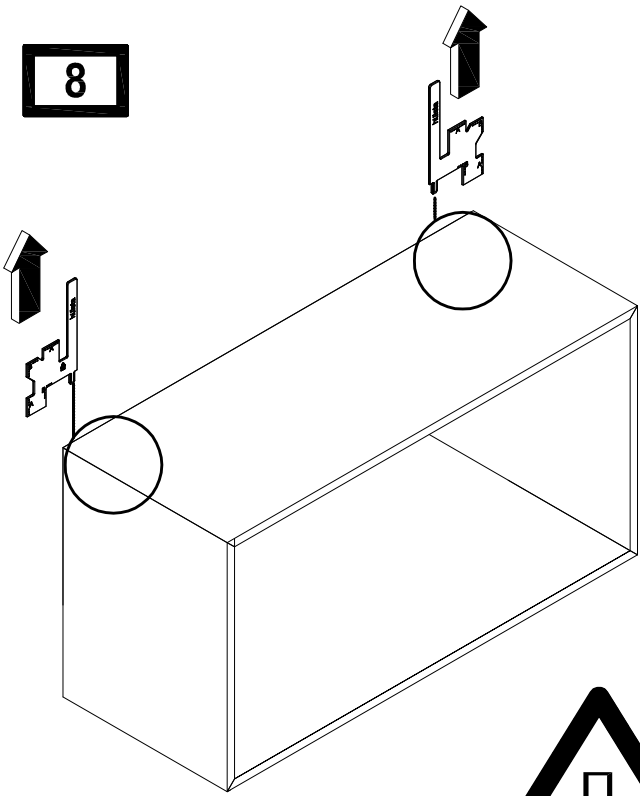

9

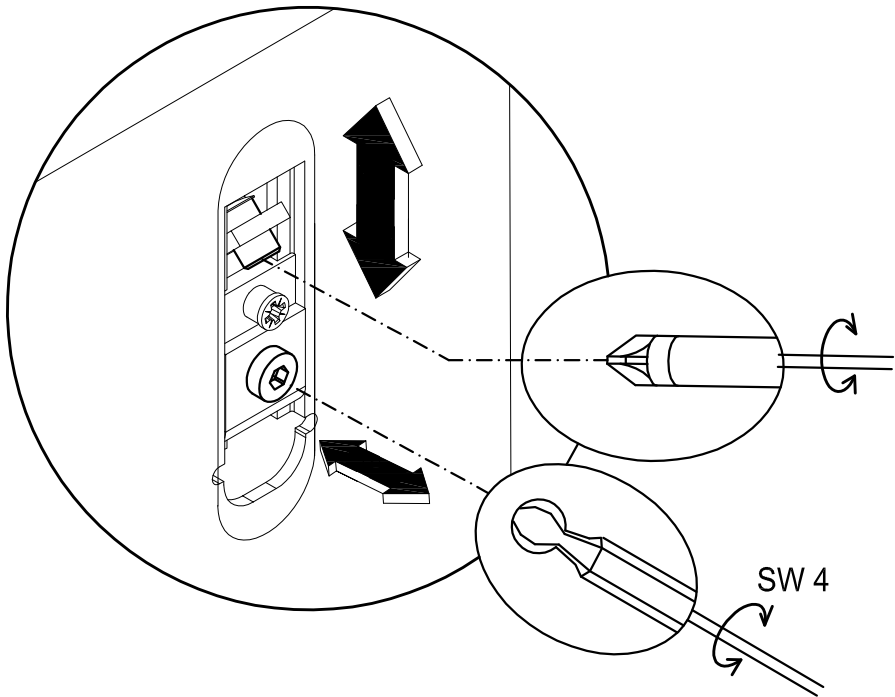

Hängeelement - Wandbefestigung Beschlag 807 XL

Wall unit - wall mounting bracket 807 XL

Element suspendu - Ferrure de montage mural 807 XL

Hängeelement - wandbevestigingsbeslag 807 XL

Position Wandbeschlag anhand des Korpusse bestimmen.

Determine position of wall bracket based on carcass.

Déterminer la position de la ferrure murale en fonction du corps.

Positie van de wandbevestiging aan hand van de elementromp bepalen.

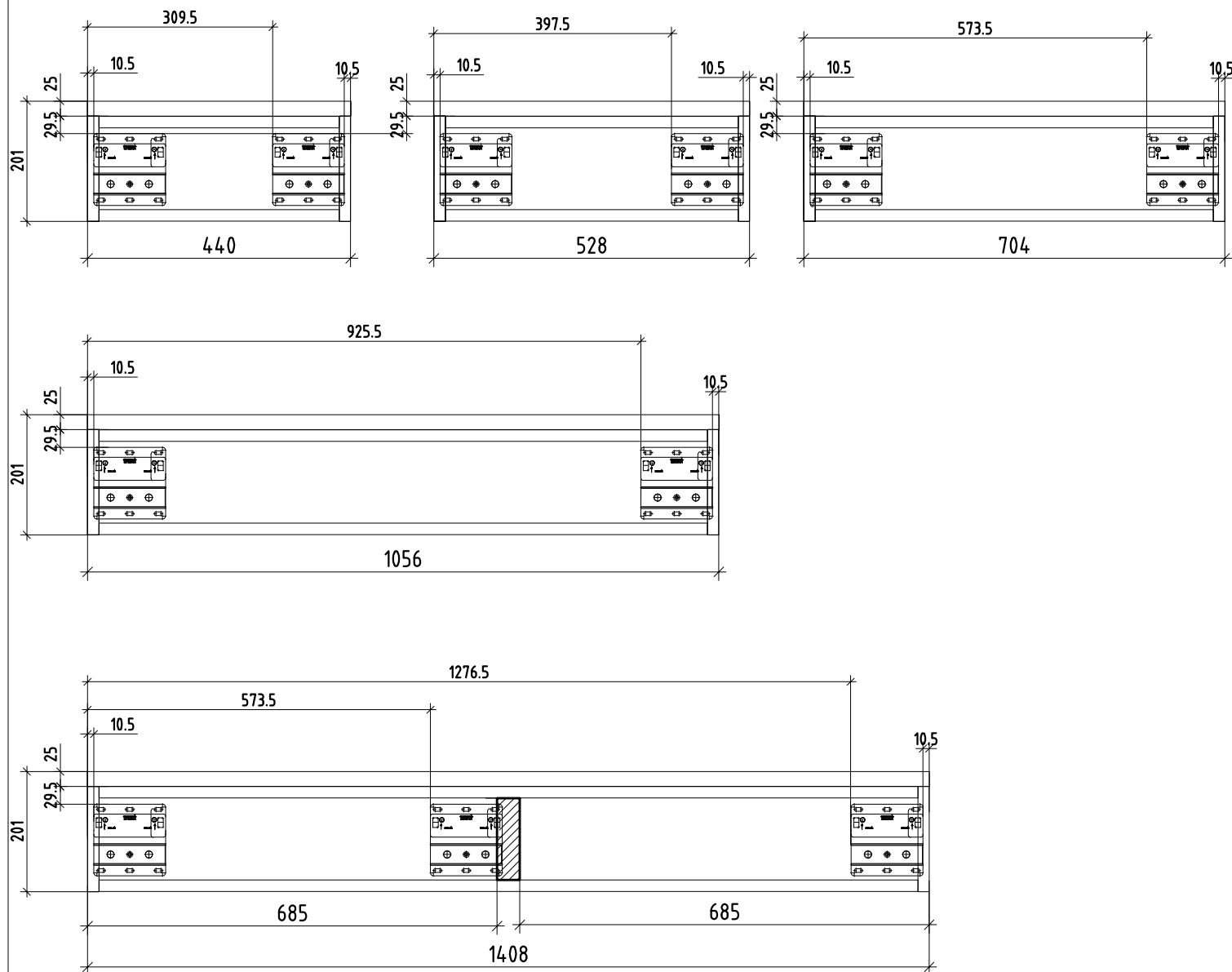
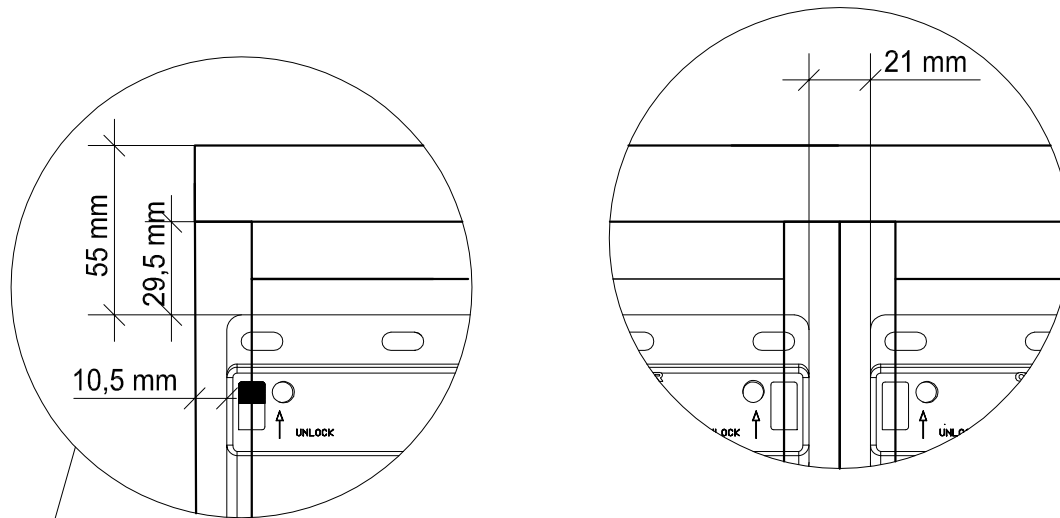

2

BB 2072
BB 2073

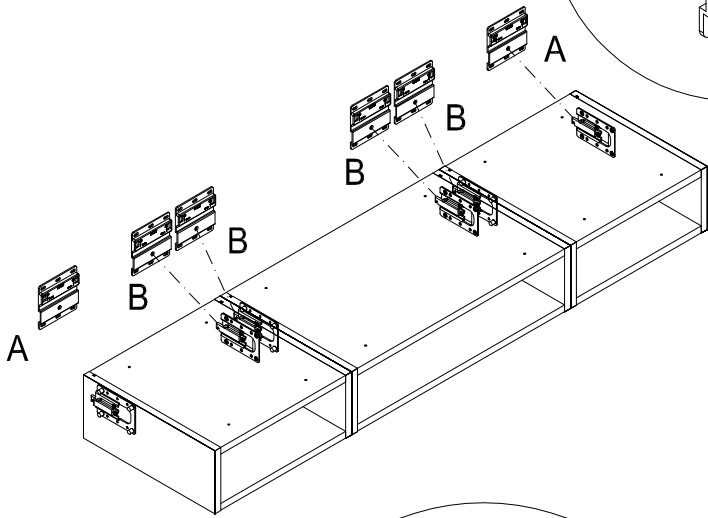
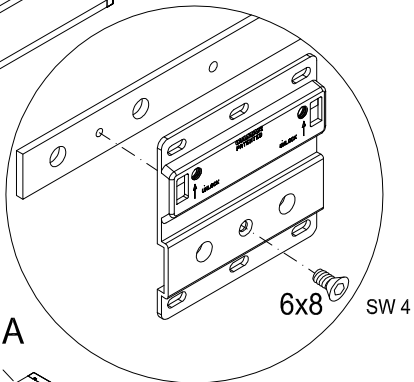
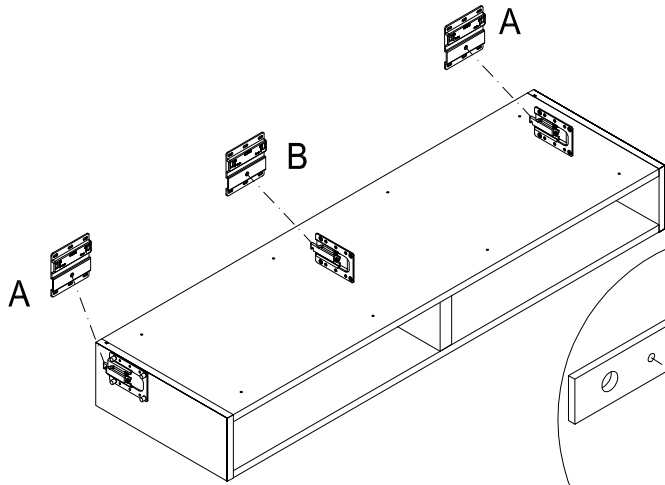
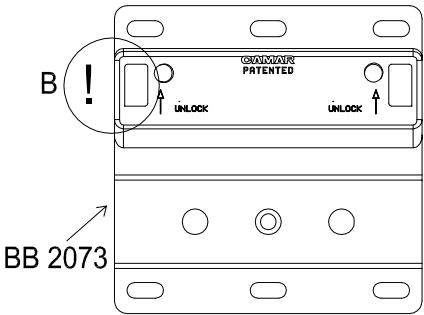
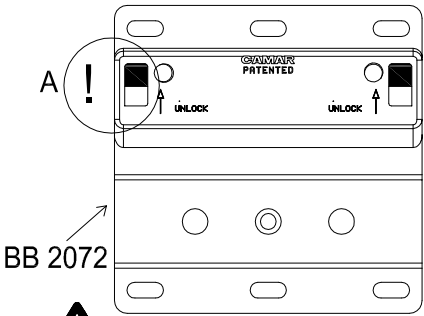
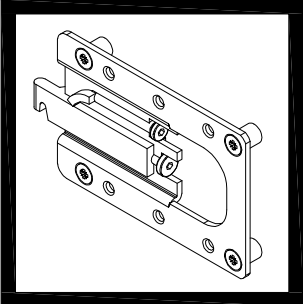

3

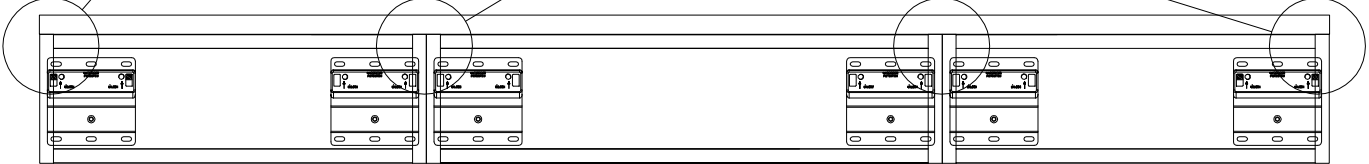
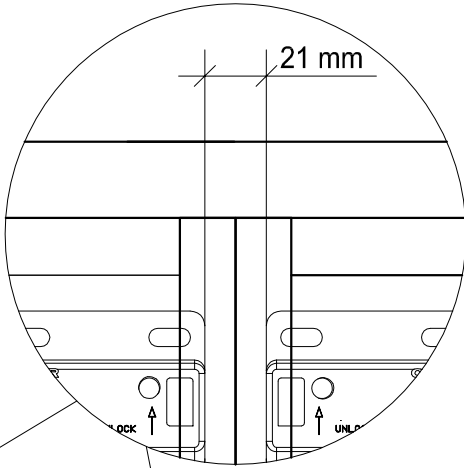
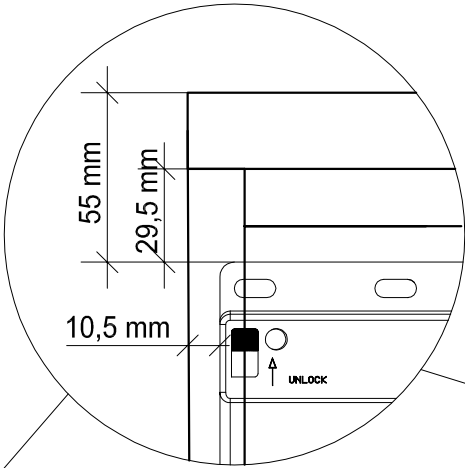

4

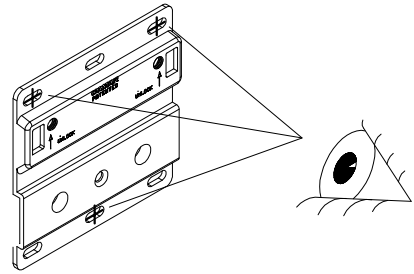
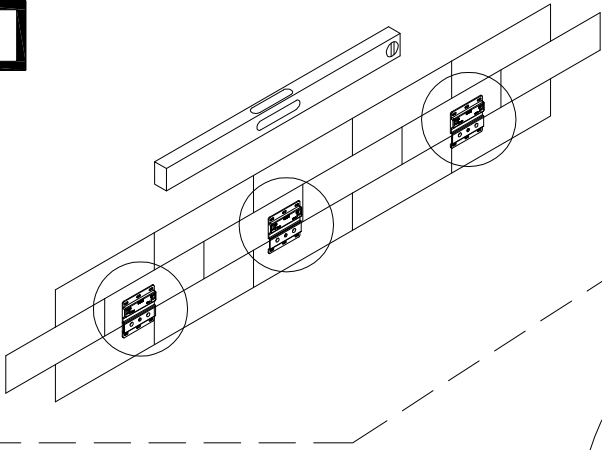

A

Befestigung mit Standard Set
 Assembly with standard set
 Montage avec set de standard
 montage met standaardset



BB 2460

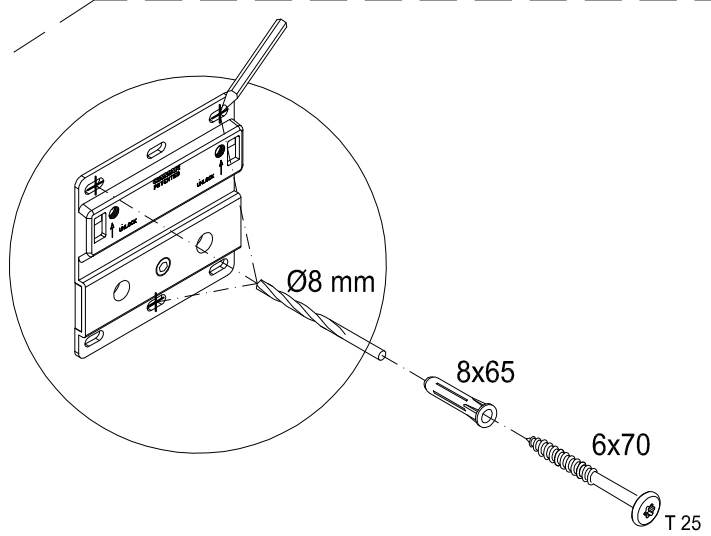

Ø8 mm

8x65

6x70

T 25

B

Befestigung mit Ankerhülse
 Assembly with anchor sleeve
 Montage avec manchon d'ancrage
 montage met ankerhulzen

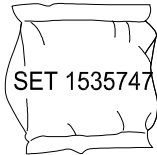

SET 1535747

SET	Mat. 1535747	
9x		FIS H 12x85 K
9x		FIS EK 6x75
1x		
2x		

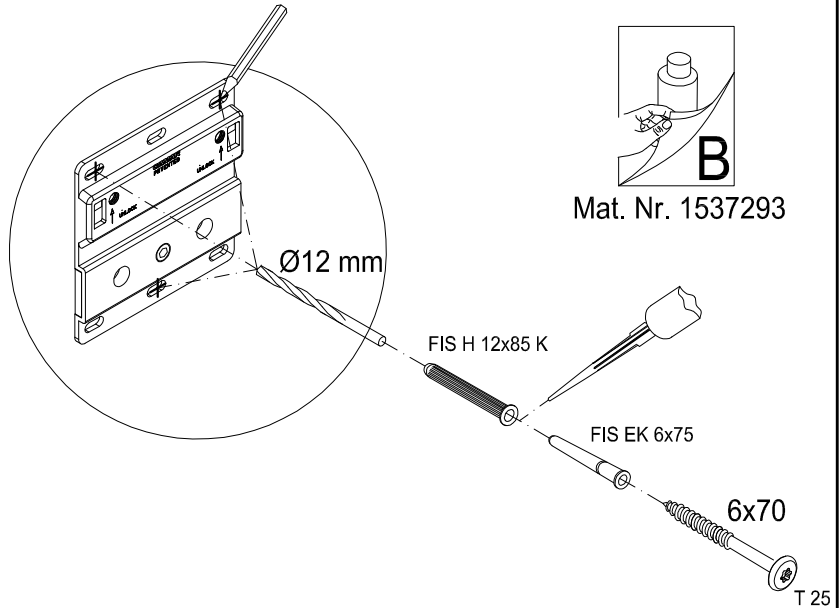

Ø12 mm

FIS H 12x85 K

FIS EK 6x75

6x70

T 25

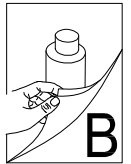

B

Mat. Nr. 1537293

C

Befestigung ohne Ankerhülse
 Assembly without anchor sleeve
 Montage sans manchon d'ancrage
 Montage zonder ankerhulzen

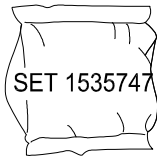

SET 1535747

SET	Mat. 1535747	
9x		FIS H 12x85 K
9x		FIS EK 6x75
1x		
2x		

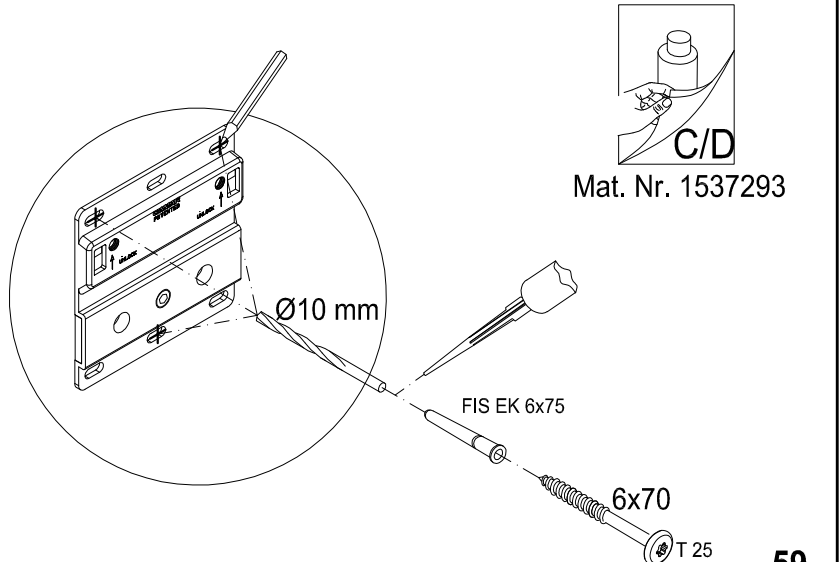

Ø10 mm

FIS EK 6x75

6x70

T 25

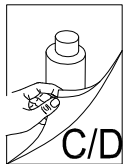

C/D

Mat. Nr. 1537293

5

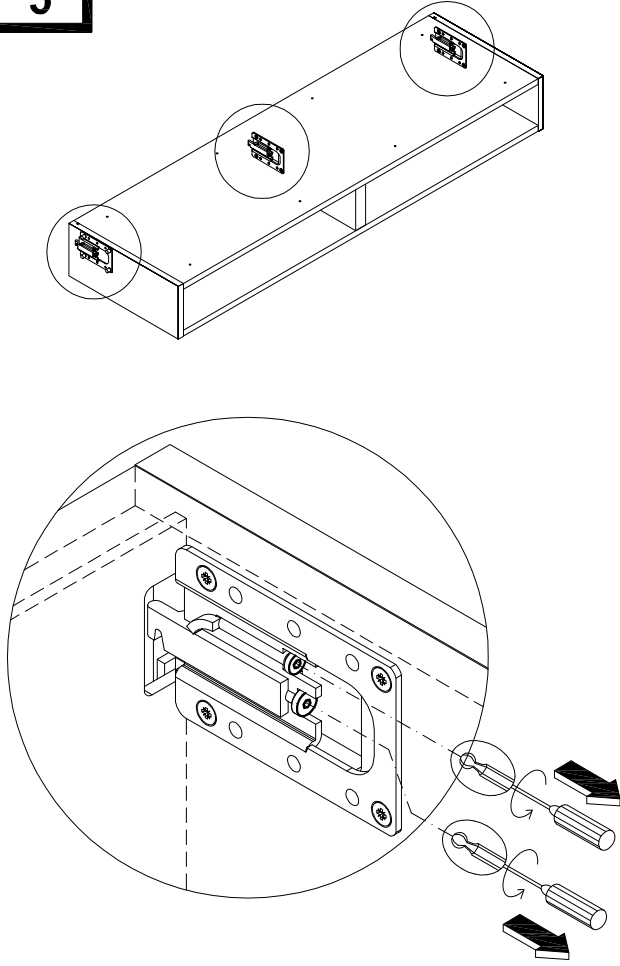

6

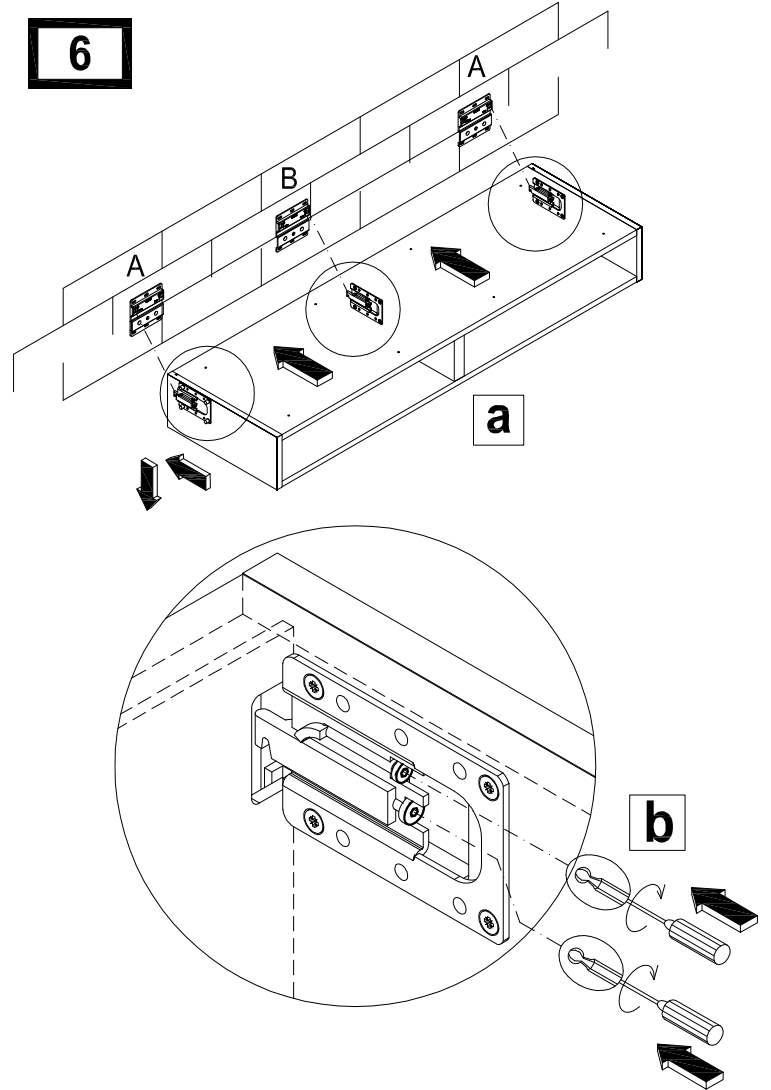

7

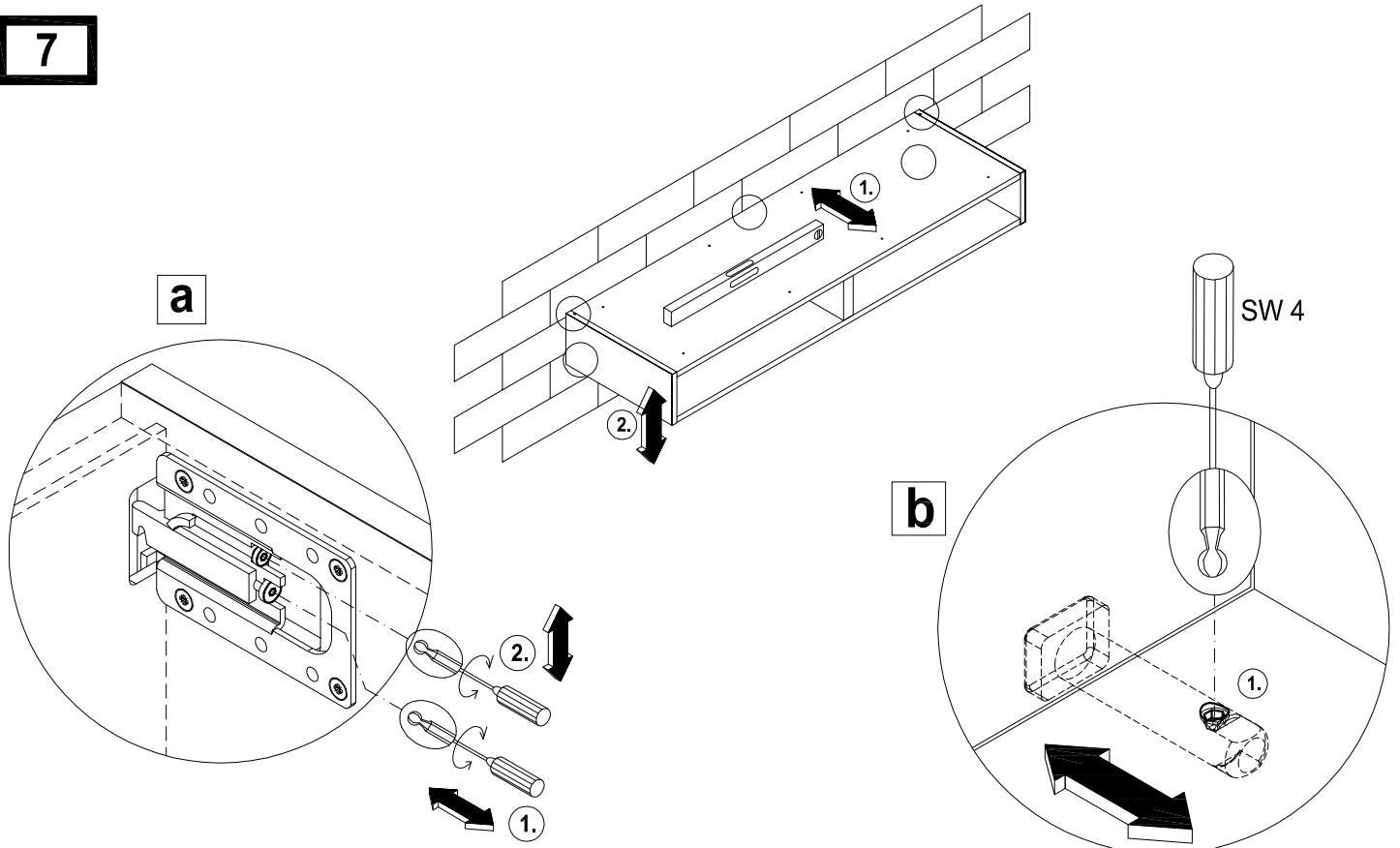

2

BB 2470

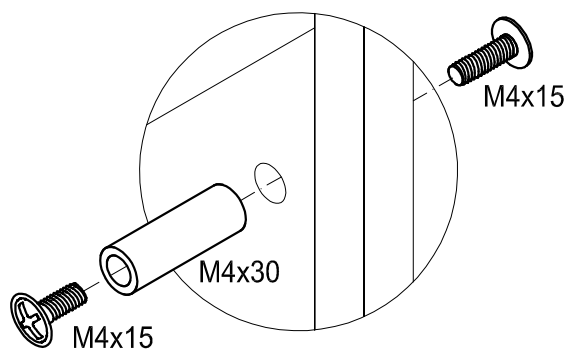
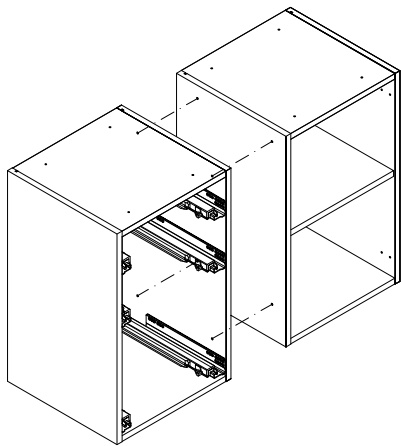

3

BB 1466

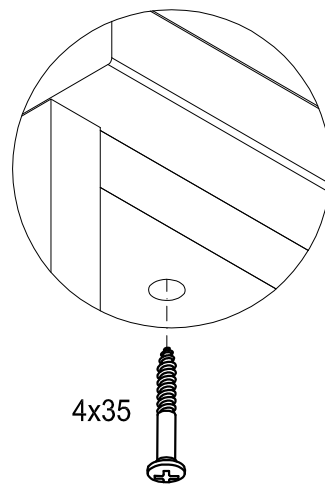
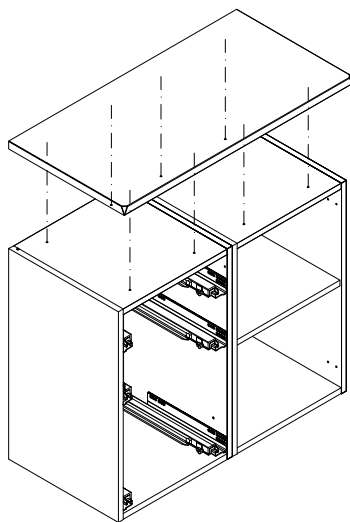

1

BB 2615
BB 2626

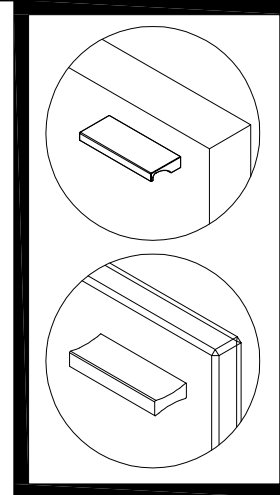
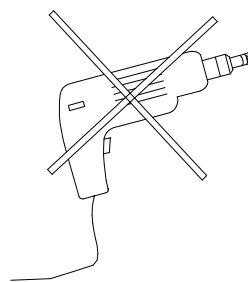
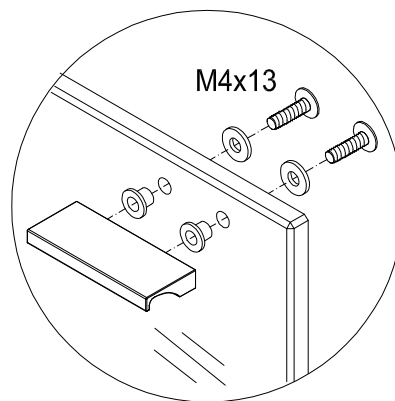
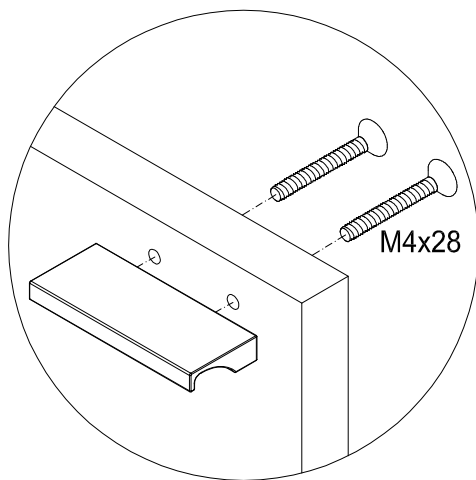

1

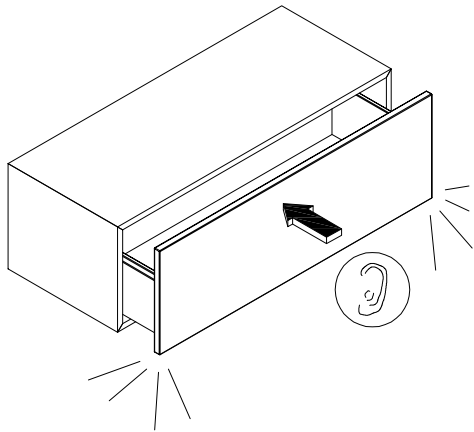

2

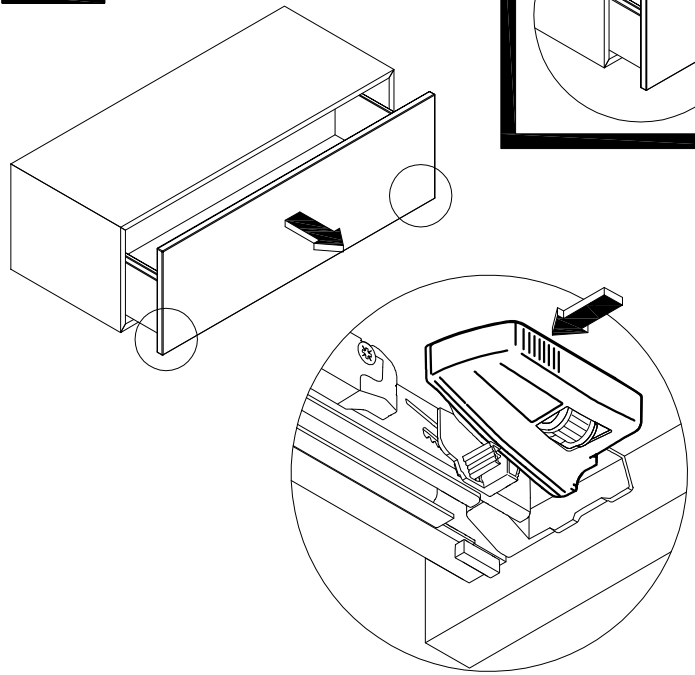

3

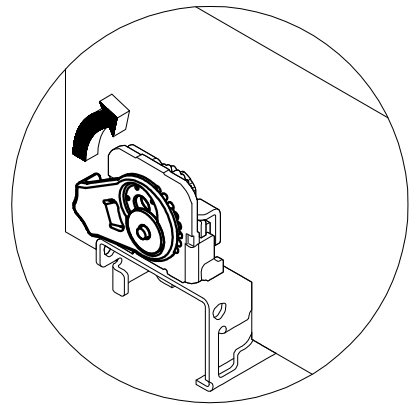
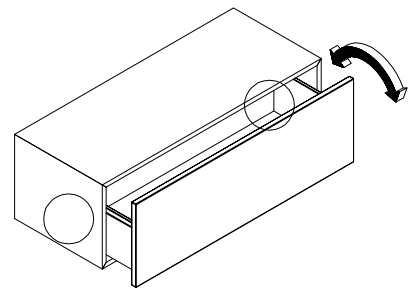
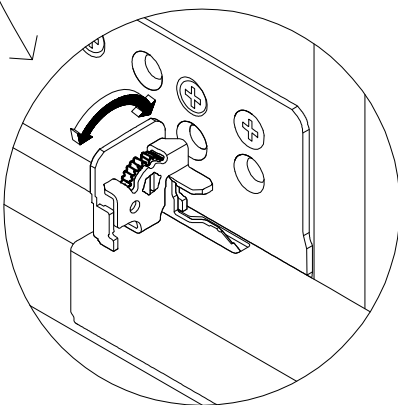
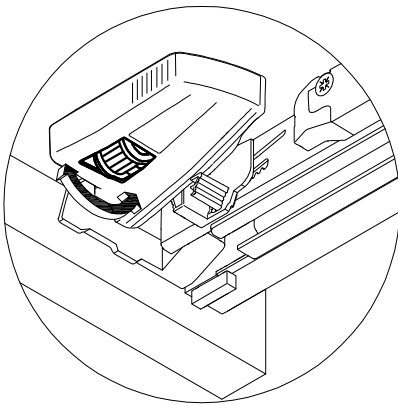
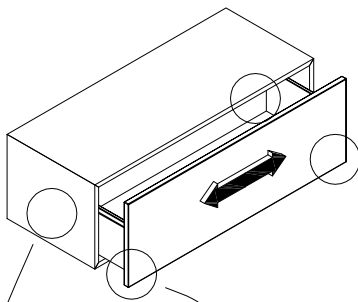
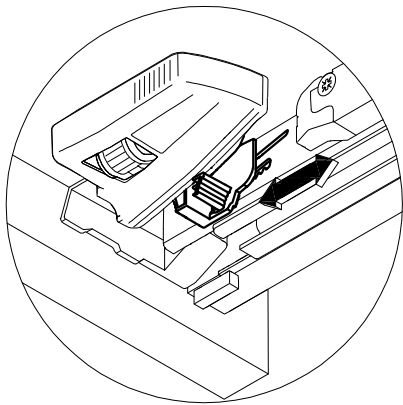
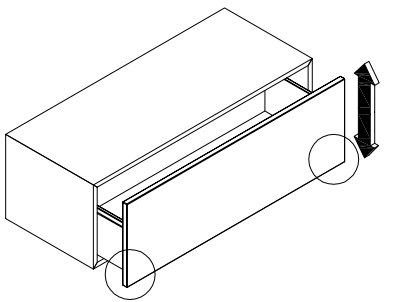

1

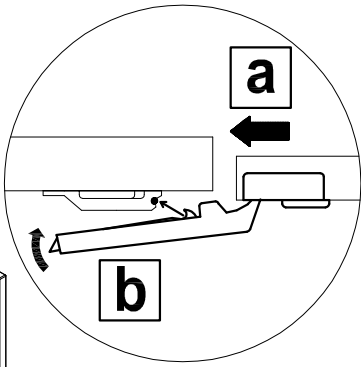
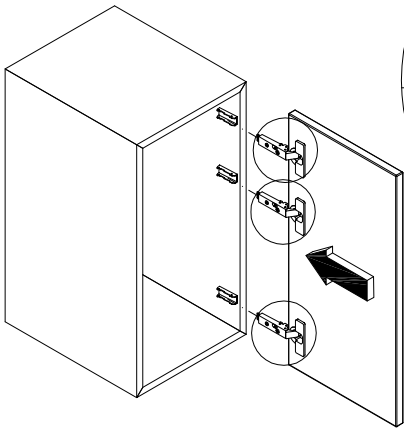

3

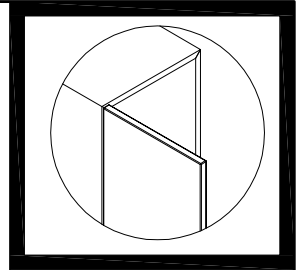
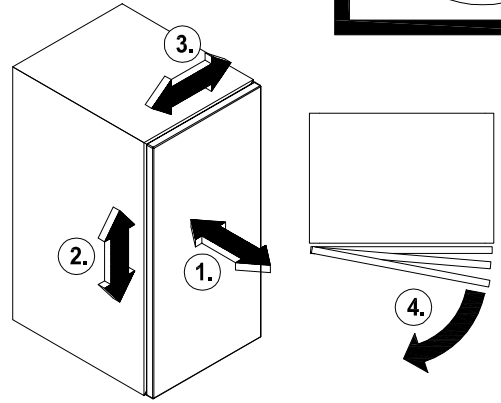

2

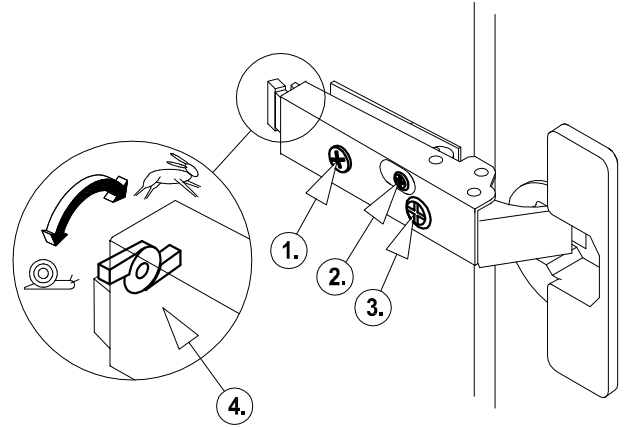
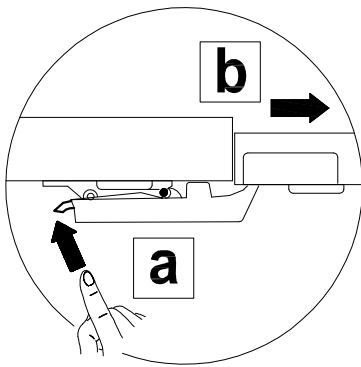
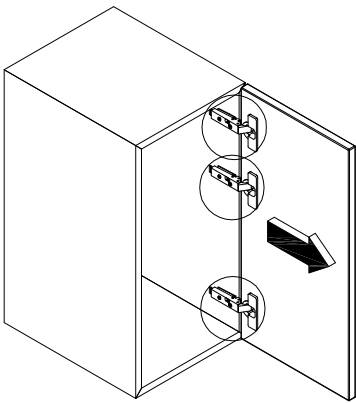

1

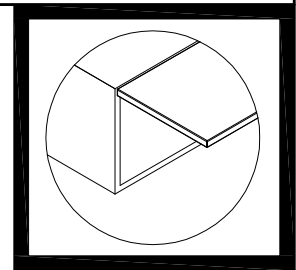
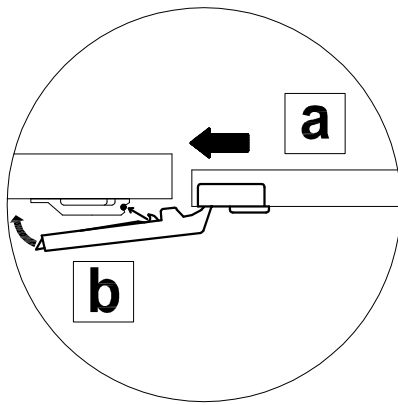
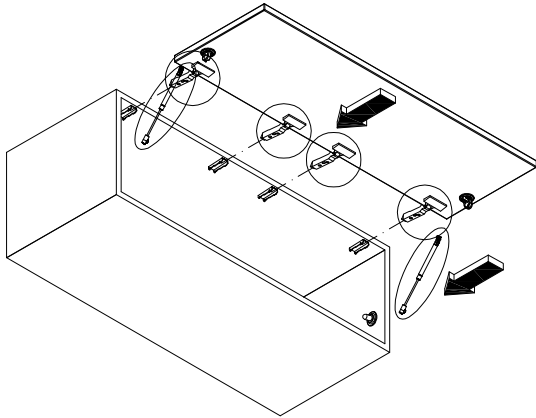

2

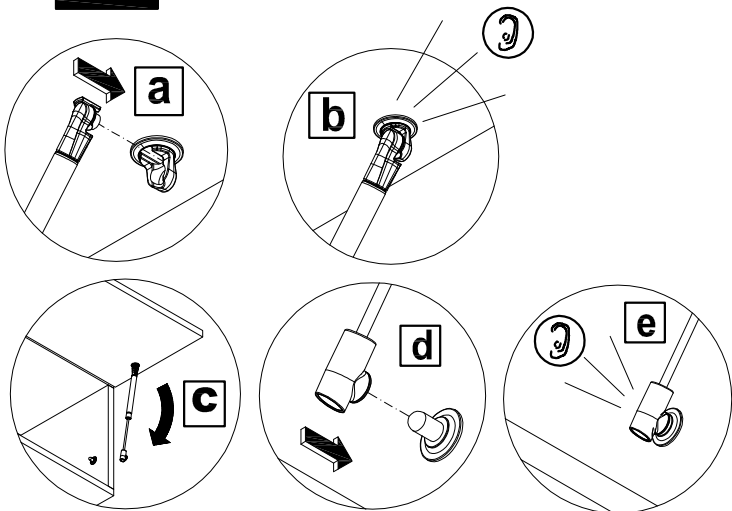

3

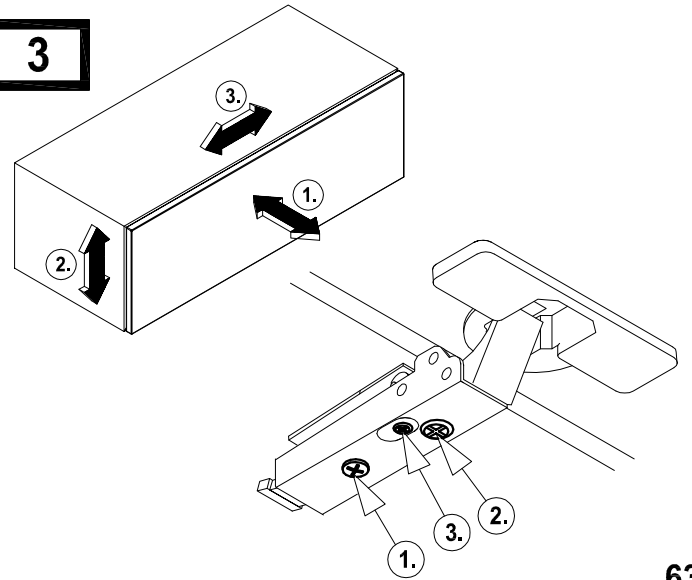

1

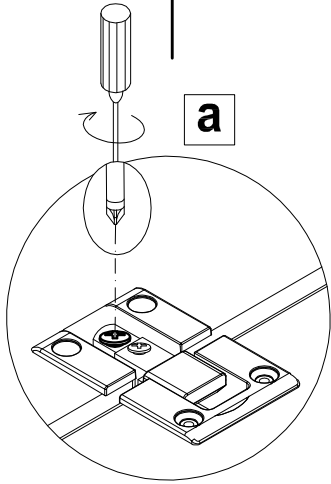
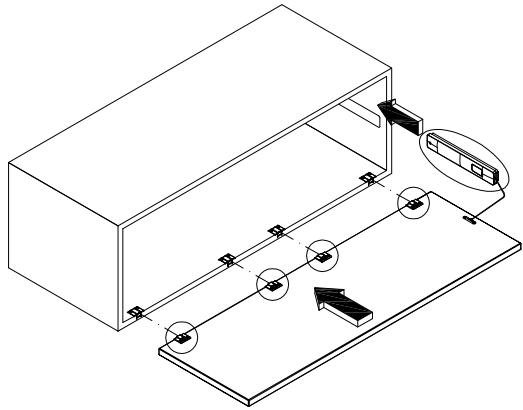
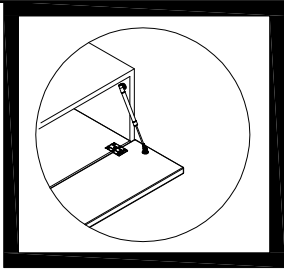
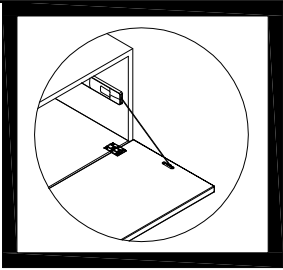

a

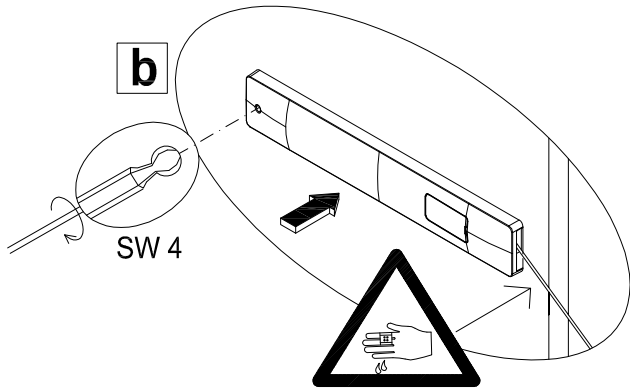
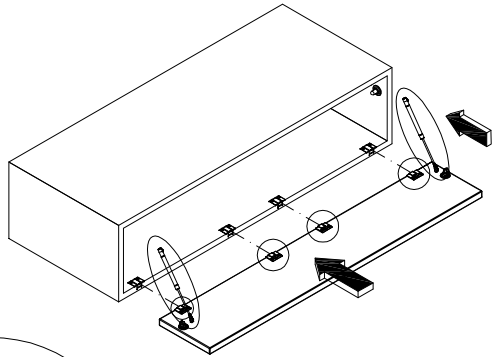

b

SW 4

Verletzungsgefahr, da das Sell unter einer großen Zugkraft steht.
Risk of injury as rope is under a lot pressure.
Danger de blessures, car le câble est sous une tension importante.
Blessuregevaar, op de kabel staat een grote trekkracht.

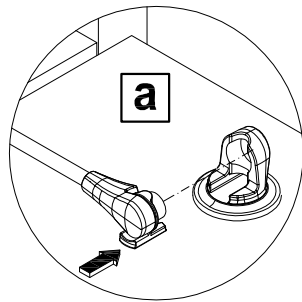

a

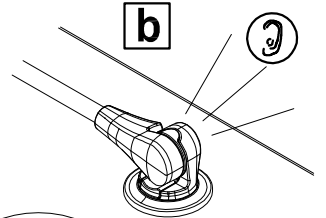

b

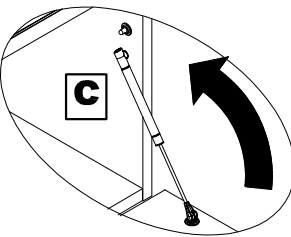

c

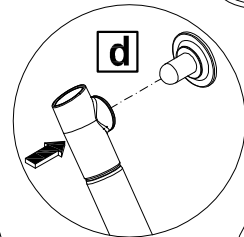

d

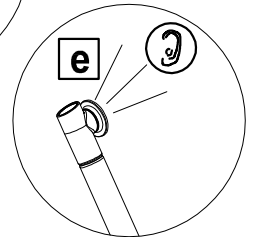

e

2

