

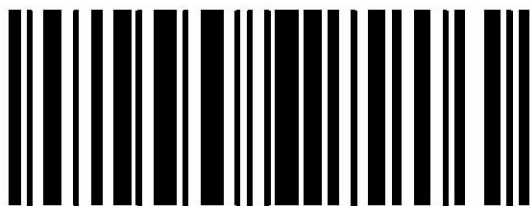

Montageanleitung

Esstisch 160er & 190er
Dining table
Table pour repas
Ettafel

now!
by hülsta

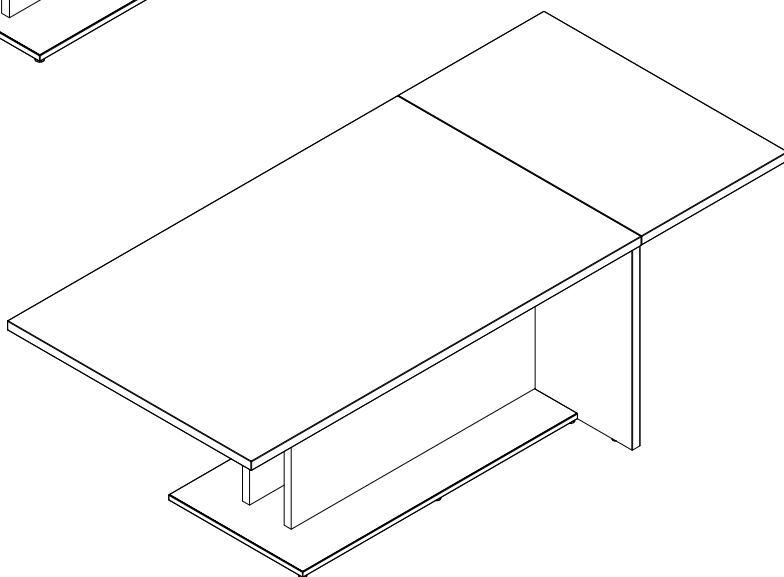
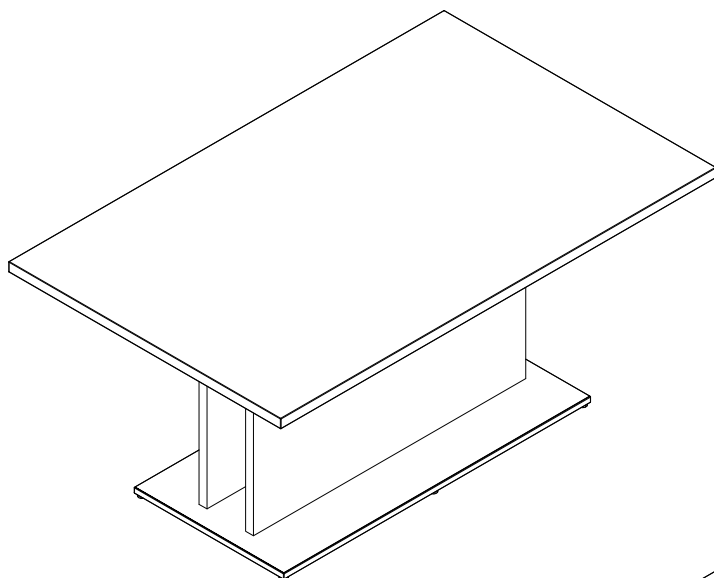

1484874

Lesen Sie zuerst die Anleitung
und beginnen Sie dann mit der Montage.

Before starting with the fitting, please read carefully the fitting instruction.

Avant de commencer avec le montage, nous vous prions de bien lire le notice de montage.

Voordat uw met de montage begint, a.u.b. de montagehandleiding lezen.

hülsta-werke, D-48703 Stadtlohn
Tel ++49(0)2563/86-1500
Internet <http://www.now-by-huelsta.com>

Mat.-Nr: 1484874

Service

Karl-Hüls-Strasse 1
FAX ++49 (0)2563/86-1767
e-mail: info@huelsta.com

Stand: 11/2014

Inhalt:

Esstisch starr - Fixed dining table- *Table repas fixe* - Vaste eettafel

2-6

Esstisch ausziehbar - Pull-out dining-table - *Table pour repas extensible* - Uittrekbaar eettafel

7-19

Esstisch starr
Fixed dining table
Table repas fixe
Vaste eettafel

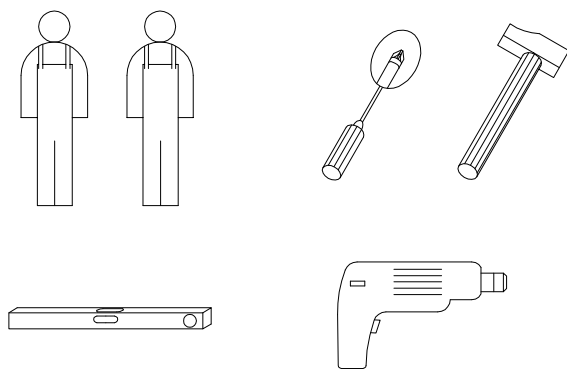
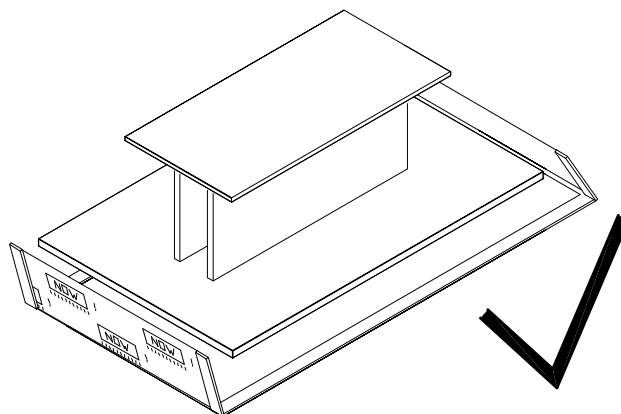
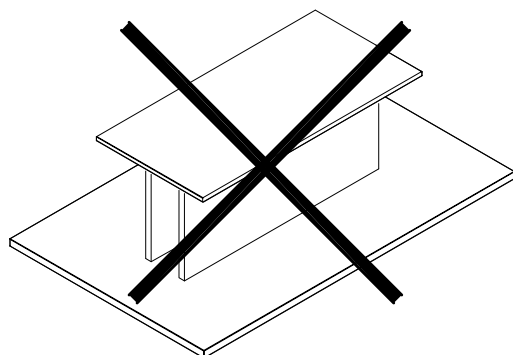

Verehrter Kunde, hier haben Sie die Möglichkeit die mitgelieferten Schrauben nachzumessen.

Dear customer, here you find a possibility to measure the delivered screws!

Cher client, ici vous avez la possibilité de mesurer les vis livrées!









Beste klant, hier heeft uw de mogelijkheid de schroeven te meten!



BK now! dining ET

Mat.-Nr.: 1484884

BK now! time * BK now! time * BK now! time

F	 6x 1127222	J	 8x 4x45 1014148
G	 16x 7-70 276034	K	 2x 1218488
H	 1x SW 4 410351	L	 2x 1218489
I	 4x 5-30 1175714	M	 4x 3,5x17 121199
		N	 1x SW4 1484897

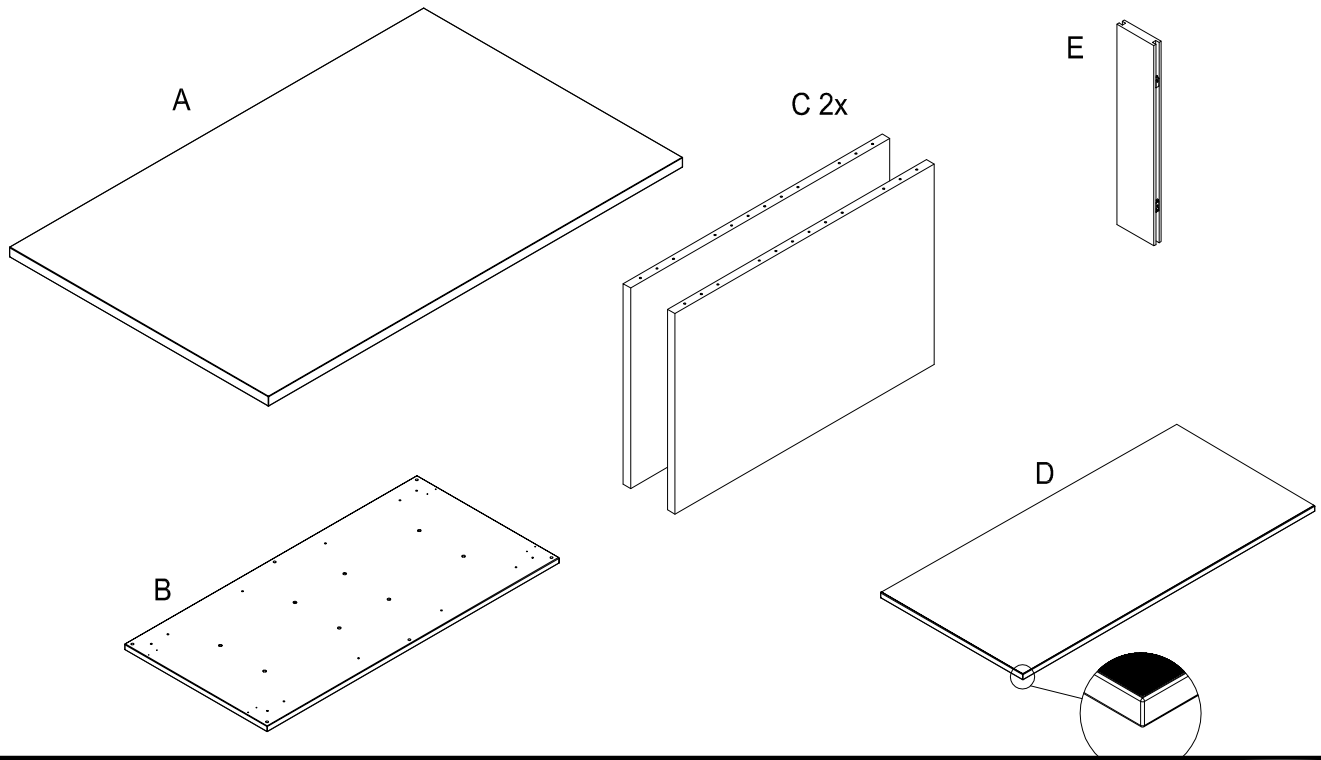

1

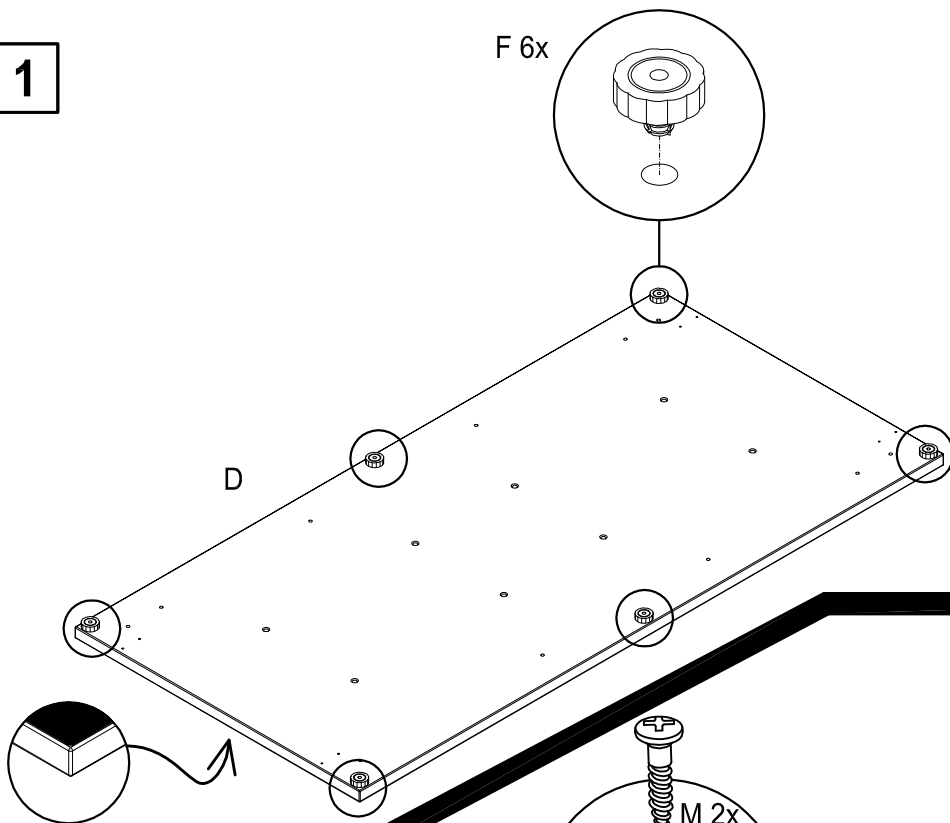

2

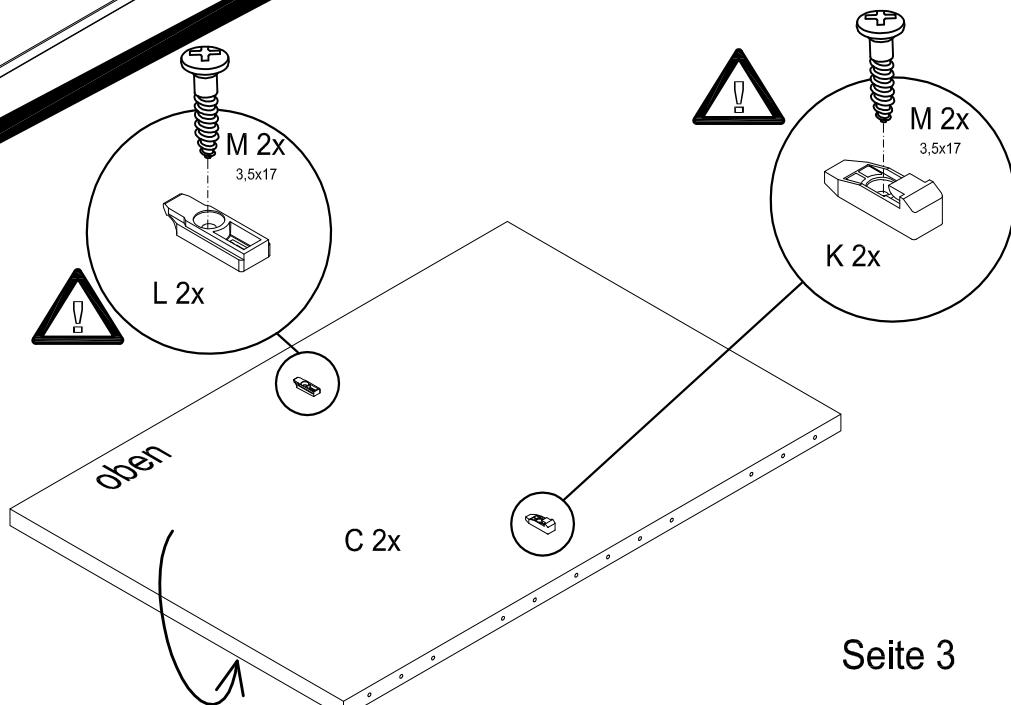

3

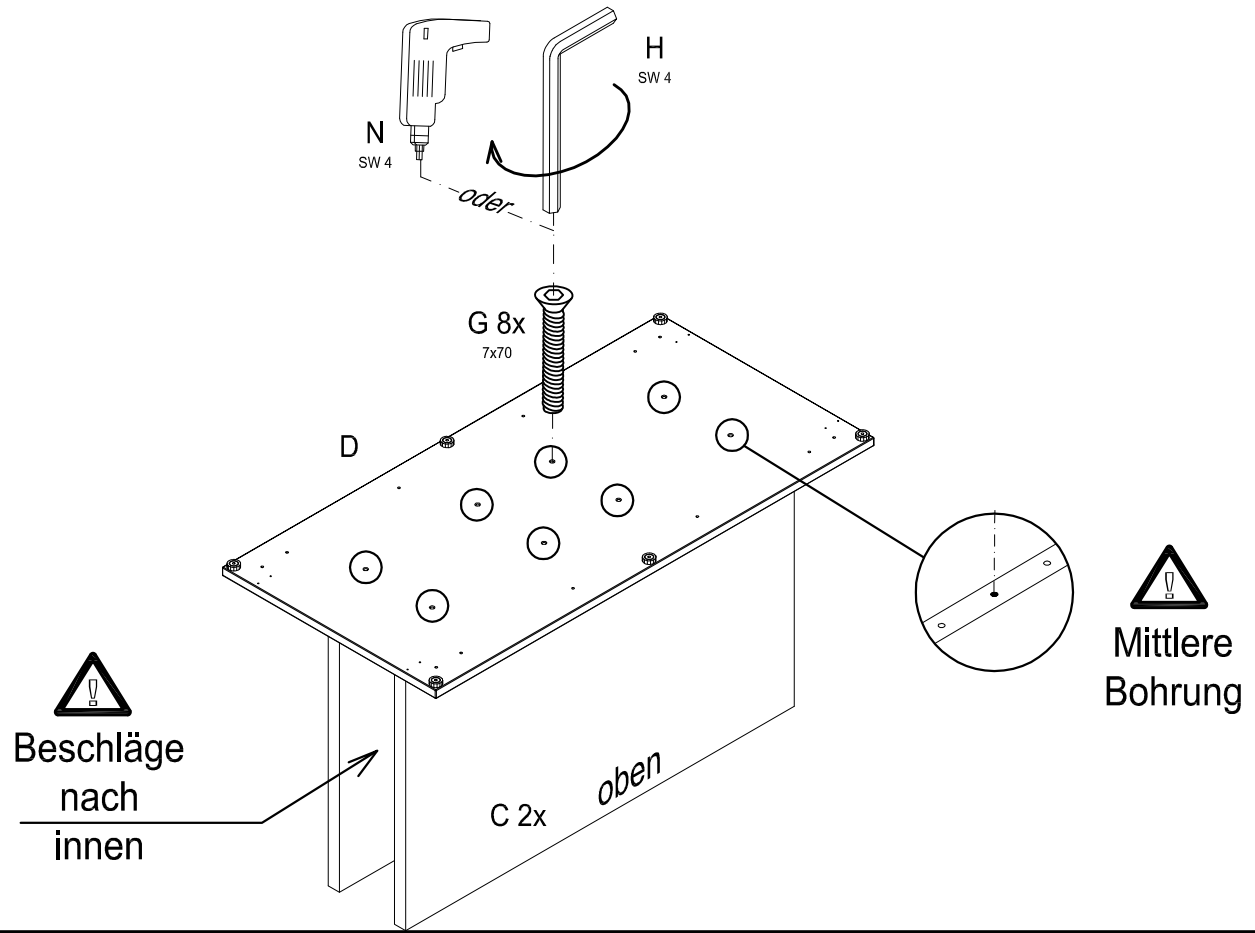

4

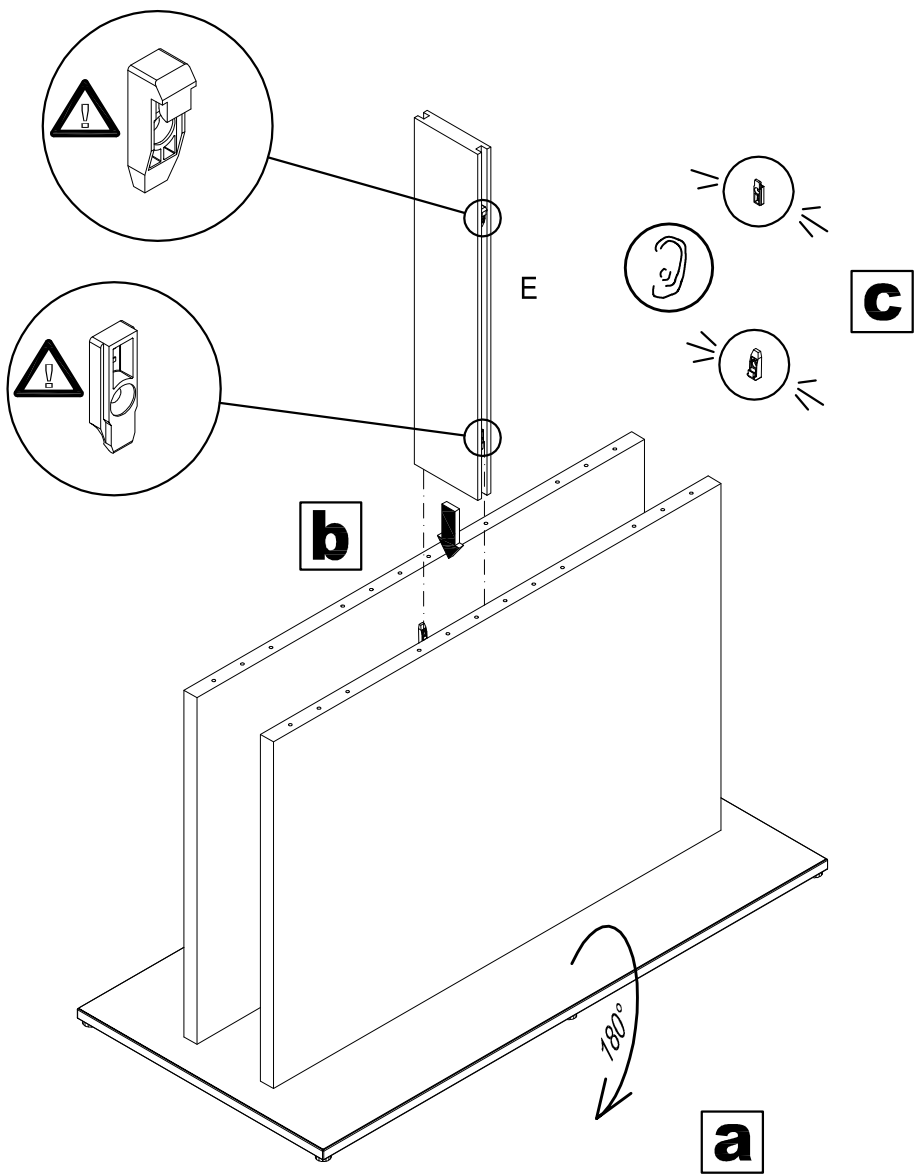

5

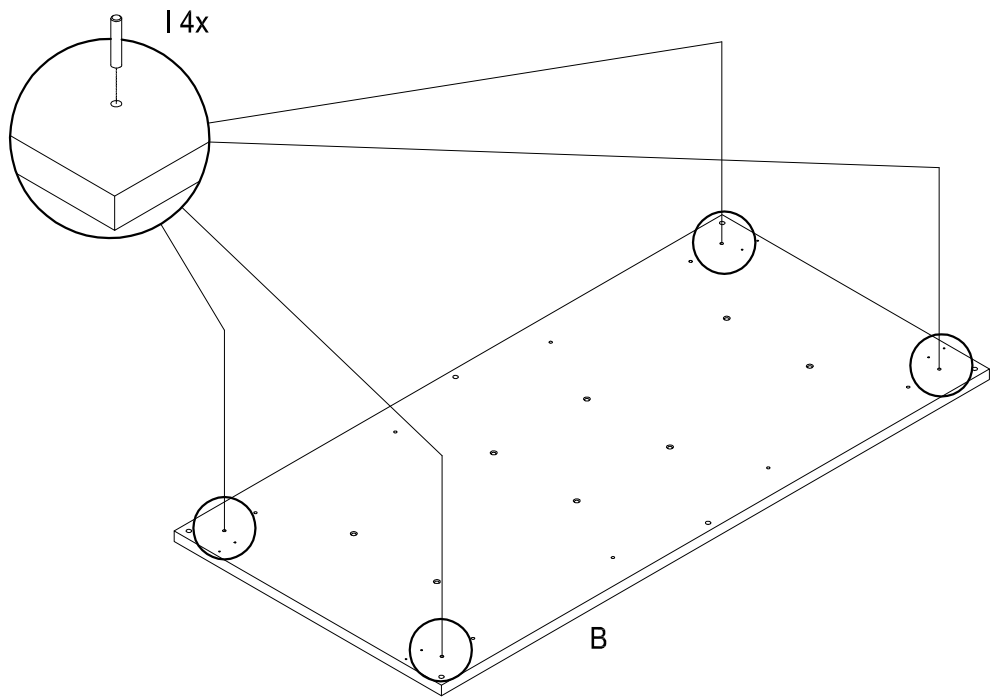

6

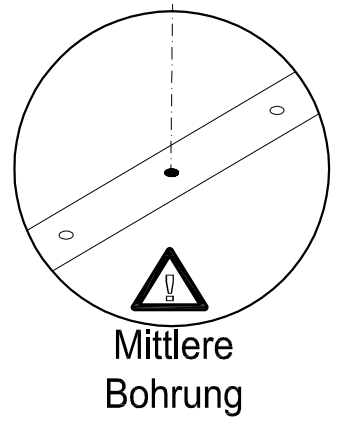
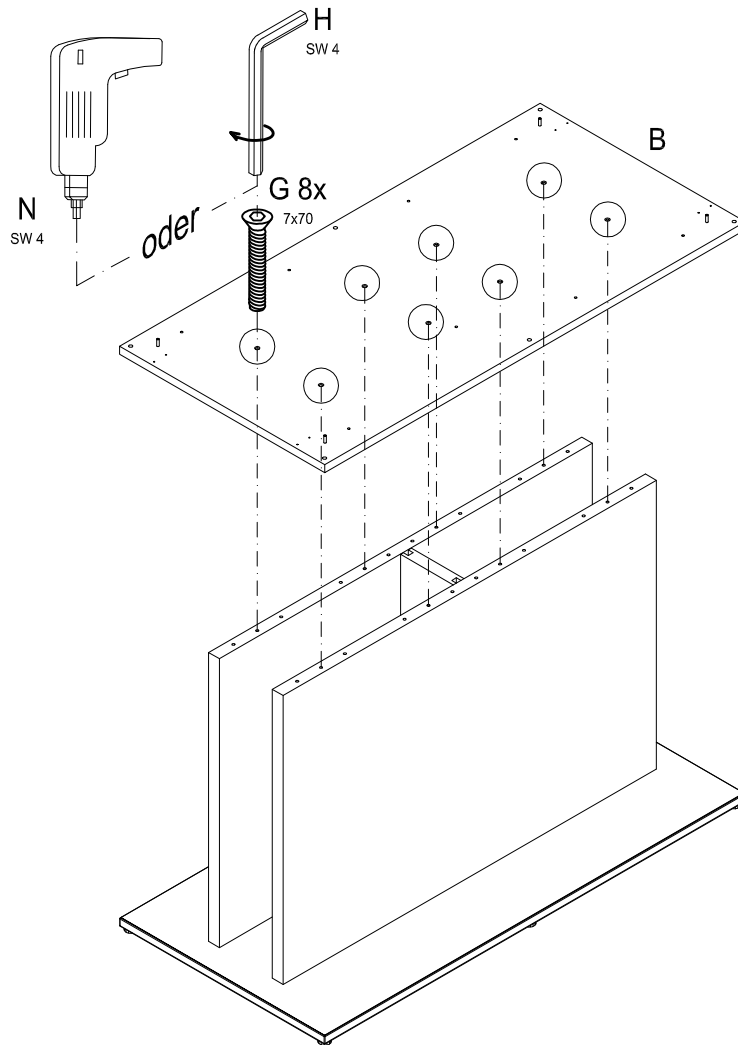

7

a

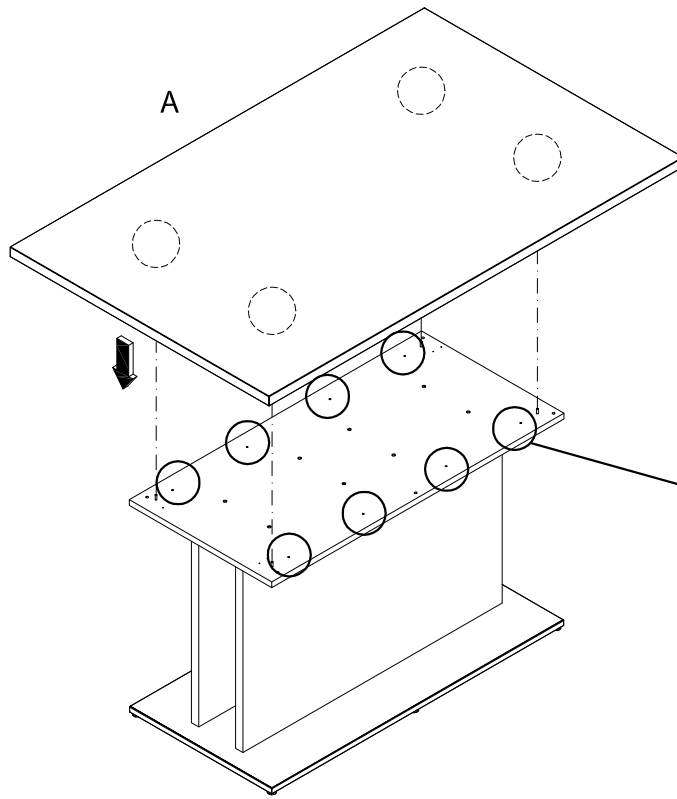
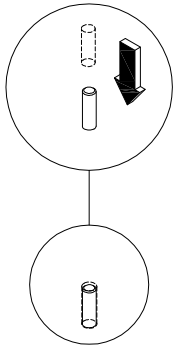

b

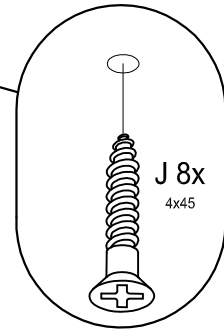

8

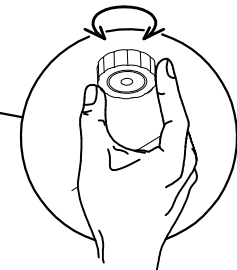
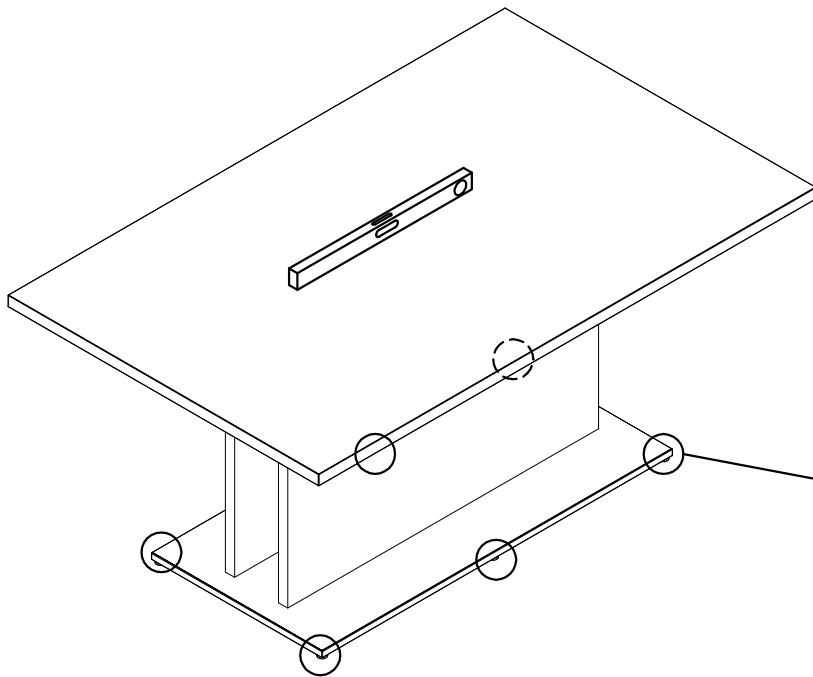



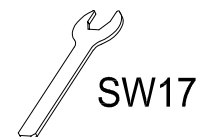
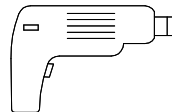
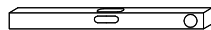
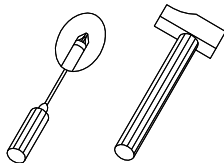
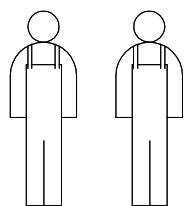





Esstisch ausziehbar
 Pull-out dining-table
 Table pour repas extensible
 Uittrekbaar eettafel



BK now! dining ET

Mat.-Nr.: 1484884















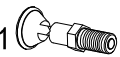

BK now! time * BK now! time * BK now! time

F  6x 1127222	J  8x 4x45 1014148
G  16x 7-70 276034	K  2x 1218488
H  1x SW 4 410351	L  2x 1218489
I  4x 5-30 1175714	M  4x 3,5x17 121199
	N  1x SW4 1484897

BK now! dining ET Anlegeplatte

Mat.-Nr.: 1484885

BK now! time * BK now! time * BK now! time

F  2x 1127222	Z  10x 3x17 886203	F1  2x 1265853 - Natureiche 1248475 - Kernussbaum 1486393 - Lack weiß
U  2x 1484907	A1  4x 1484898	G1  1x SW6 46626
V  4x 4x20 275832	B1  8x 4x45 79248	H1  2x 1484899
W  1x 641391	C1  2x 588798	J1  4x 4x70 359563
X  1x 682784	D1  2x 1162846	
M  6x 3,5x17 121199	E1  2x 1186123	

Verehrter Kunde, hier haben Sie die Möglichkeit die mitgelieferten Schrauben nachzumessen.

Dear customer, here you find a possibility to measure the delivered screws!

Cher client, ici vous avez la possibilité de mesurer les vis livrées!

Beste klant, hier heeft uw de mogelijkheid de schoeven te meten!



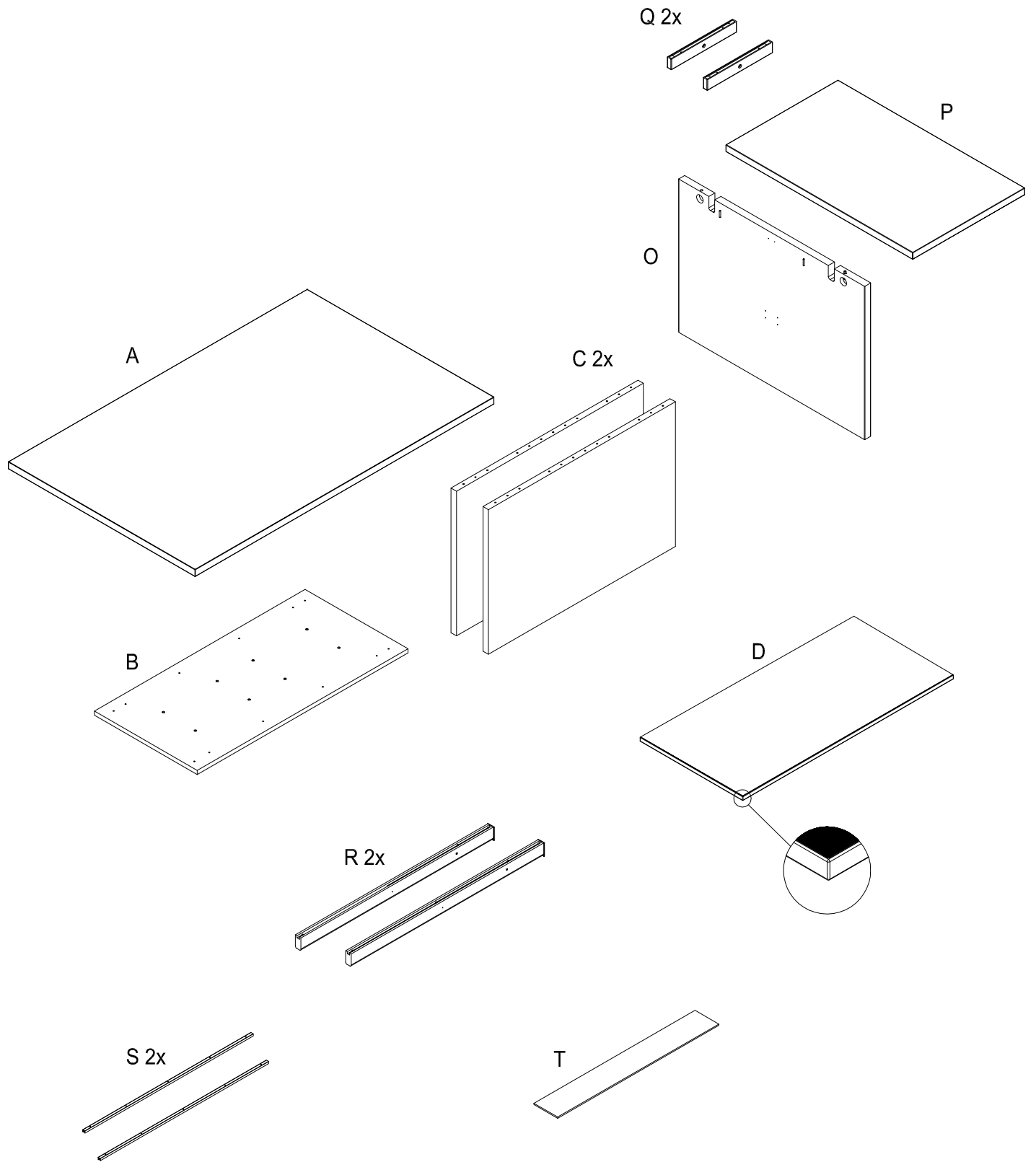

1

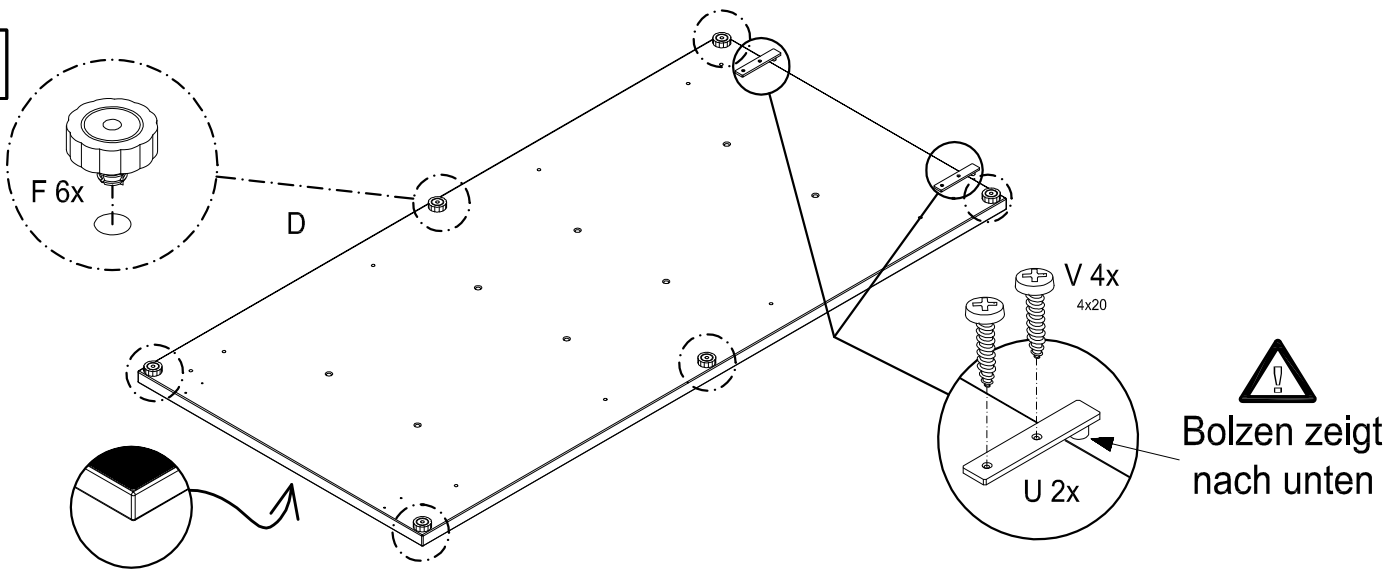

2

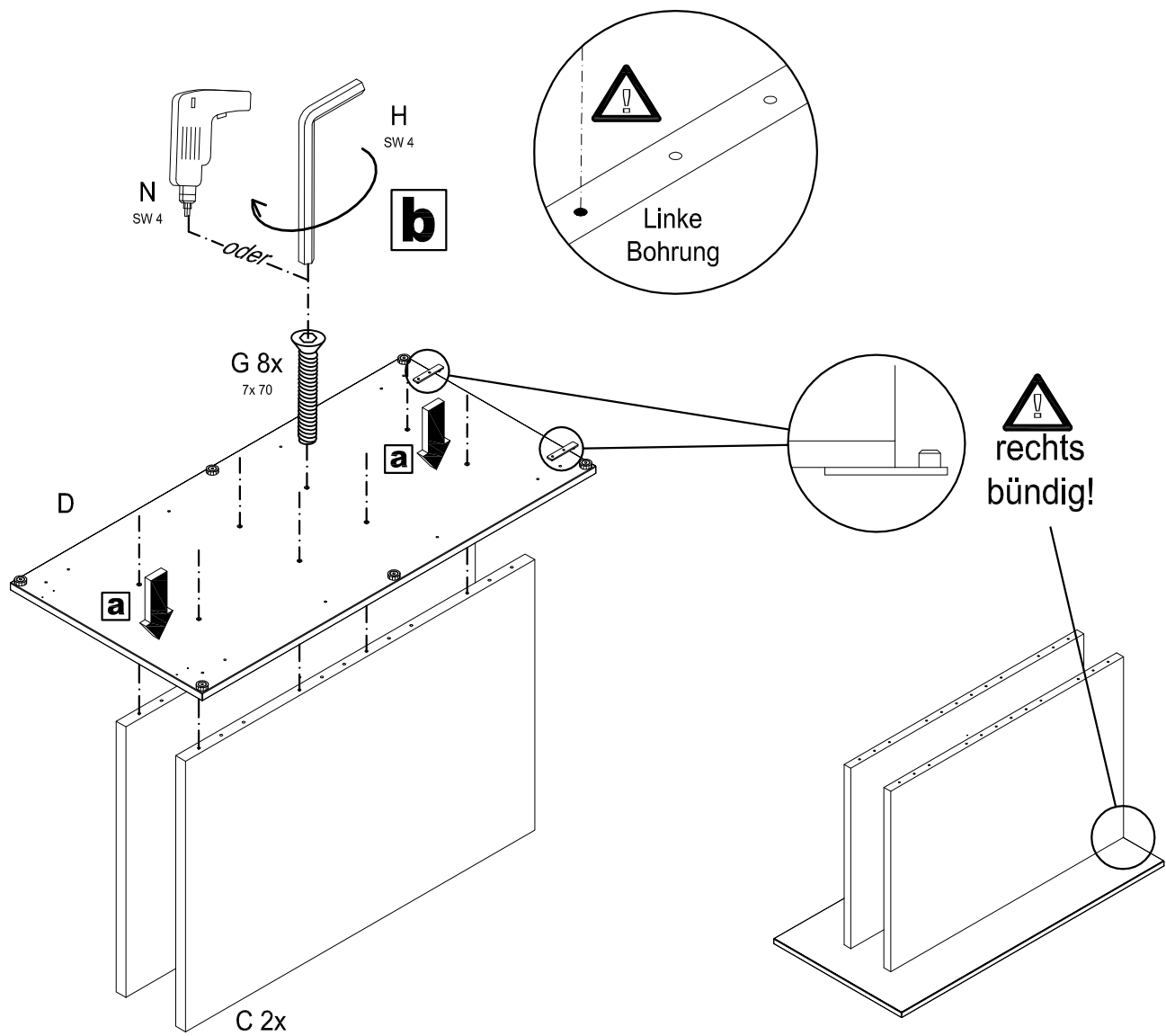

3

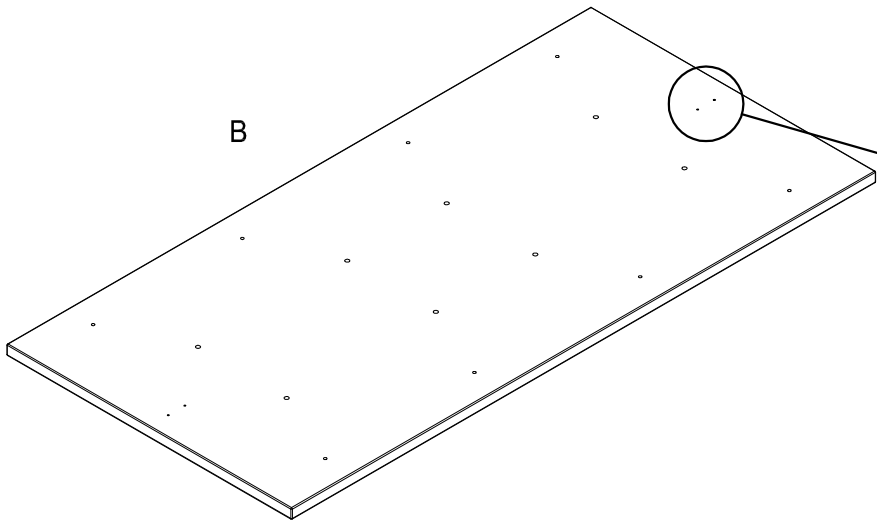

M 2x
3,5x17

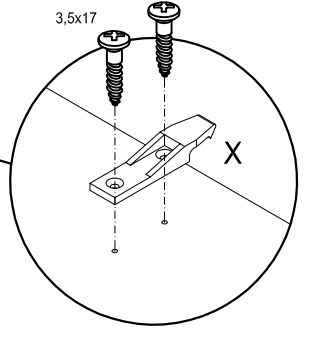

4

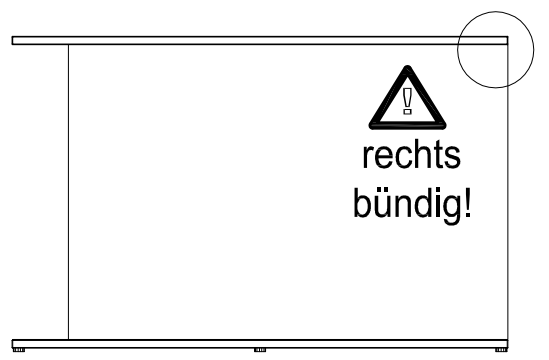
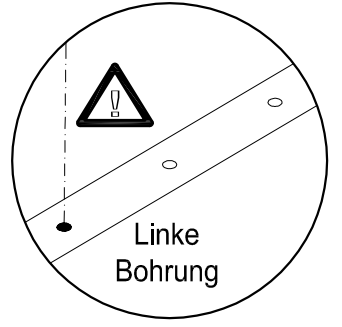
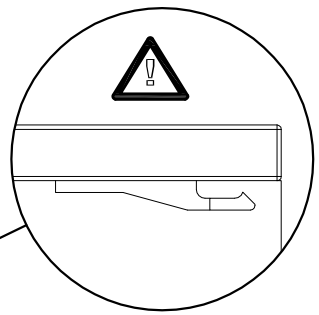
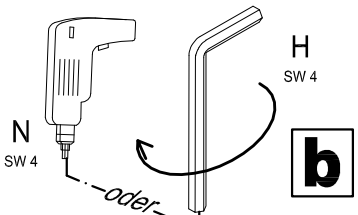
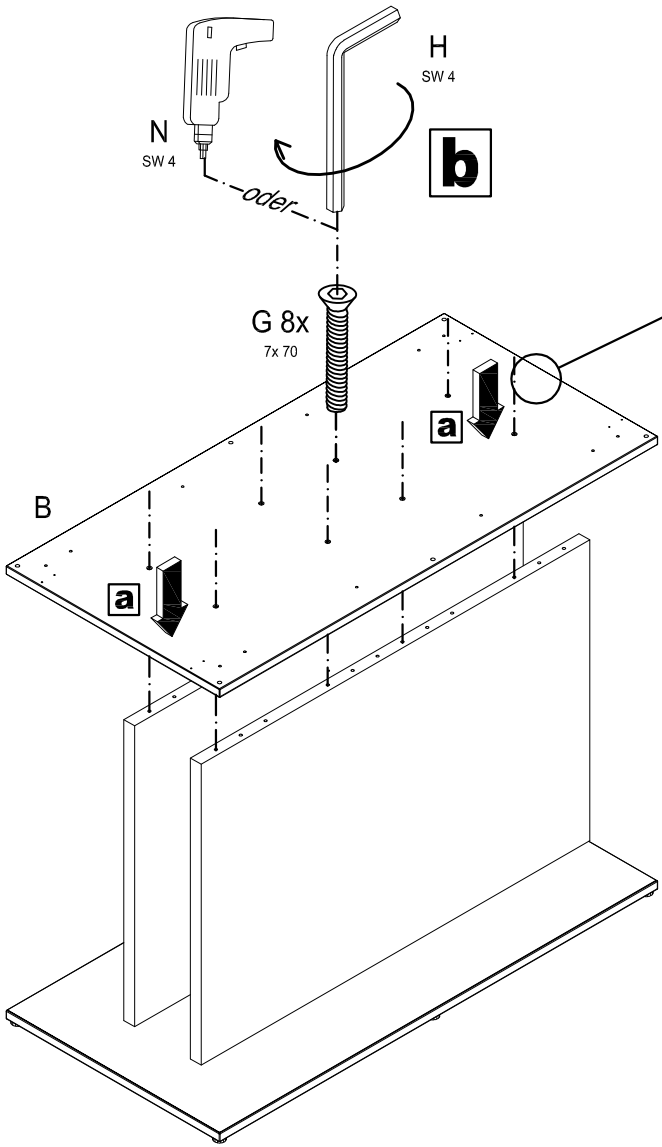

5

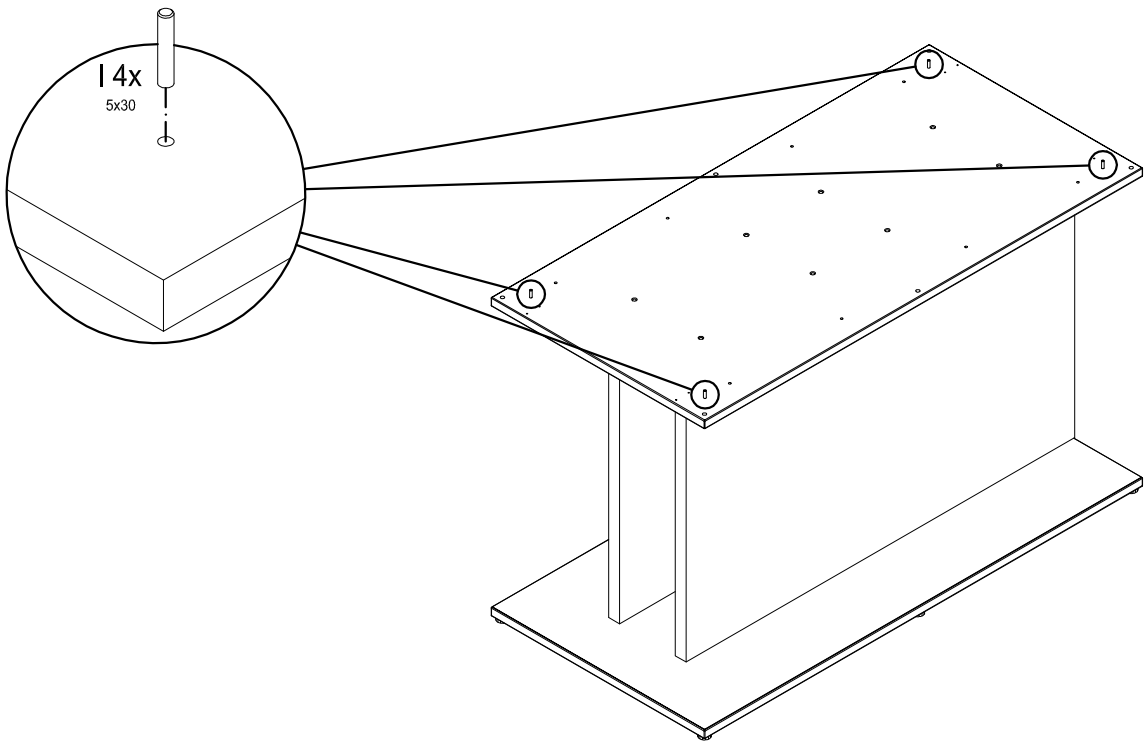

6

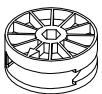
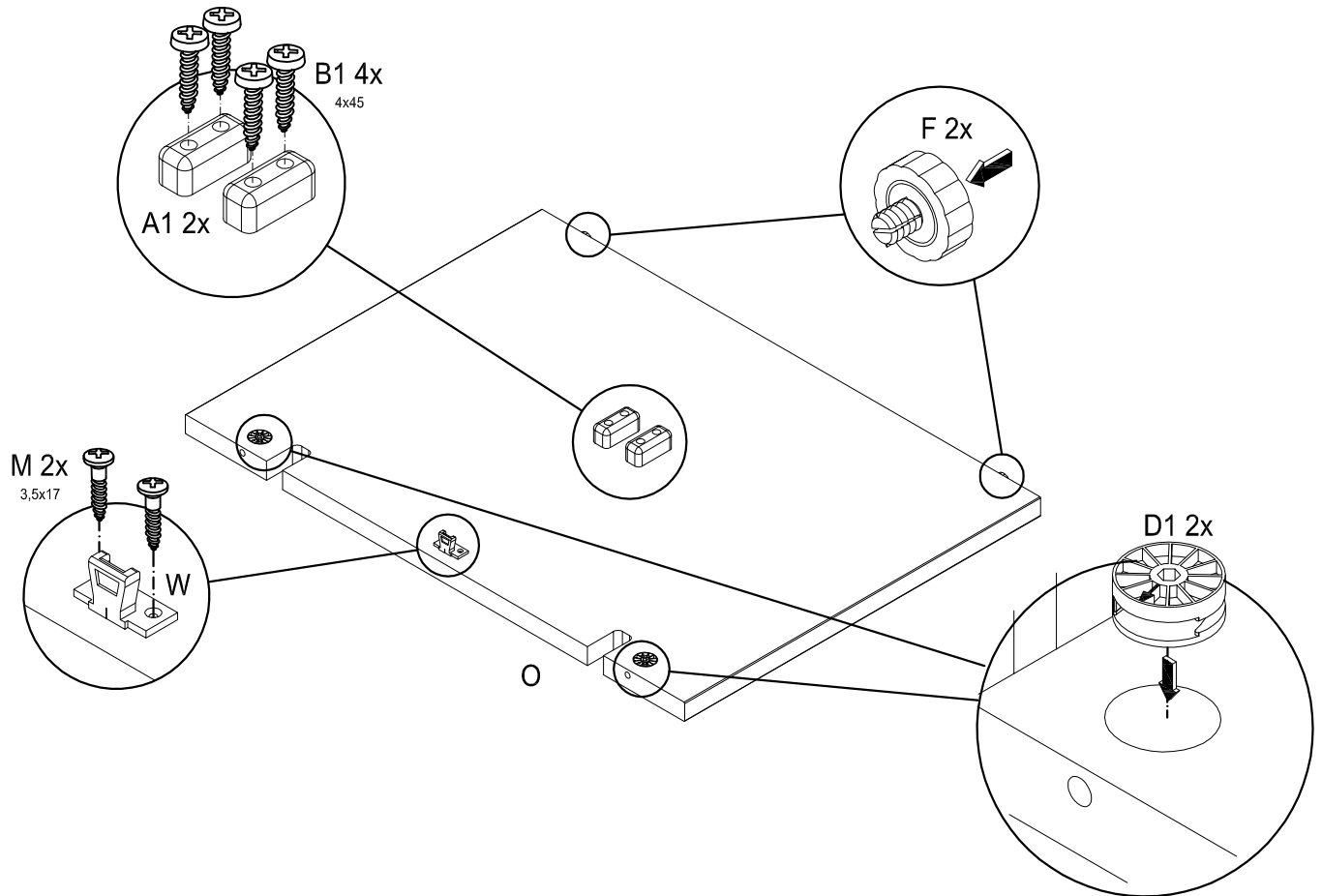

Markierungspfeil muß zur Bohrung in der Bauteilkante zeigen!

7

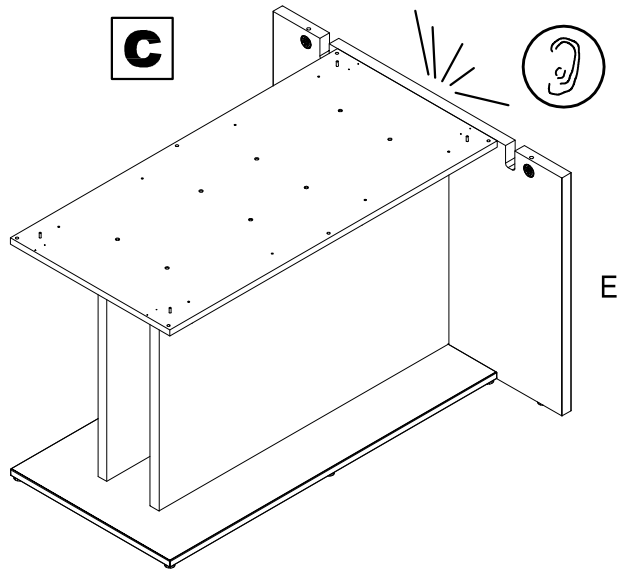
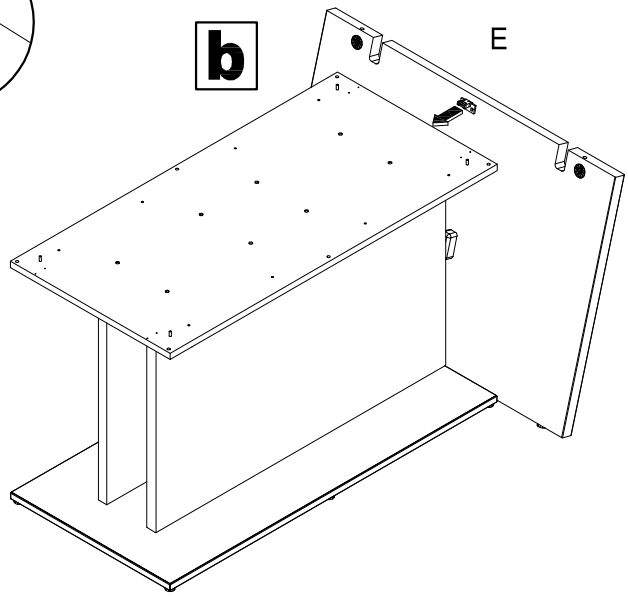
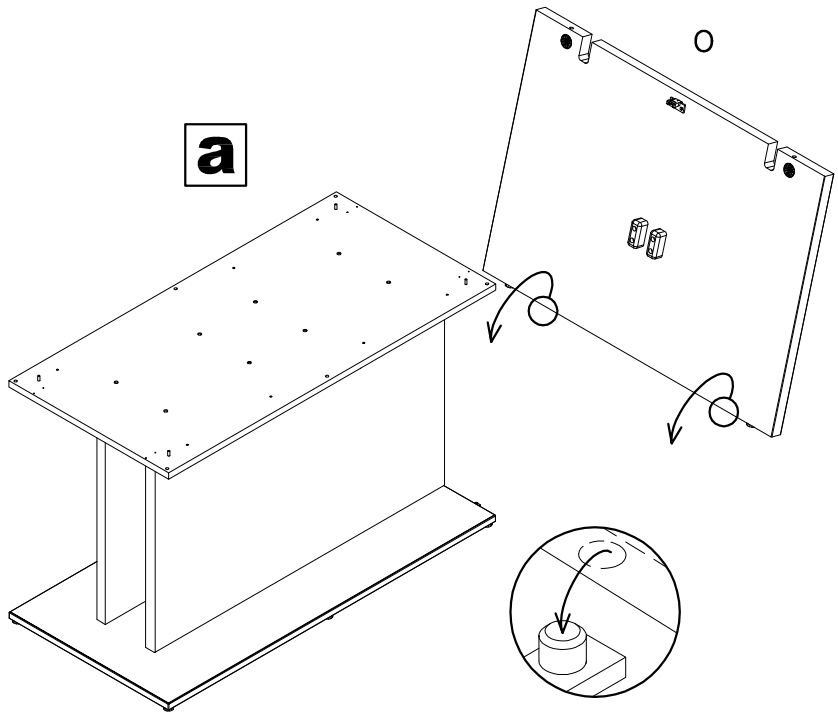

8

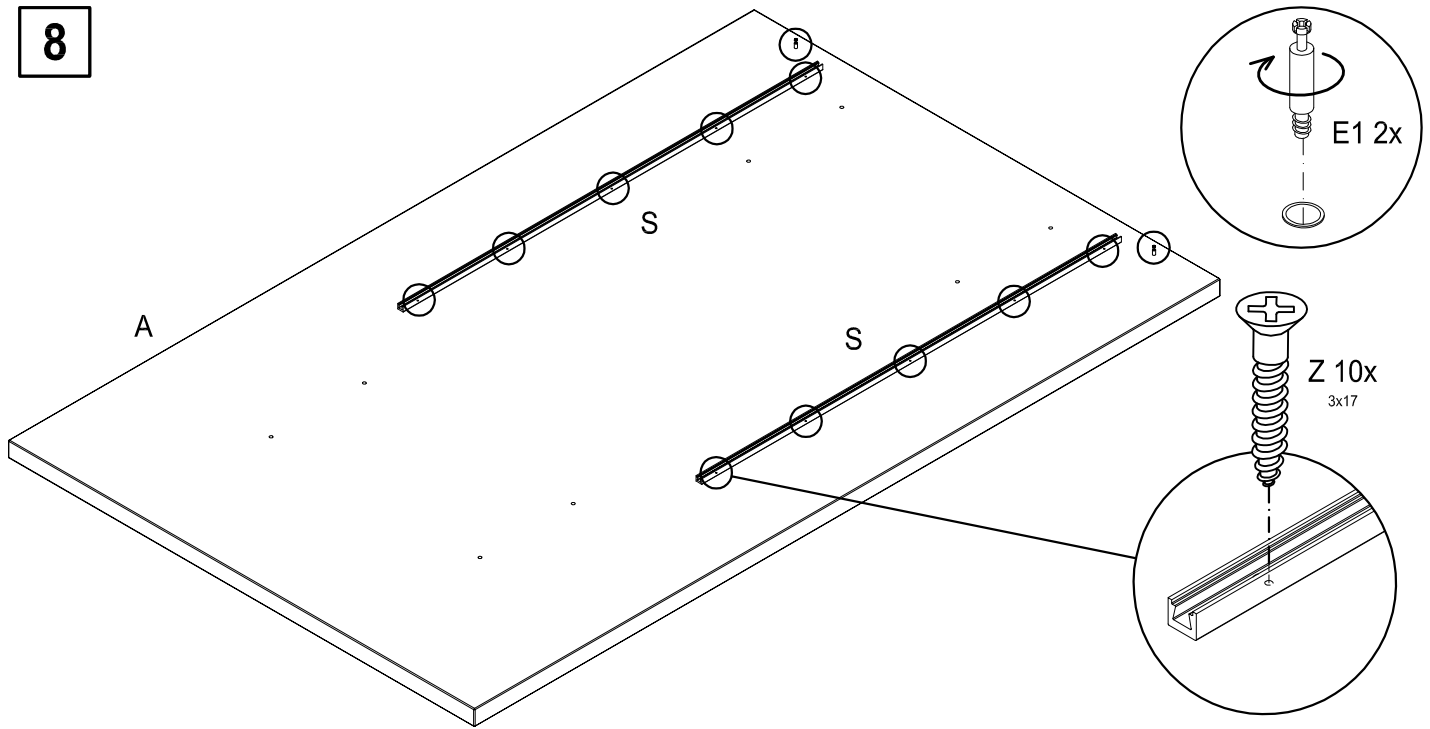

9

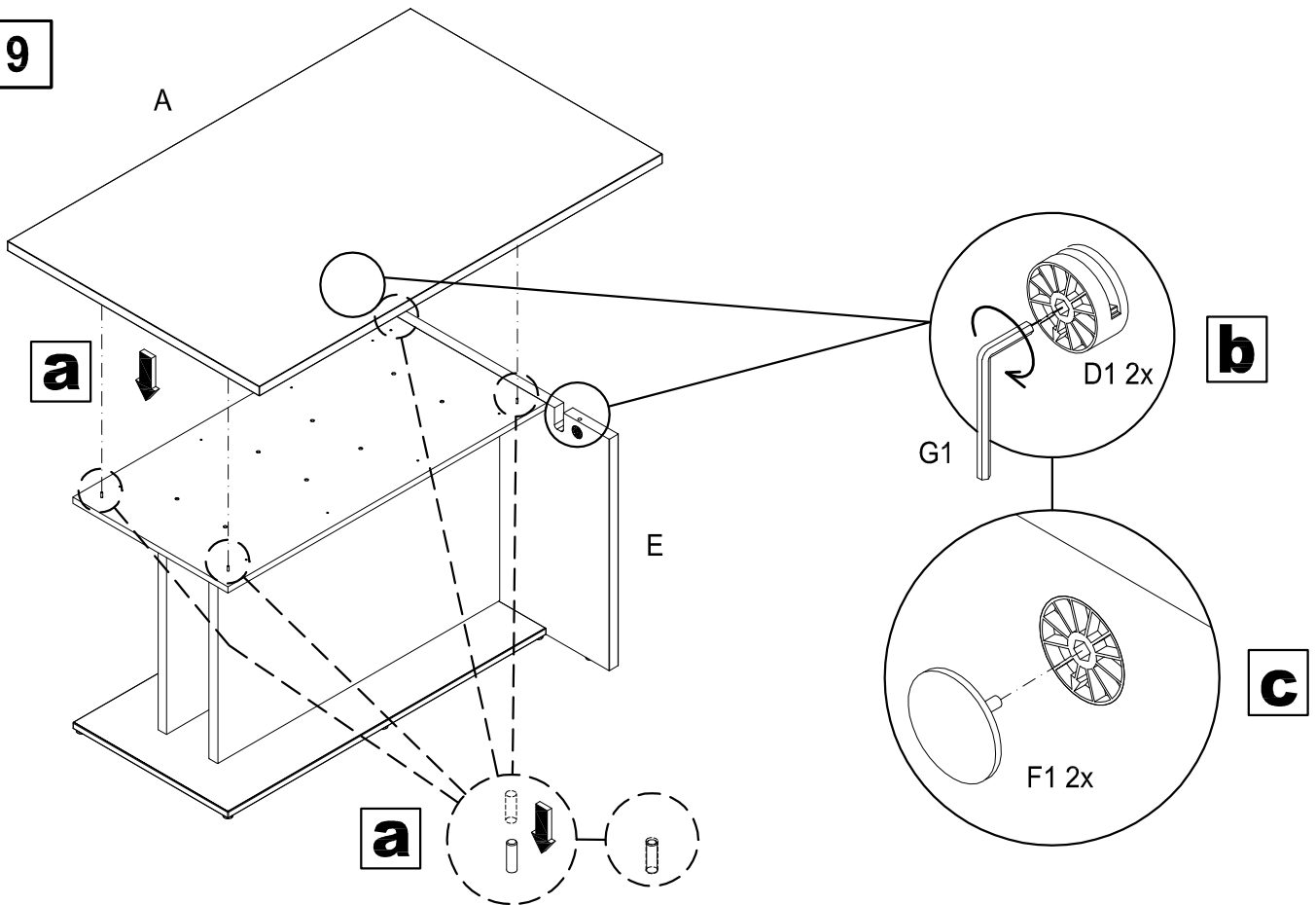

10

a

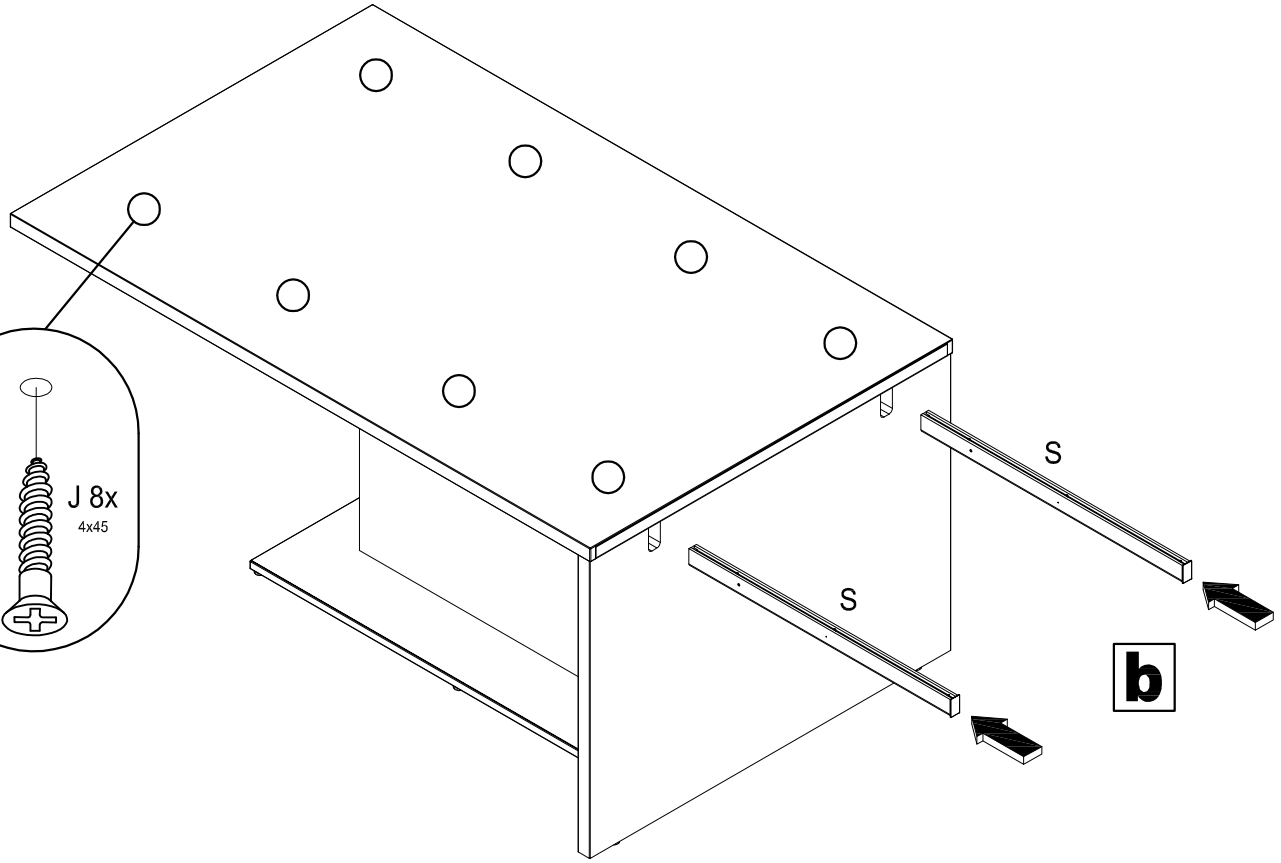
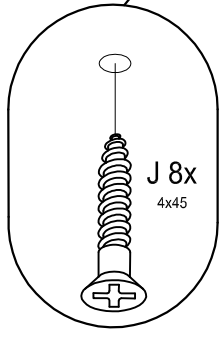

11

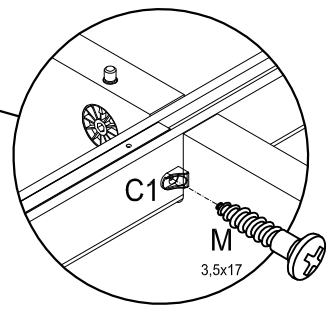
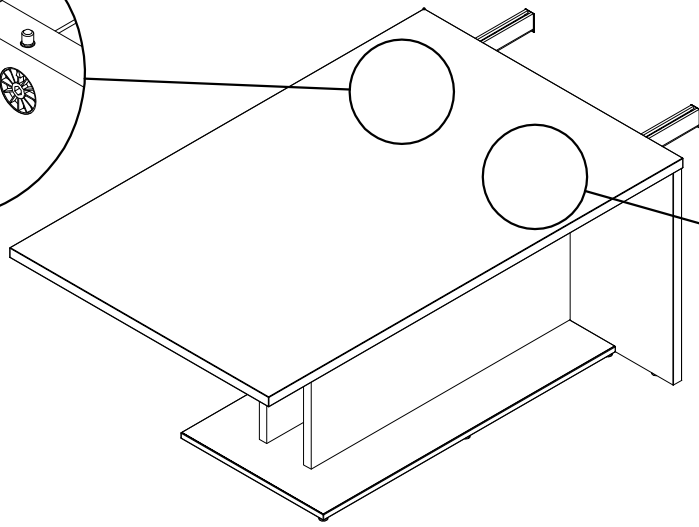
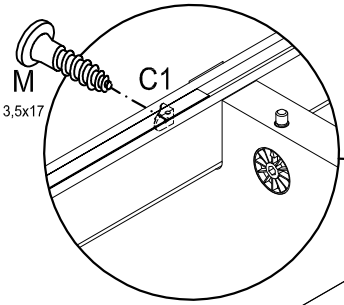

12

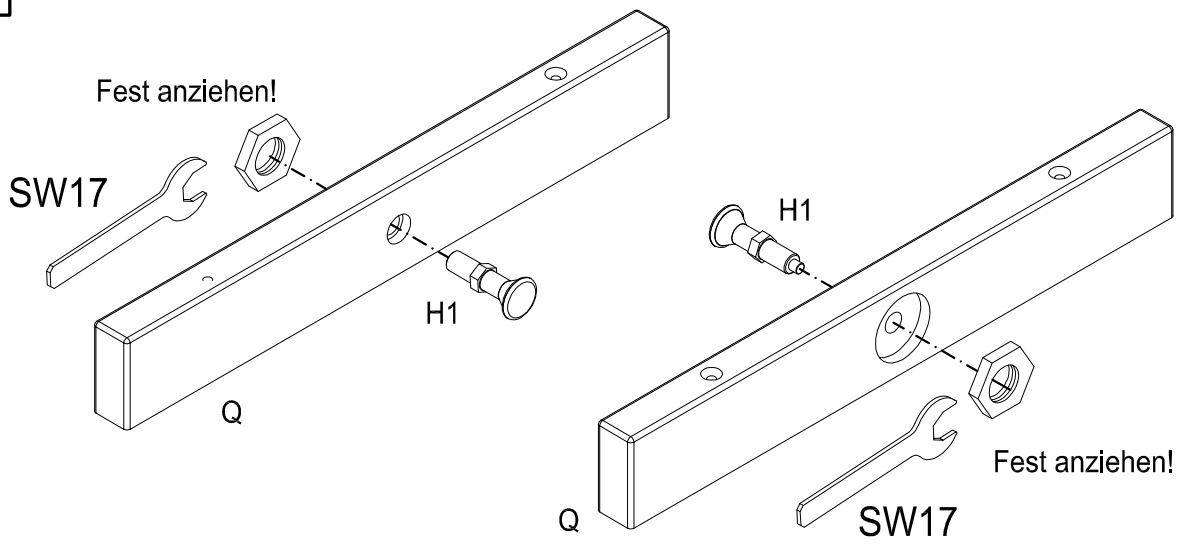

13

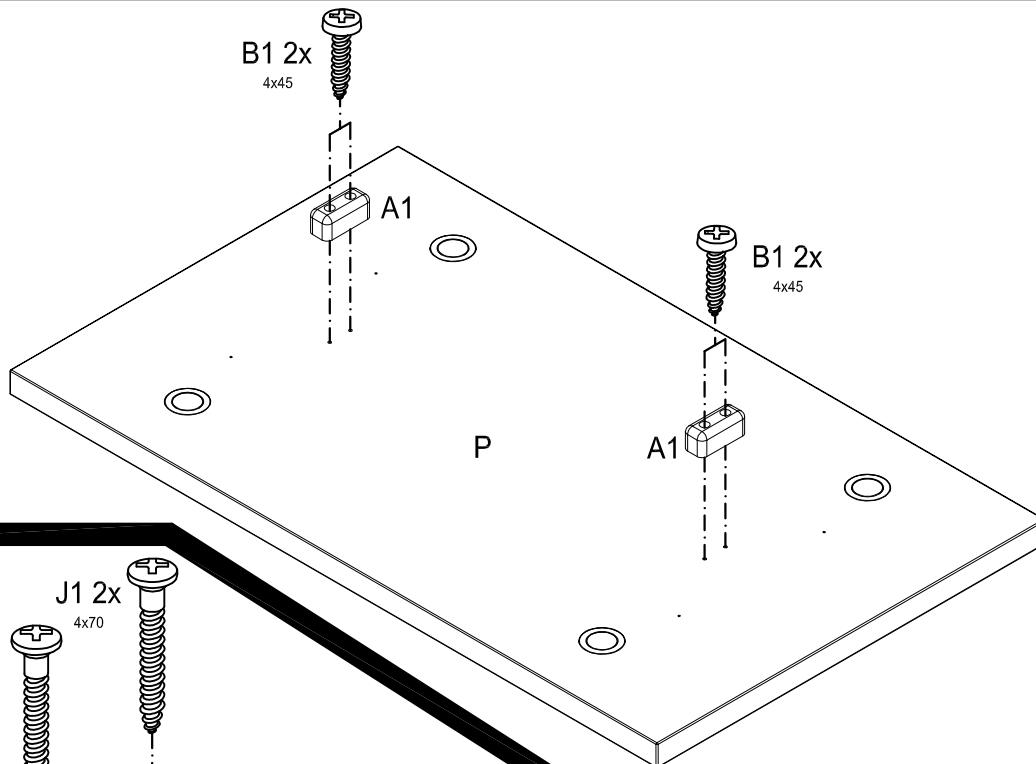

14

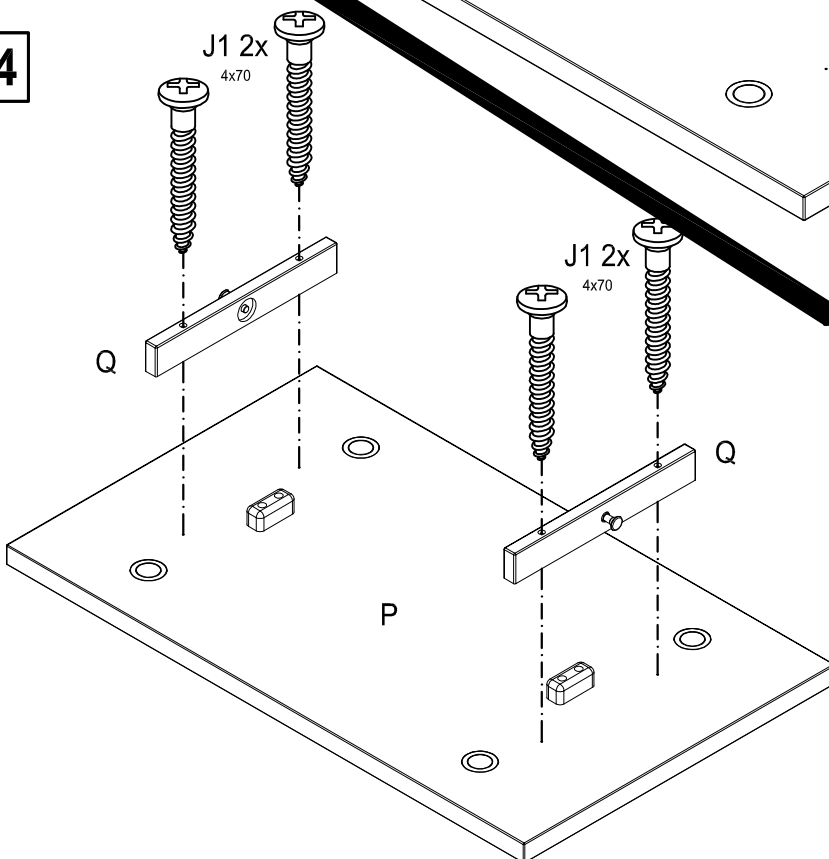

15

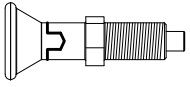
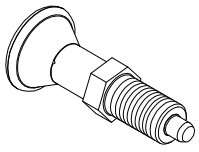

Bolzen ausgefahren

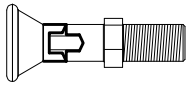
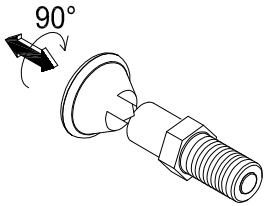

Bolzen eingefahren

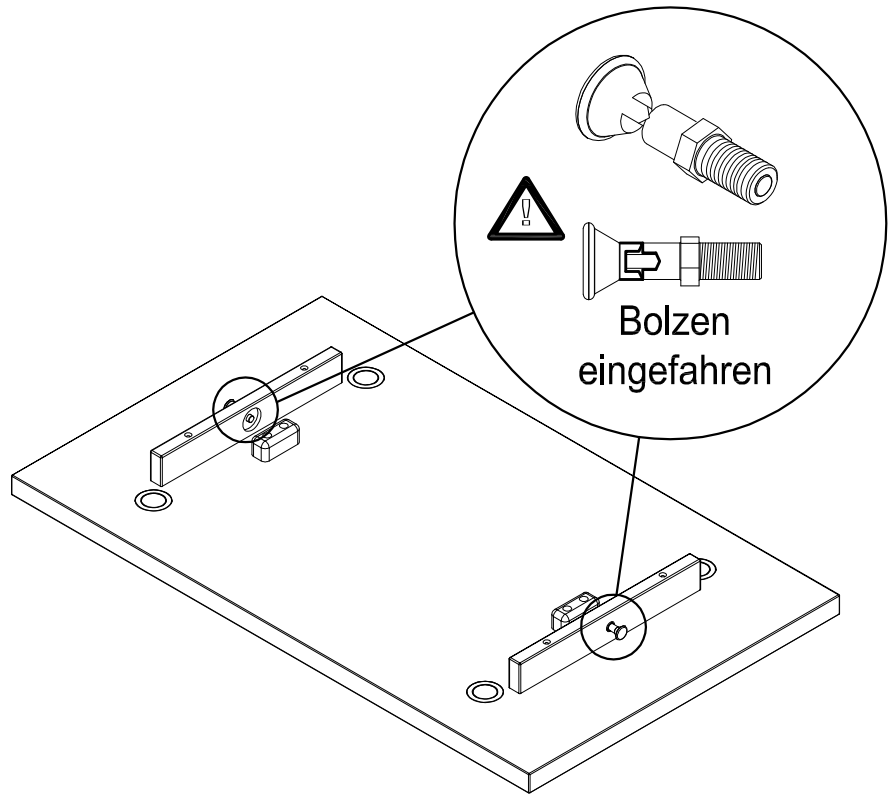

16

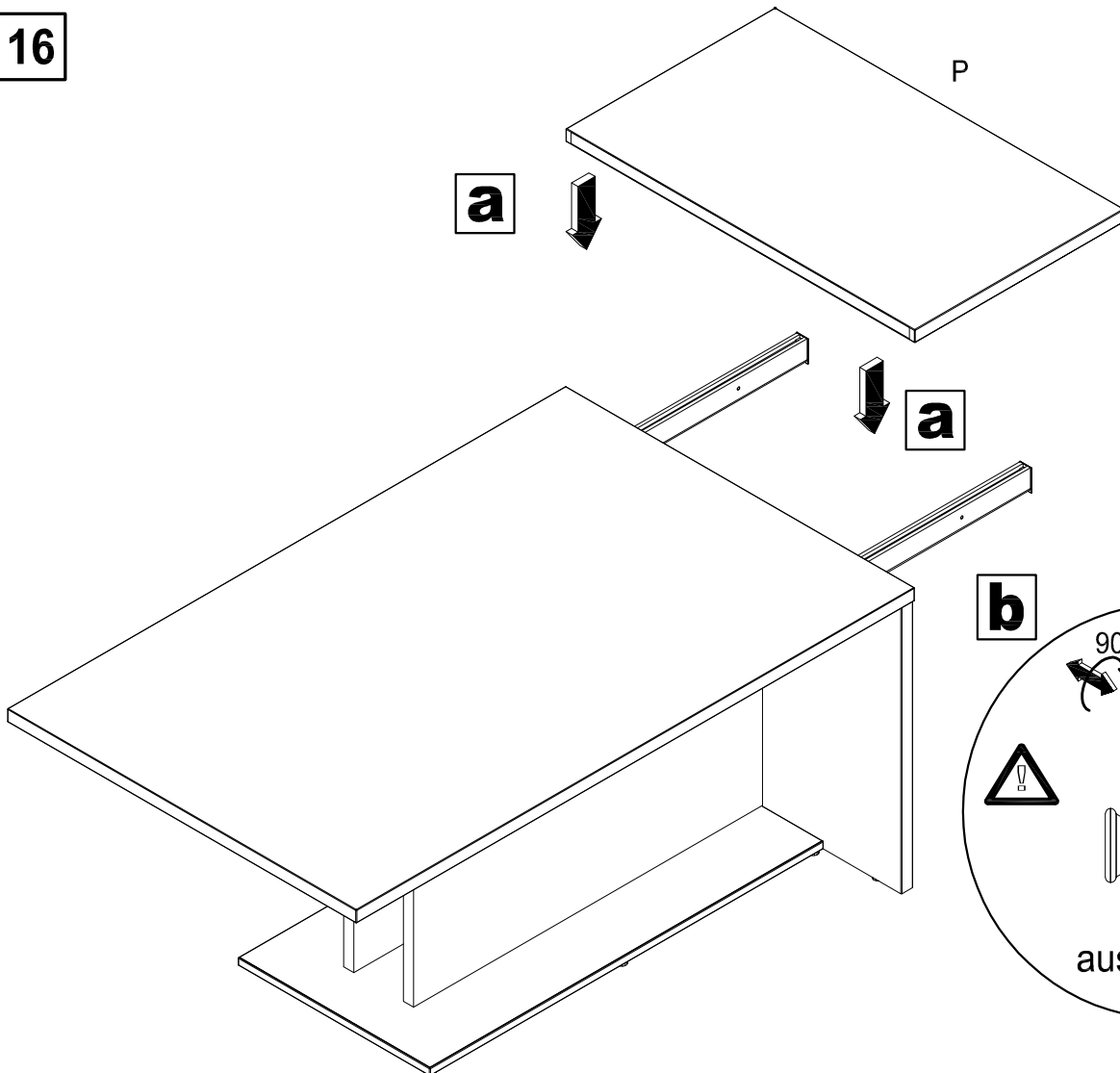

17

Höhenverstellung
Hight adjustment
Règlage en hauteur
Hogteverstelling

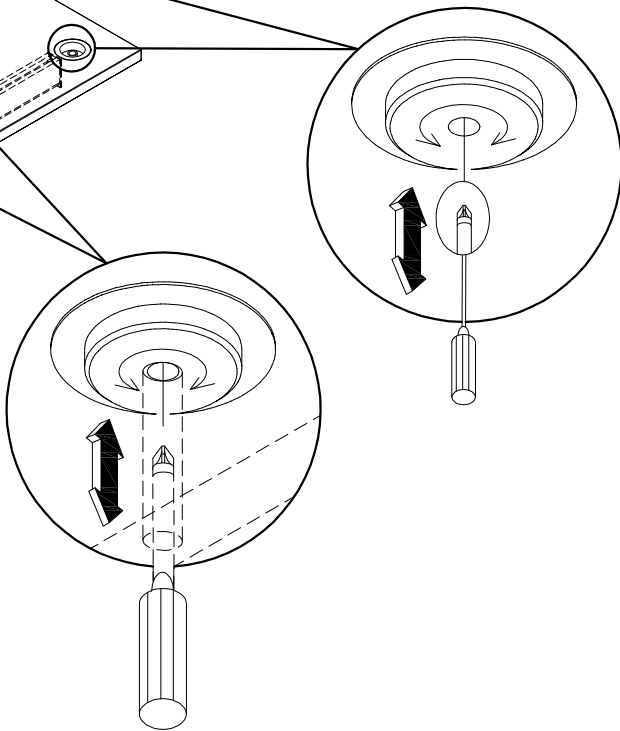
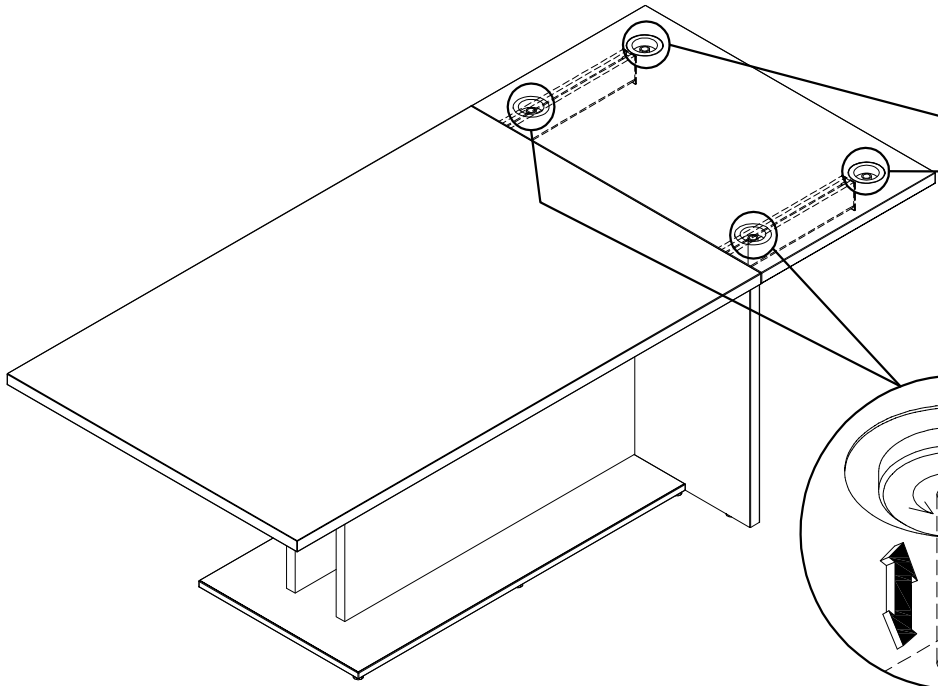
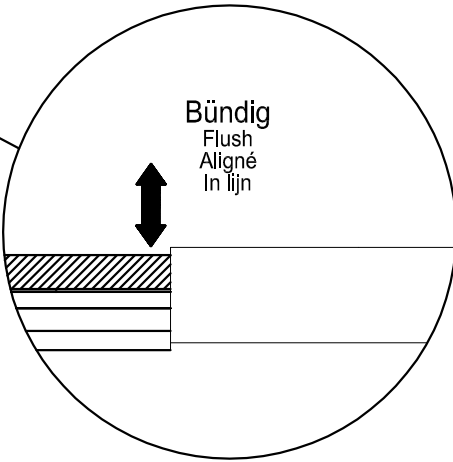
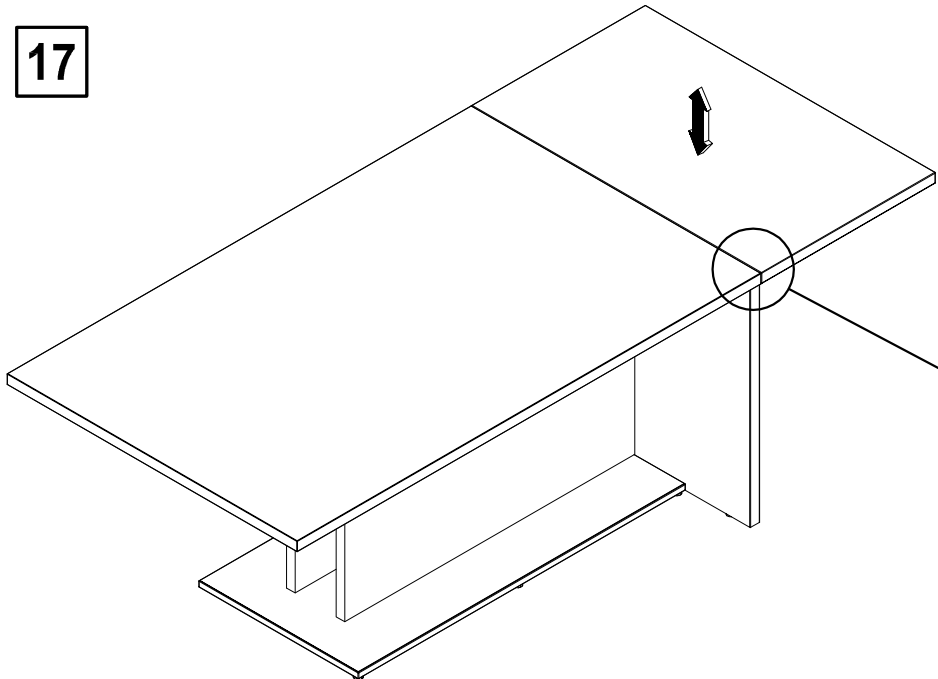

18

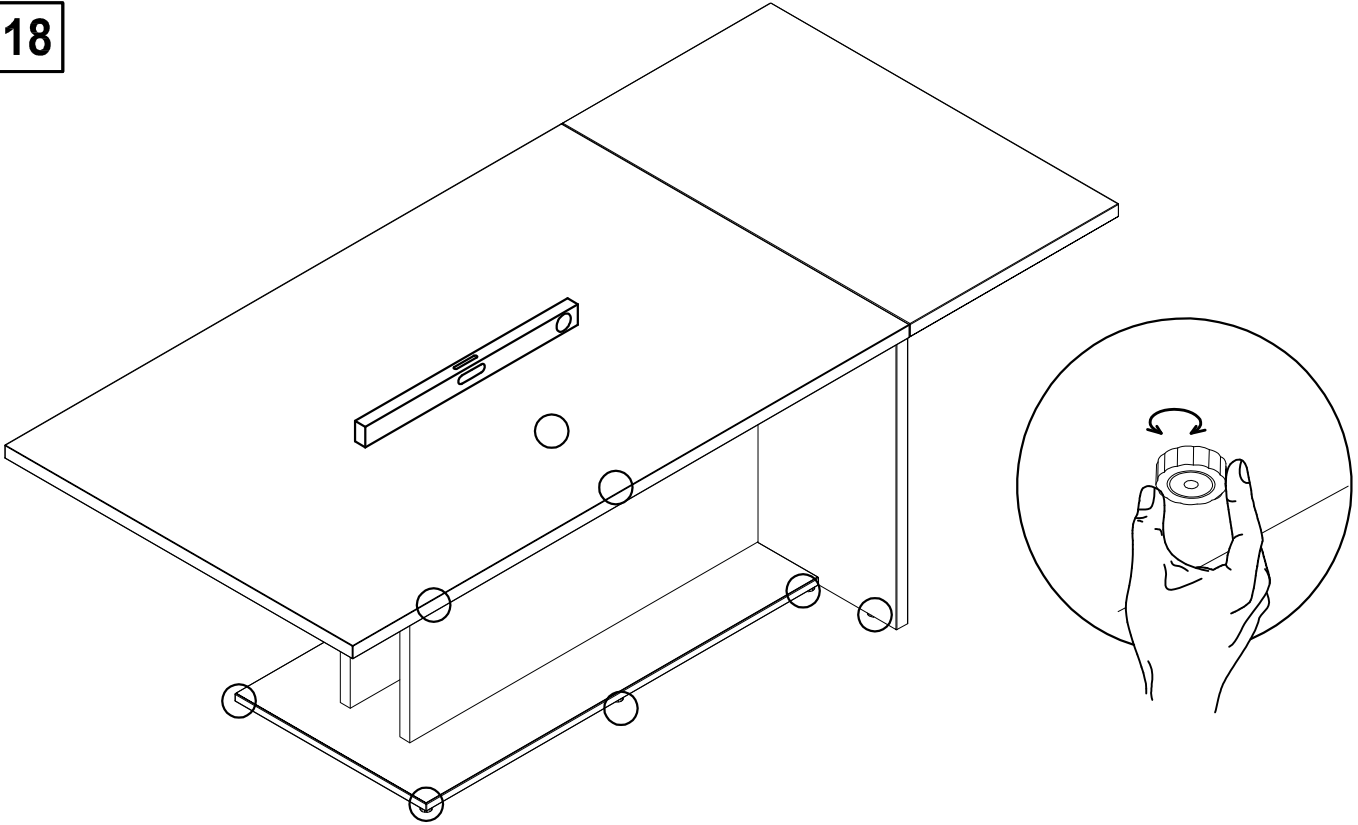

19

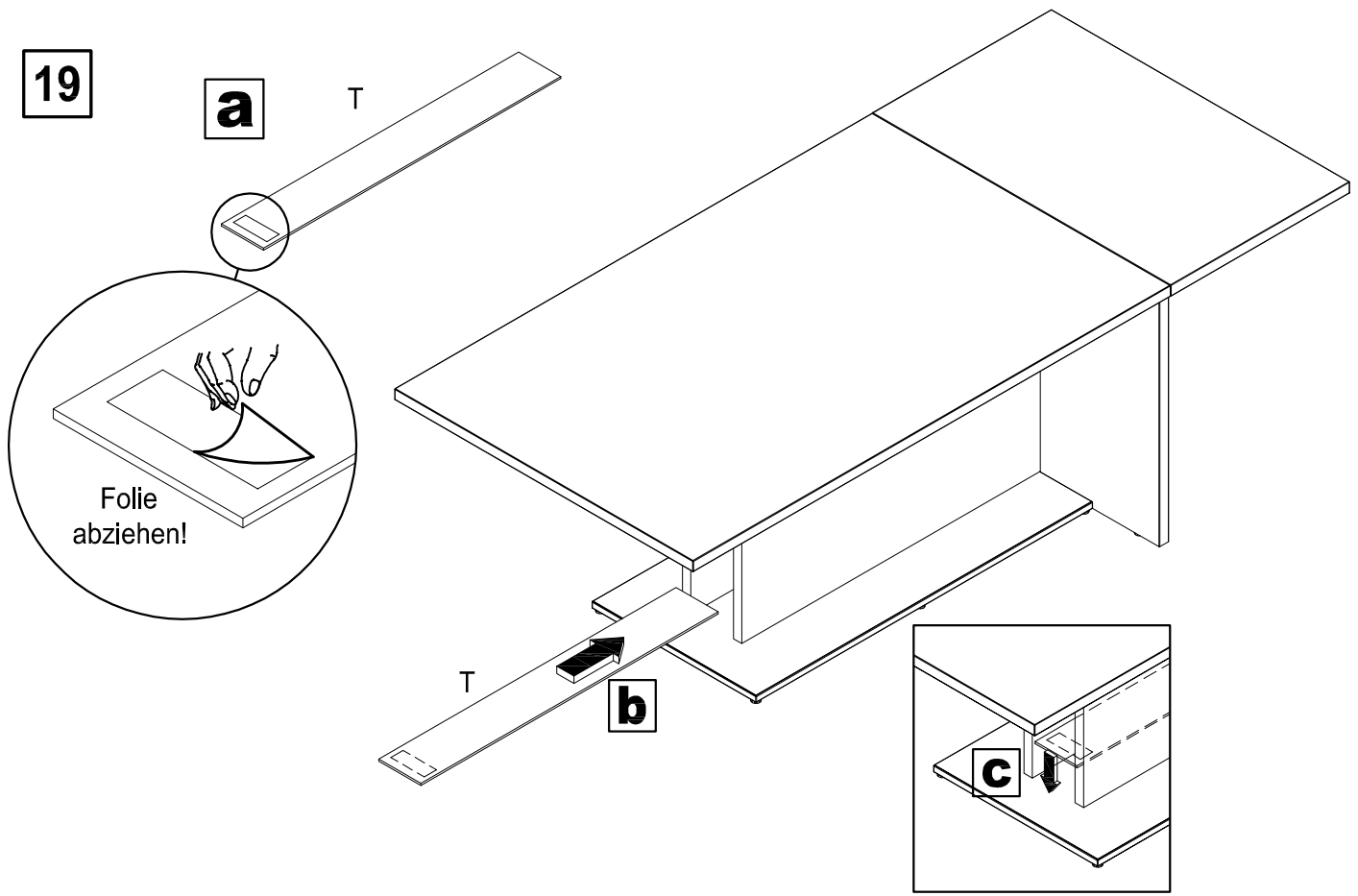

20 Demontage Anlegeplatte

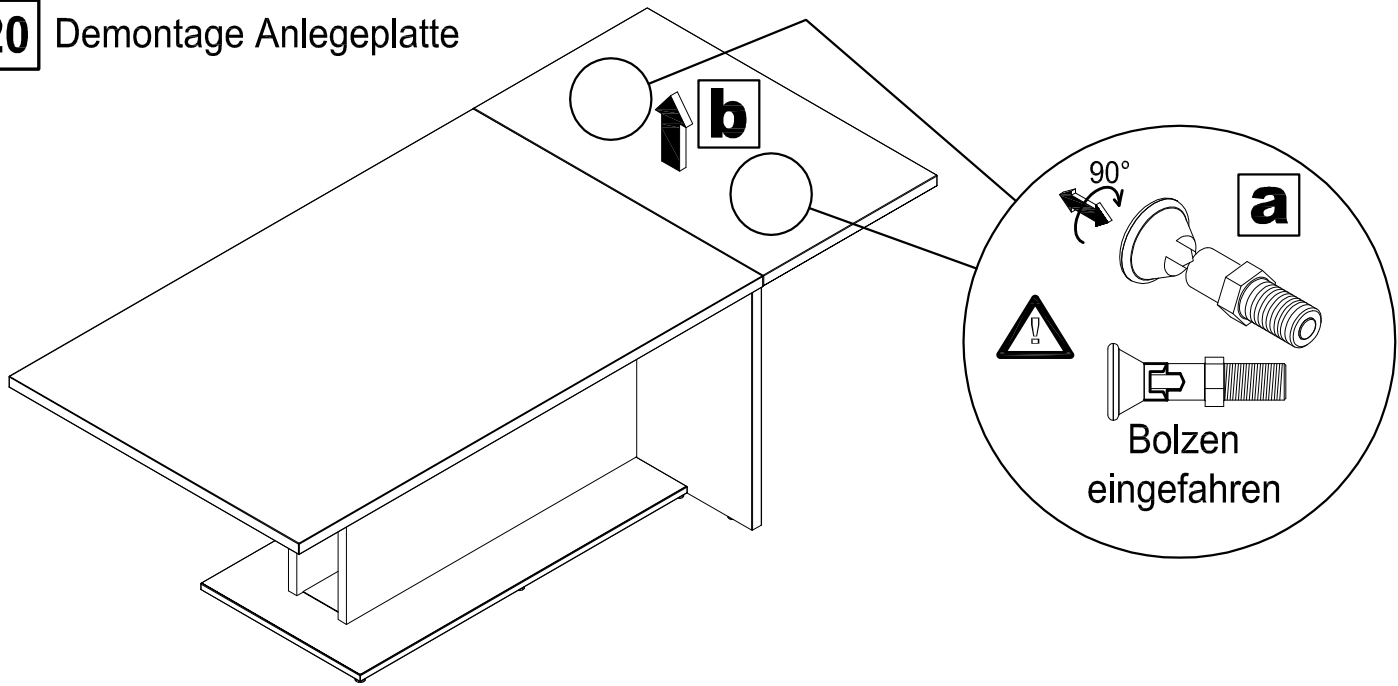

21

