

# now time

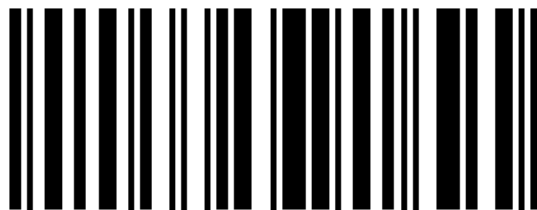

1840421

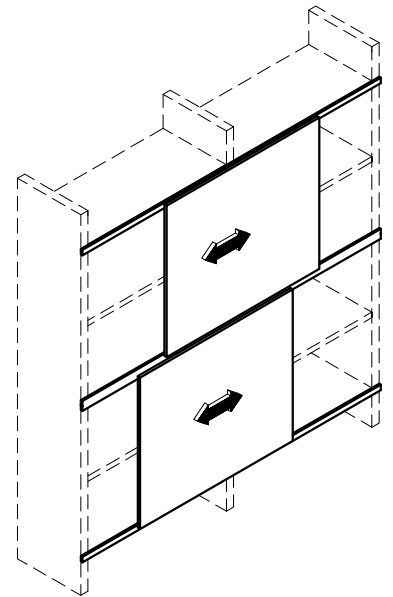
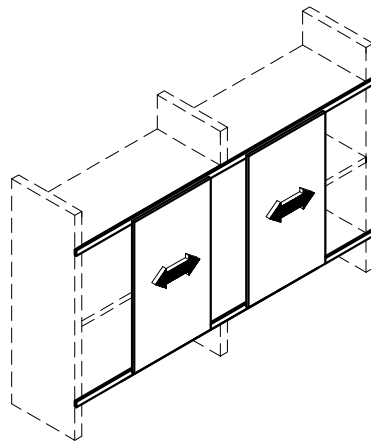
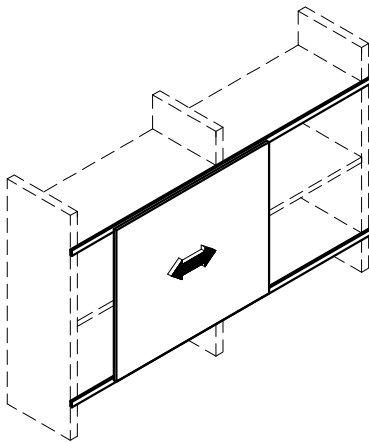
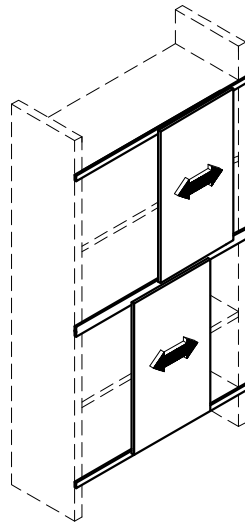
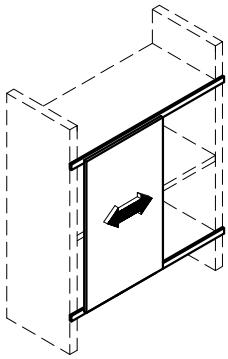
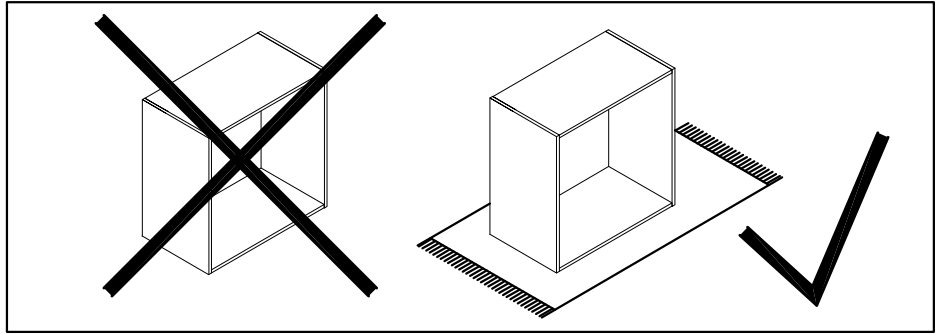
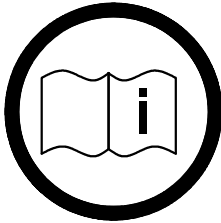
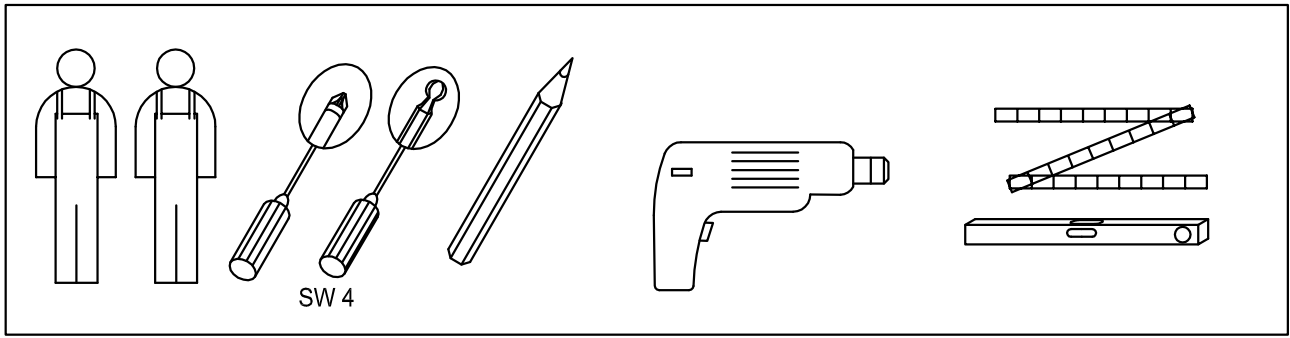

**4-10**

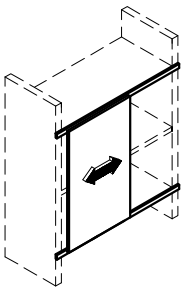

Set 70er	Mat. NO90_L438822	
2x		1390 mm
2x		1390 mm

**11-17**

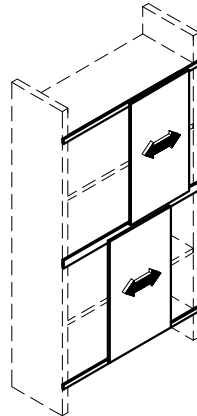





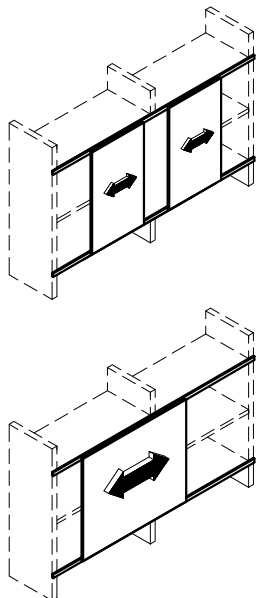



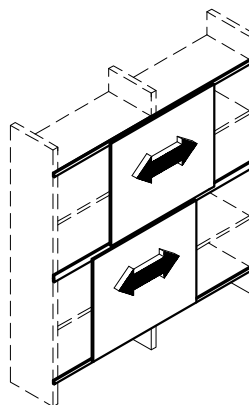

Set 70er	Mat. 1838924	
3x		1390 mm
3x		1390 mm



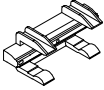
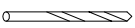
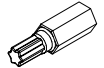

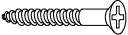

Set 140er	Mat. NO90_L438622	
2x		2789 mm
2x		2789 mm
1x		1364 mm











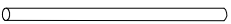

Set 140er	Mat. 1562682	
3x		2789 mm
3x		2789 mm
2x		1364 mm



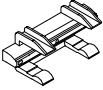
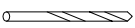
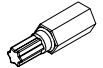

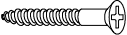



BB 2153		Mat. 1484877	
2x		R	
2x		L	
4x			
2x			
2x			
1x		Ø3 mm	
1x		T15	
20x		4x35	
5x		4,5x50	
4x		3,5x40	
1x		SW 1,5 SW 2	
1x			
2x			

BB 2393		Mat. 1561346	
1x		R	
1x		L	
2x			
2x			
10x		4x35	
5x		4,5x50	
4x		3,5x40	

BB 2908		Mat. 1838918	
1x			

BB 2153		Mat. 1484877	
2x		R	
2x		L	
4x			
2x			
2x			
1x		Ø3 mm	
1x		T15	
20x		4x35	
5x		4,5x50	
4x		3,5x40	
1x		SW 1,5 SW 2	
1x			
2x			

BB 2393		Mat. 1561346	
1x		R	
1x		L	
2x			
2x			
10x		4x35	
5x		4,5x50	
4x		3,5x40	

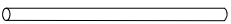
BB 2908		Mat. 1838918	
1x			



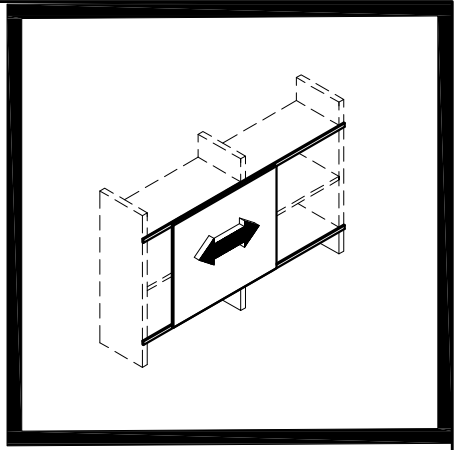
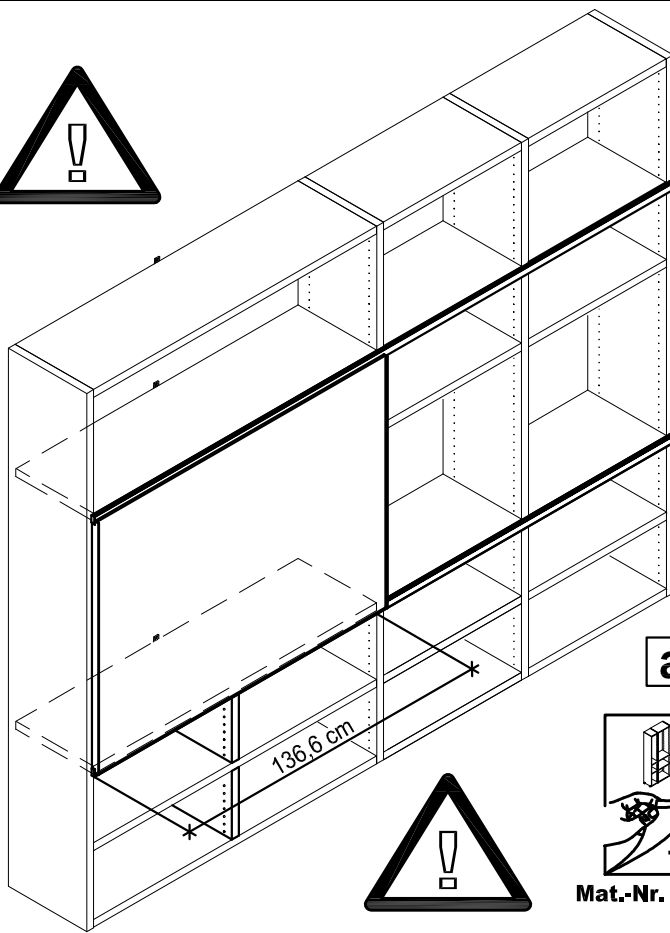

a

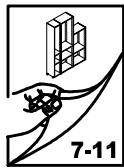

Mat.-Nr. 1840420



1

Set 70er  
Set 140er

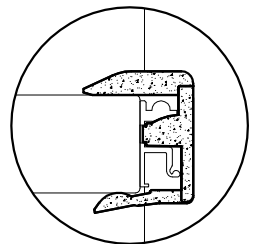
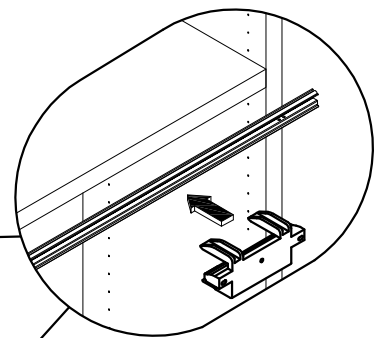
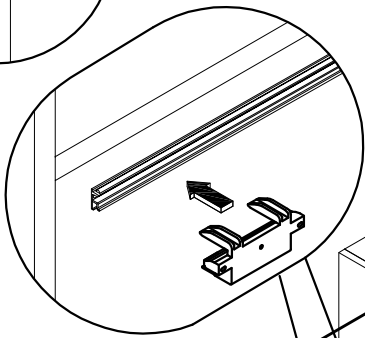
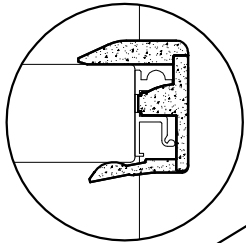
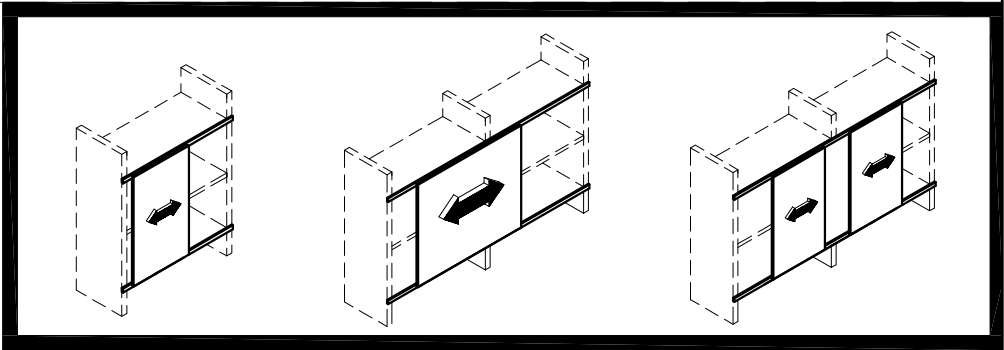

6R = 1088mm  
6R = 1056mm

2

BB 2153

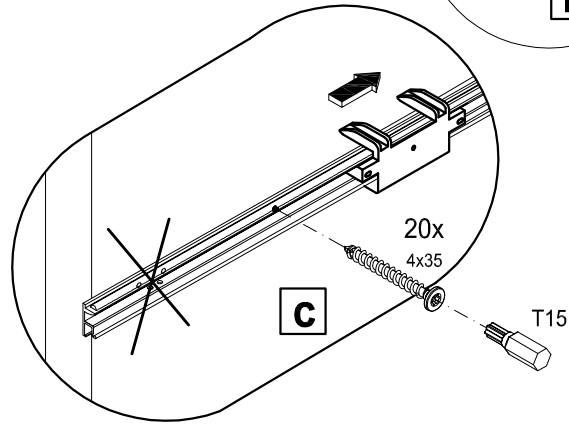
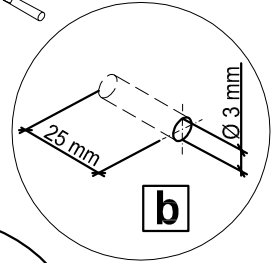
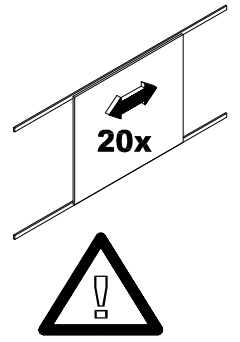
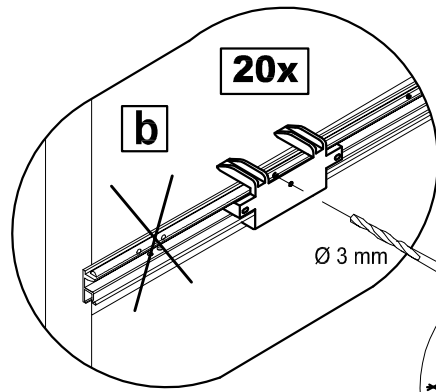
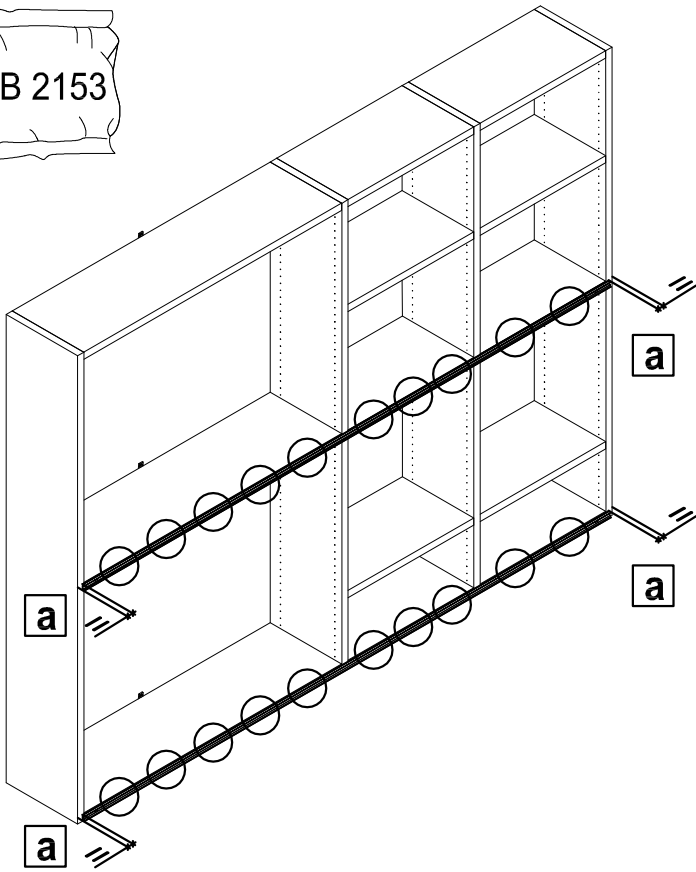

2

BB 2153

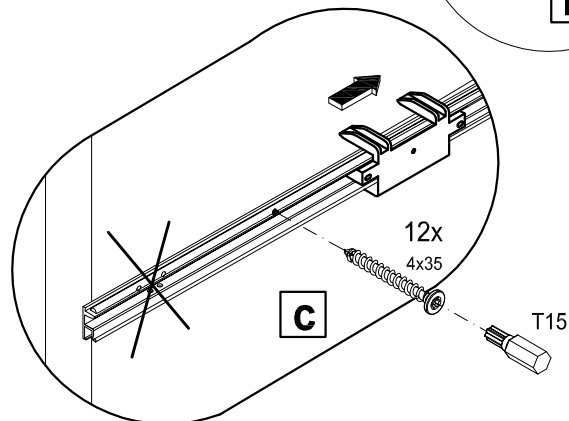
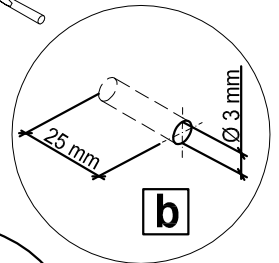
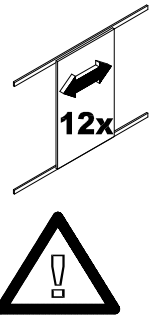
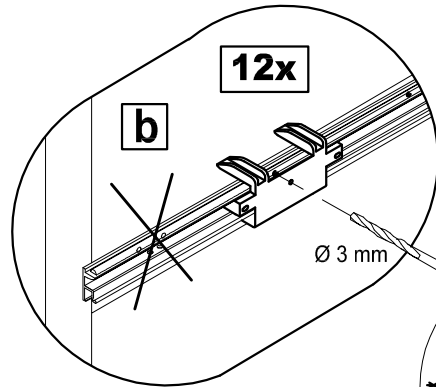
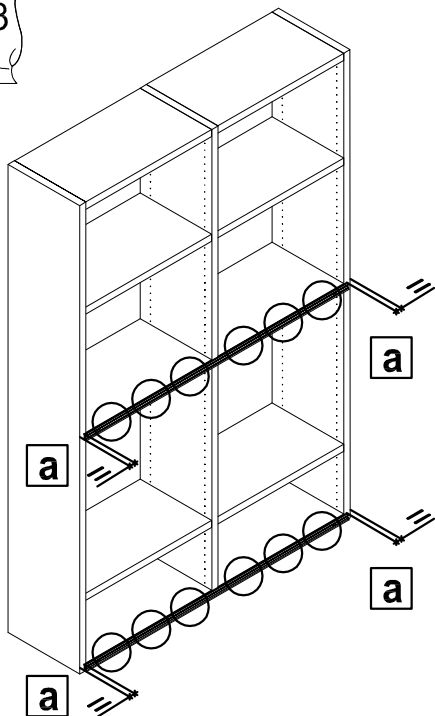

3

BB 2153

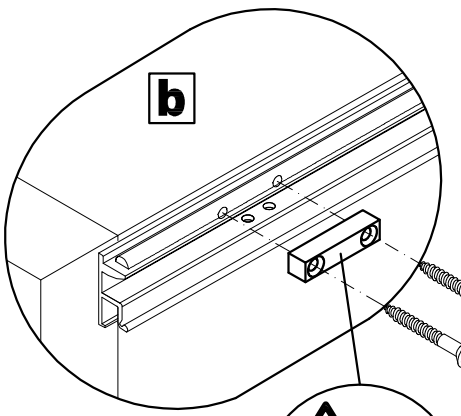
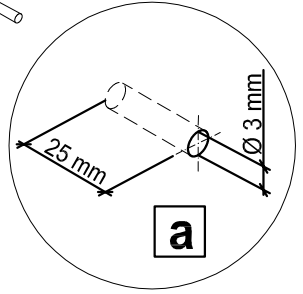
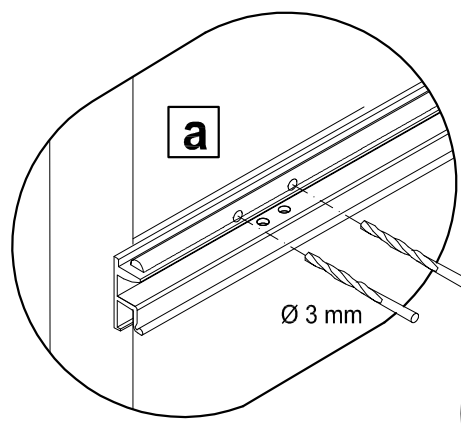
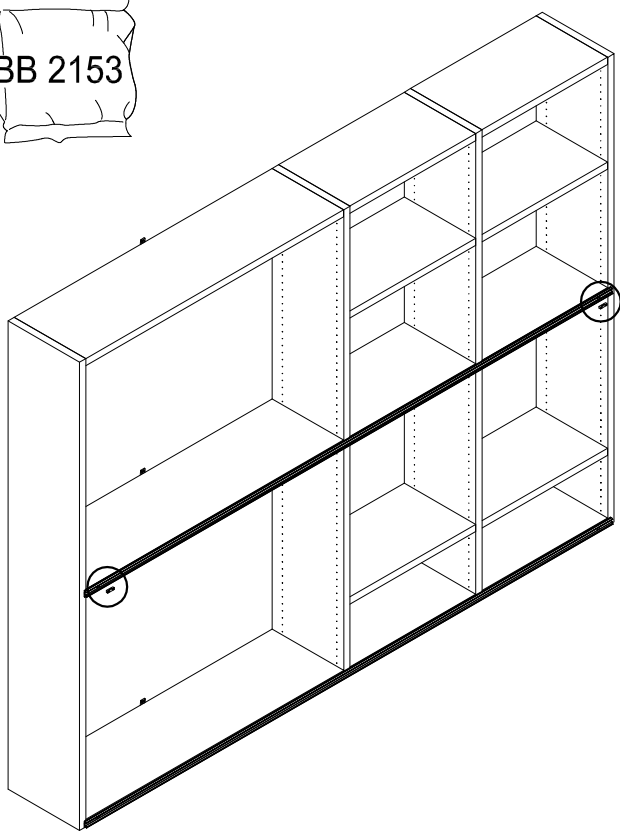

2x  
3,5x40

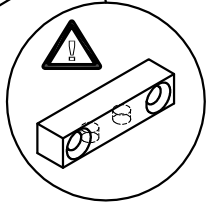

4

Set 70er  
Set 140er

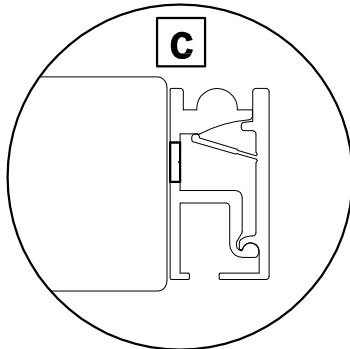
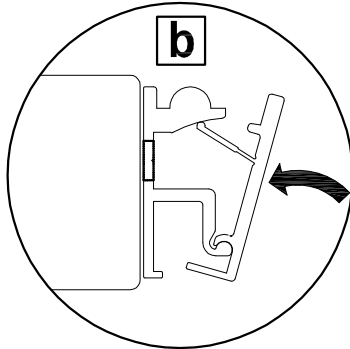
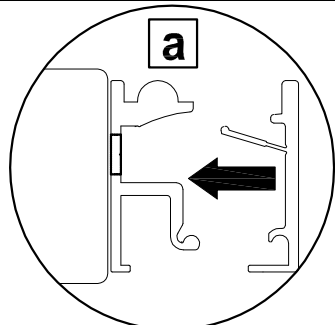
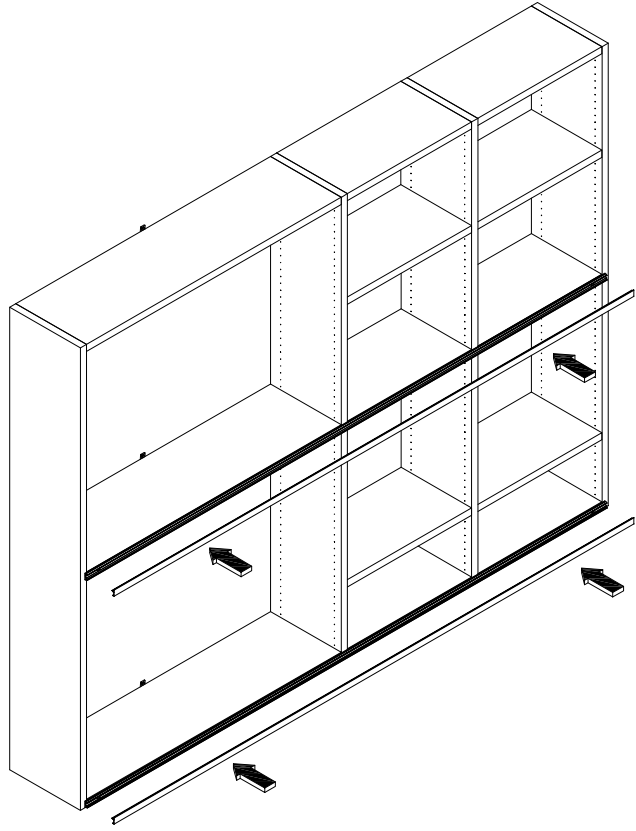

5

BB 2153

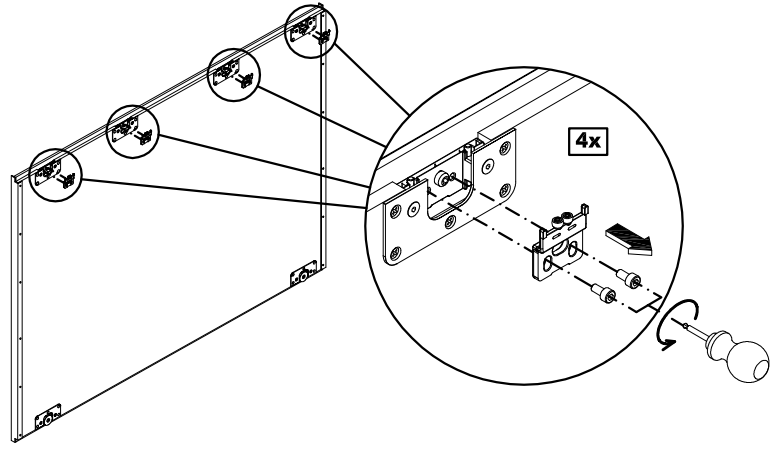
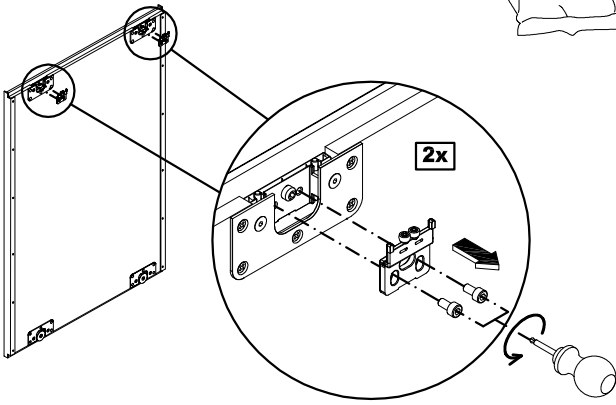

6

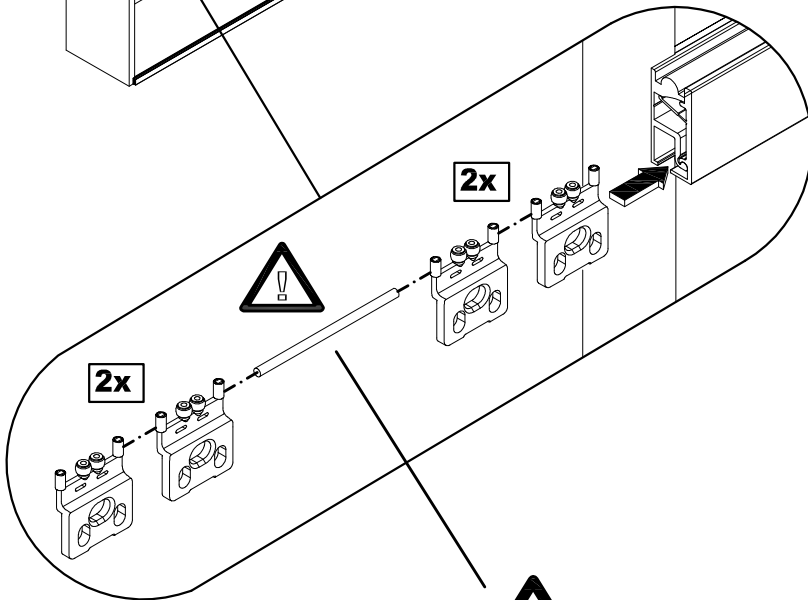
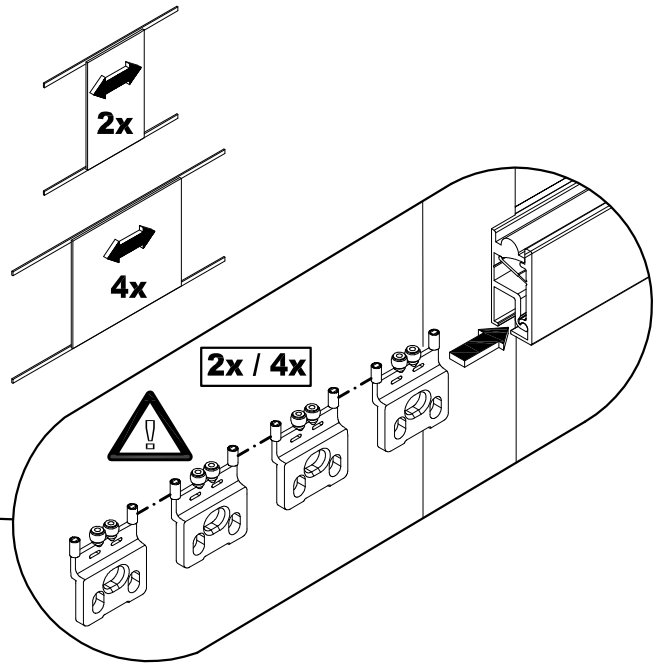
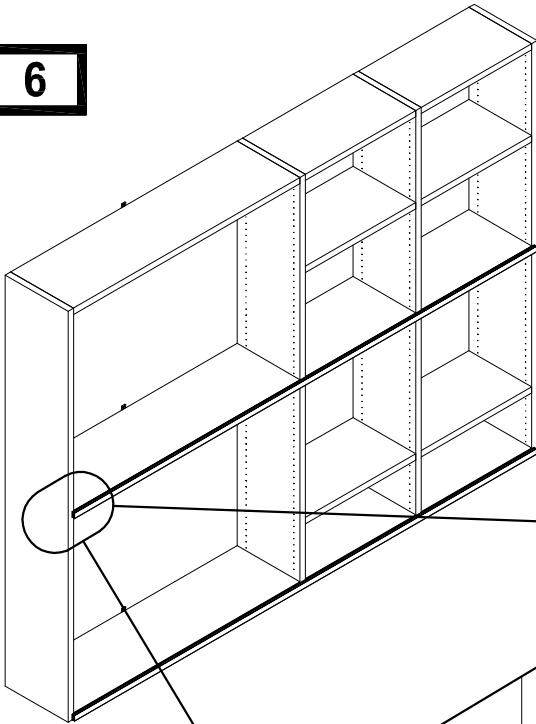

BB 2908

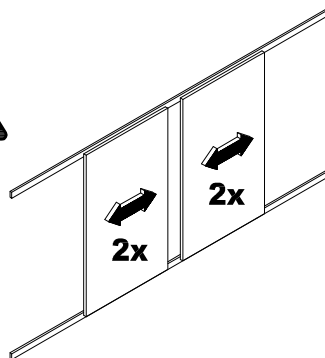

7

BB 2153

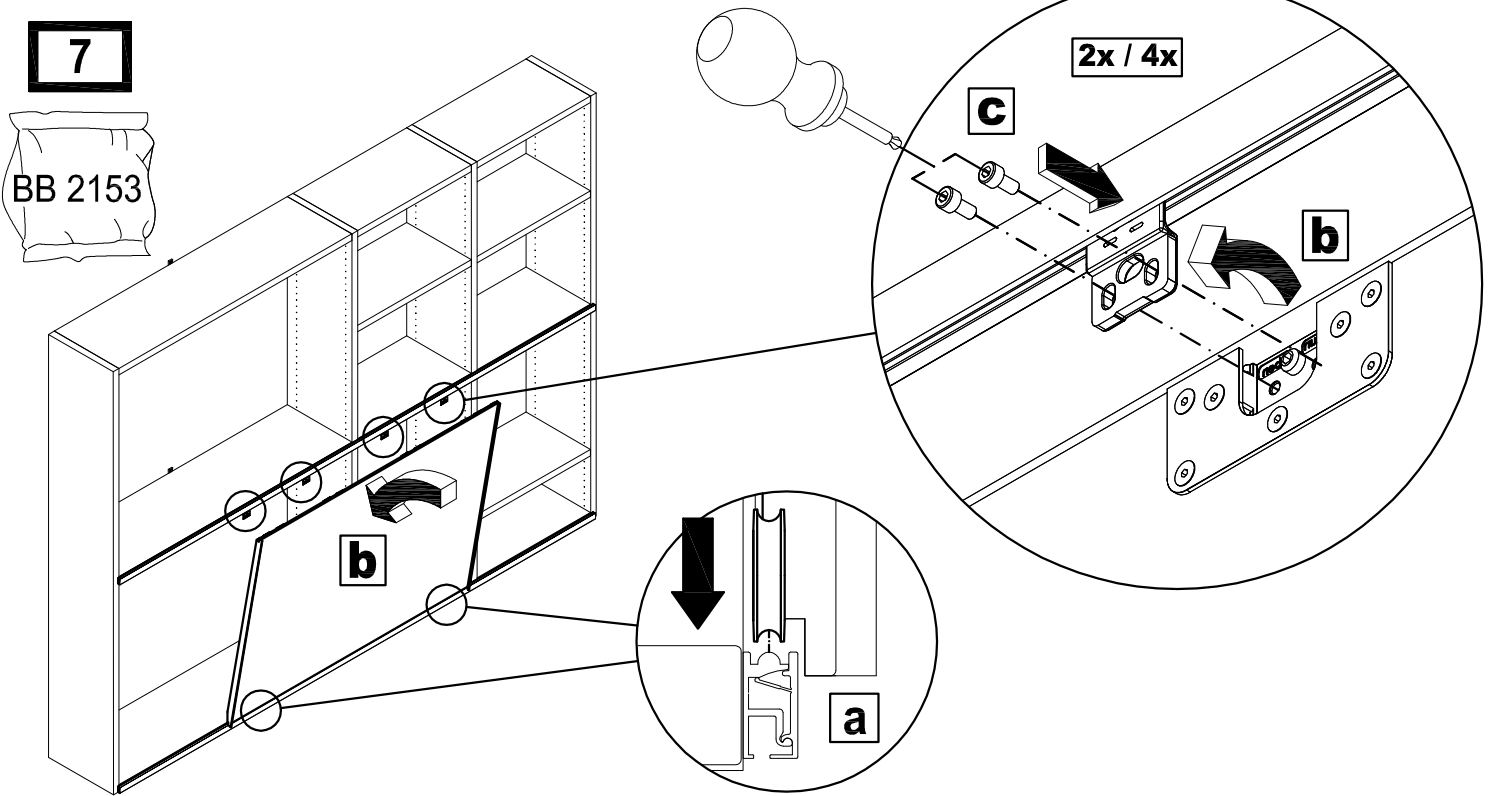

8

BB 2153

a

b

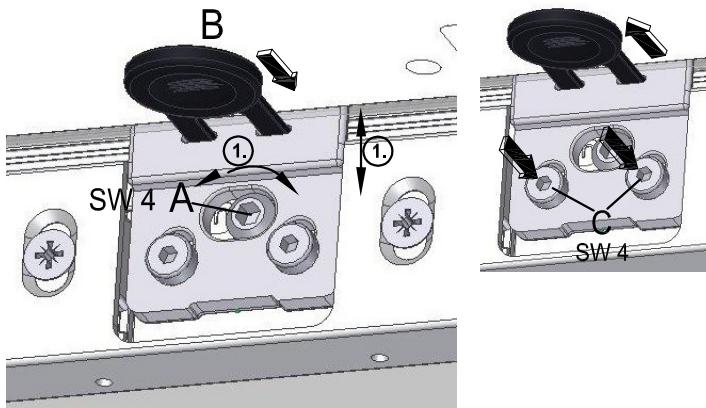

**Die Höheneinstellung über den gesamten Laufweg prüfen, eventuell die Ausrichtung des Möbels korrigieren.**

Check the height setting over the entire length of the rail, correct the unit settings if necessary.

*Le réglage en hauteur est à contrôler sur l'ensemble du trajet. Corriger éventuellement l'aplomb du meuble.*

Instelling van de hoogte over de gehele loop-traject controleren. Eventueel de waterpasstelling van het meubel corrigeren.

**Höheneinstellung des Führungsbeschlages über Excenter (A). Wenn die Einstellhilfe (B) an der Unterseite der Laufschiene anliegt, ist die optimale Einstellung erreicht! Schrauben (C) fest anziehen**

Height adjustment via excenter screw (A). The perfect setting is achieved when the adjuster aid (B) rests on the underside of the guiderail! Tighten screws (C) firmly.

*Réglage en hauteur de la ferrure de guidage à l'aide de l'excentrique (A). Le réglage optimal est obtenu lorsque la pièce pour l'aide au montage (B) repose sur la face inférieure du rail!*

*Serrer les vis (C).*

Instelling van de hoogte van het geleidingsbeslag via excenter (A). Als de instelhulp (B) vlak tegen de onderkant van de rail ligt, is de optimale instelling bereikt! Schroeven (C) vastdraaien.

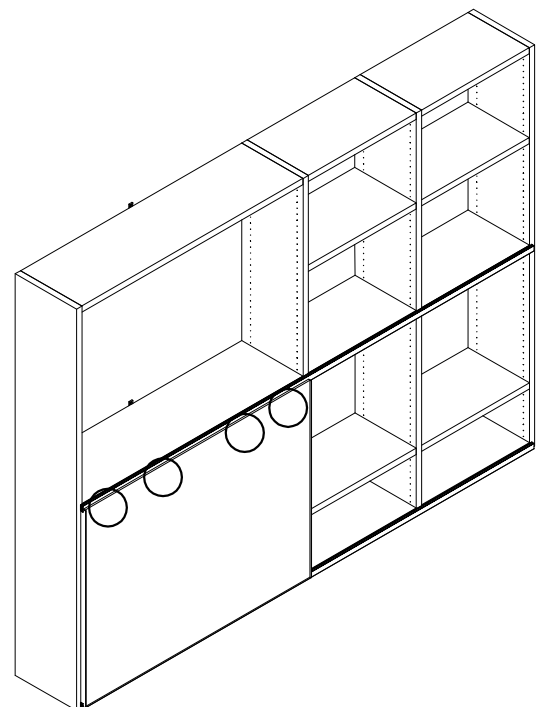



9

BB 2153

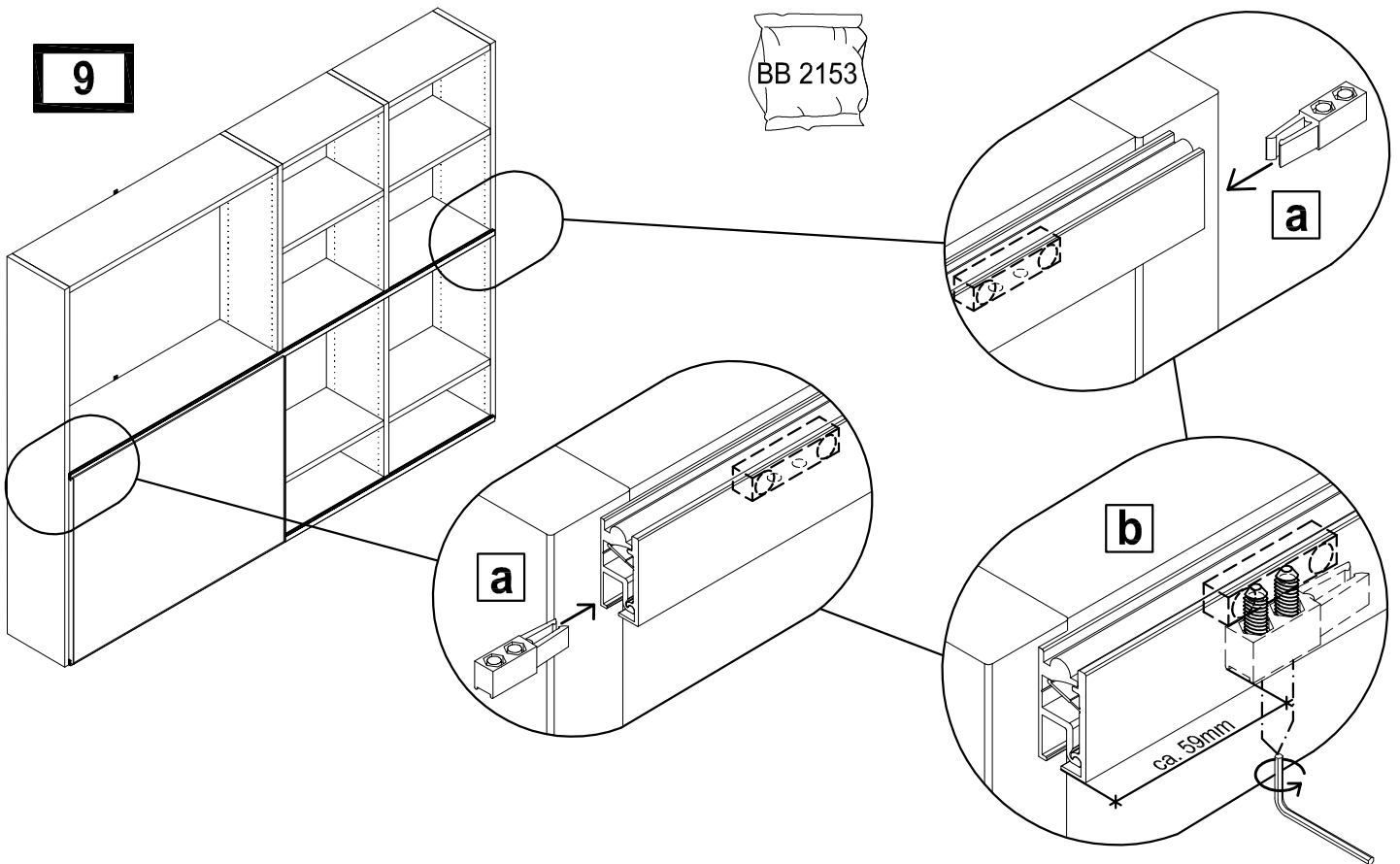

**Gewindeschrauben des Stoppers in Anschlaghalterung mit 5-6 Umdrehungen eindrehen.**

Screw the threaded screws of the stopper into the stop holder by turning them 5-6 times.

*Effectuez 5-6 tours de la vis filetée de l'arrêt dans le support de butée.*  
Draai de schroeven van stopper 5-6 rotaties in aanslaghouder.

10

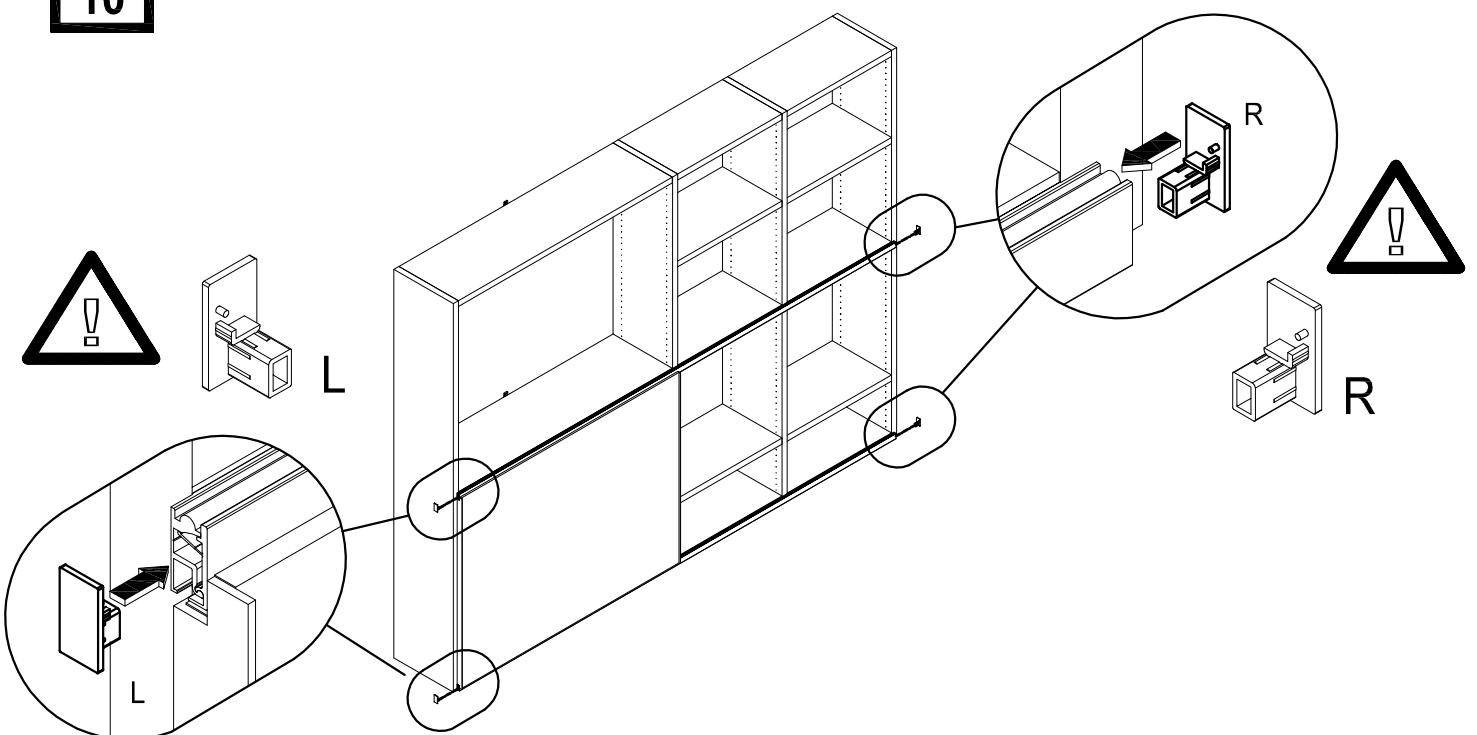

11

BB 2153  
Set 140er

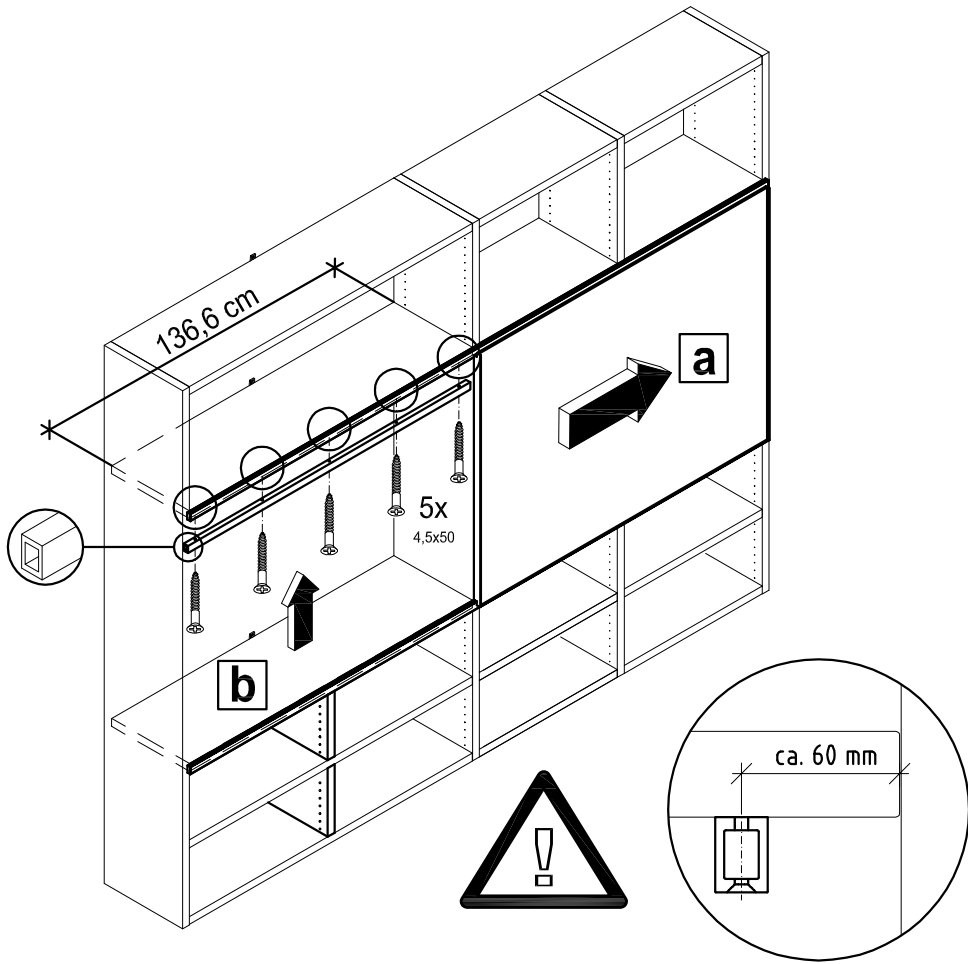

1

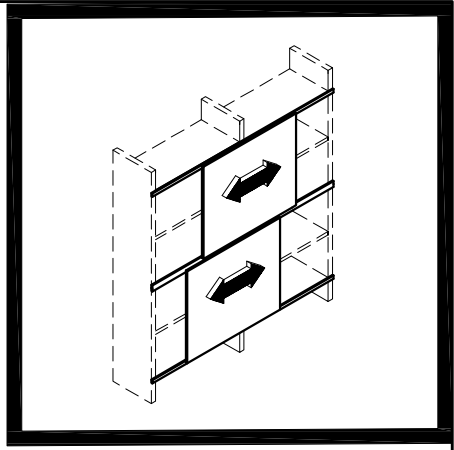
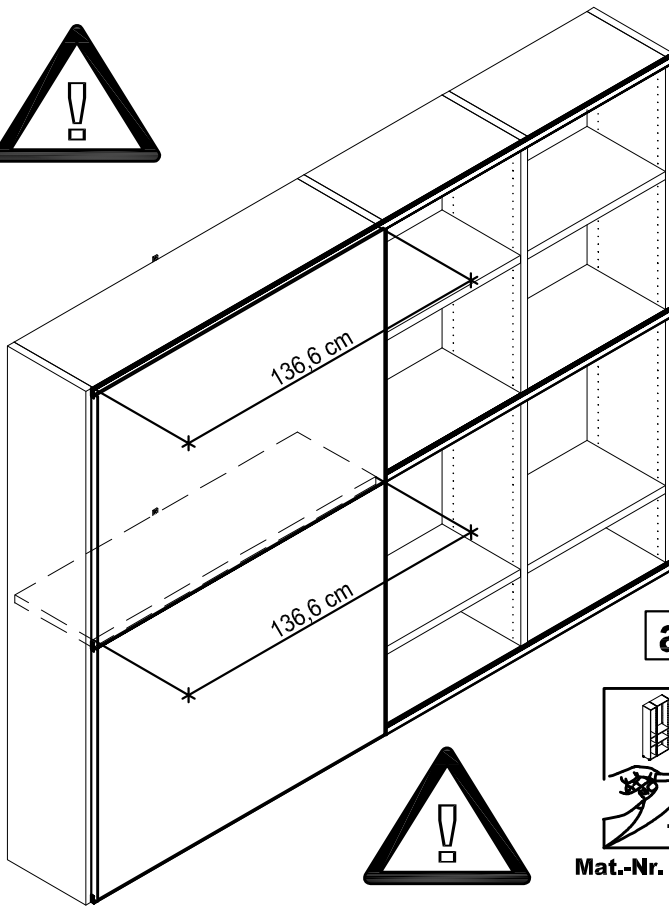
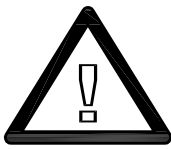

a



7-11  
Mat.-Nr. 1840420

2

Set 70er  
Set 140er



BB 2153

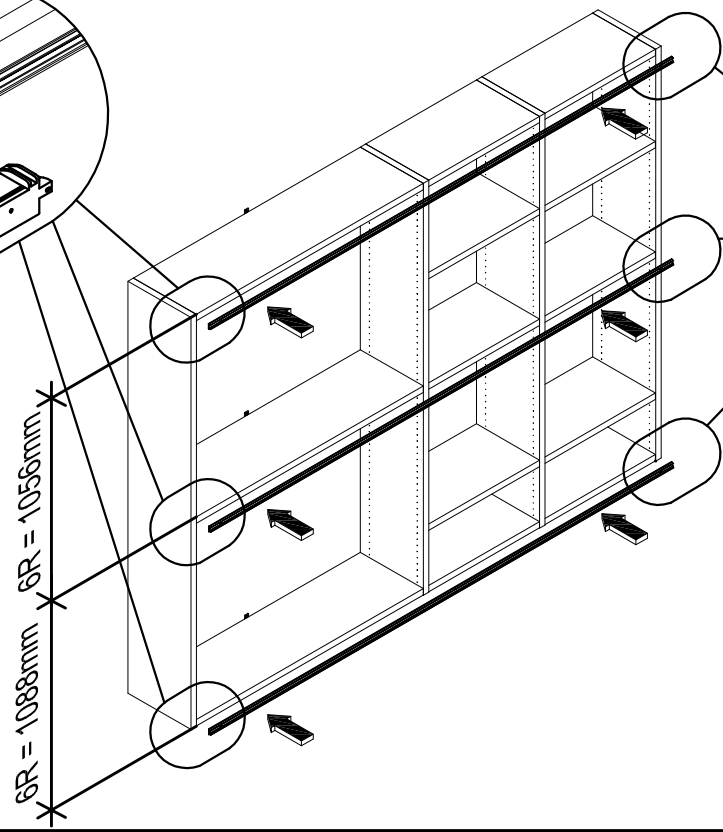
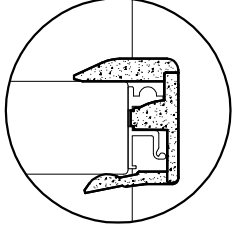
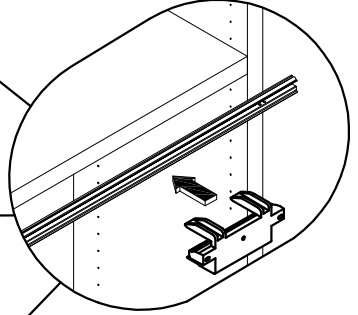
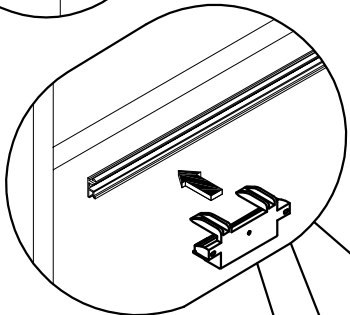
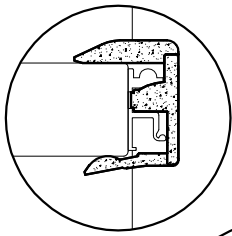
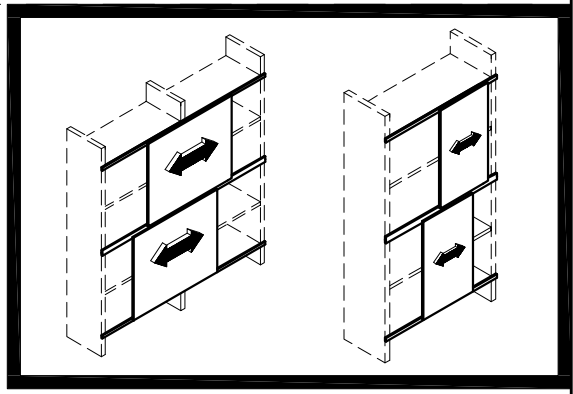

2

BB 2153

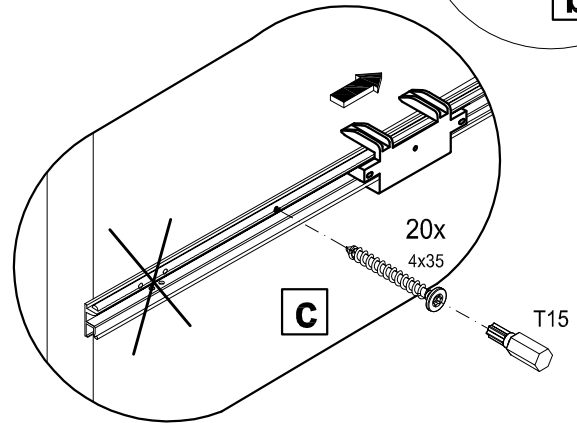
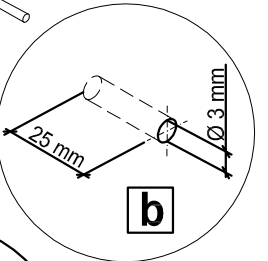
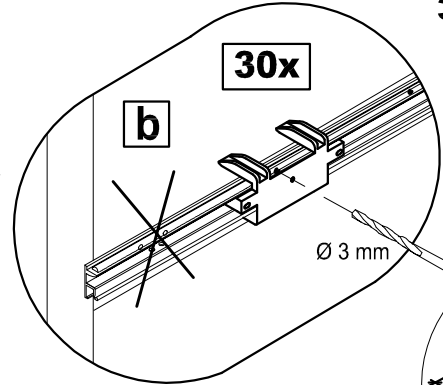
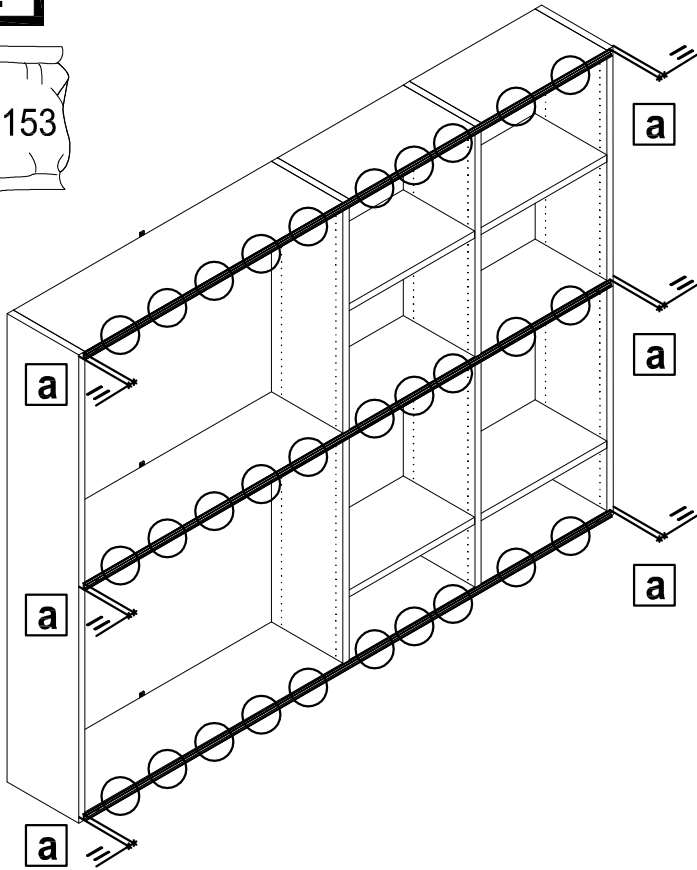

2

BB 2153

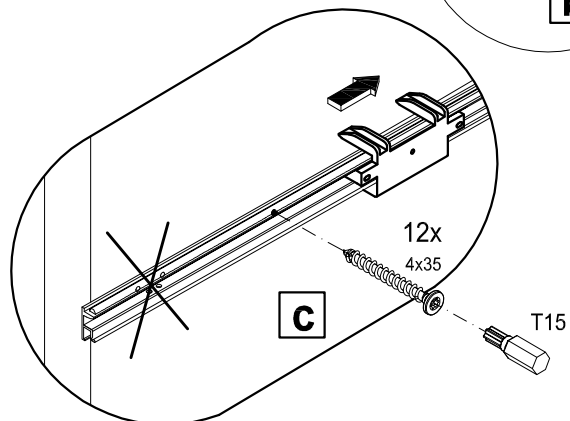
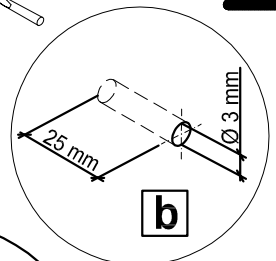
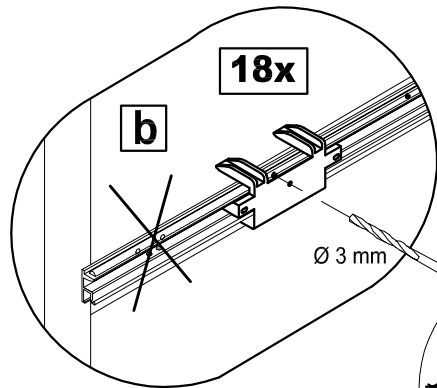
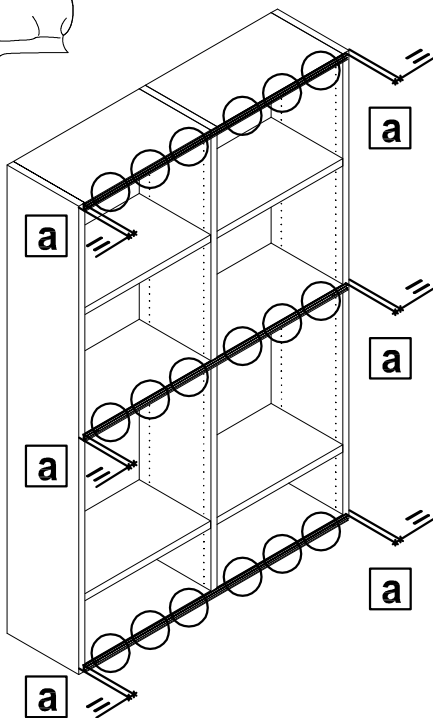

3

BB 2153

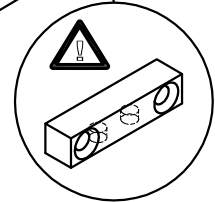
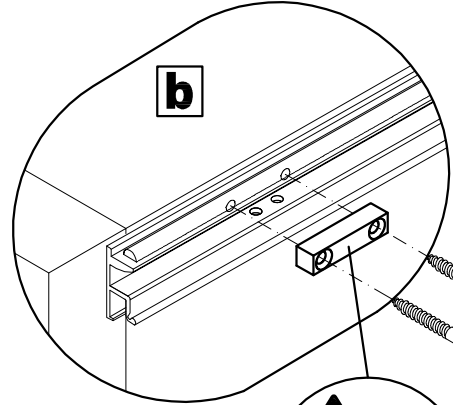
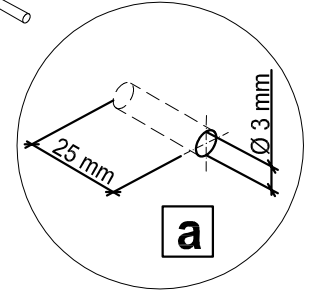
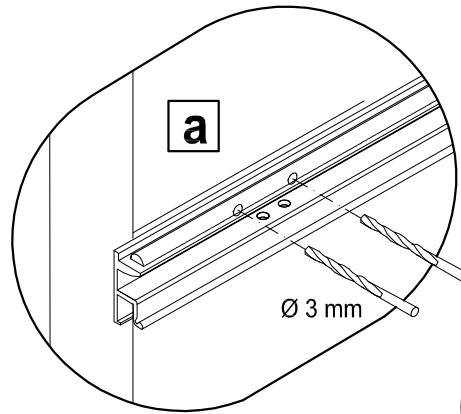
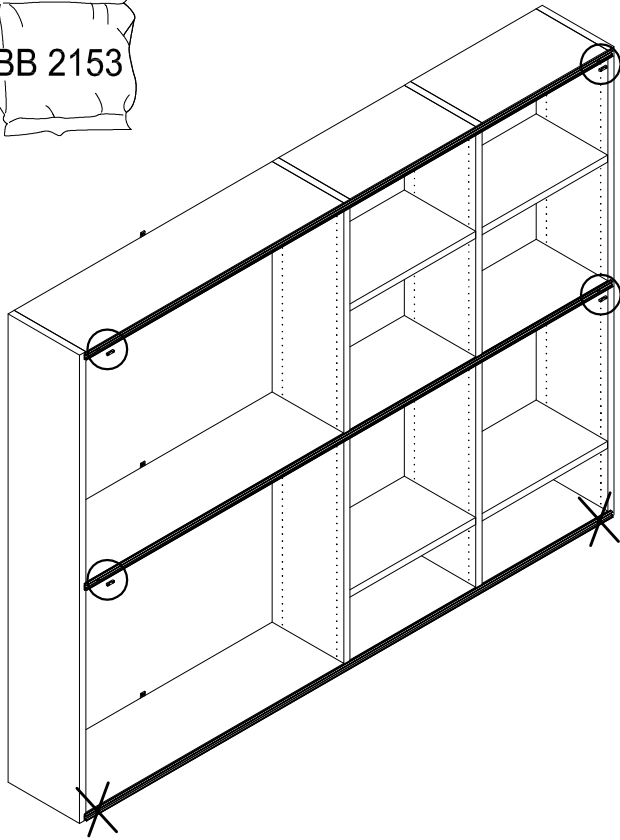

4

Set 70er  
Set 140er

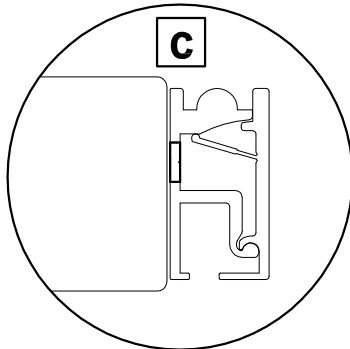
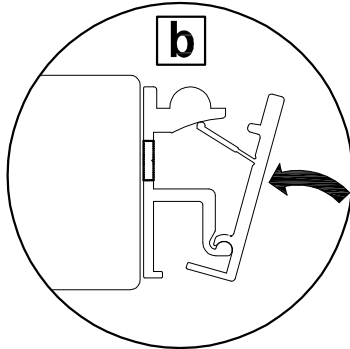
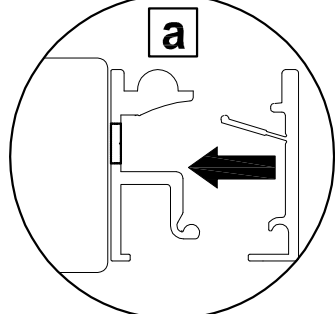
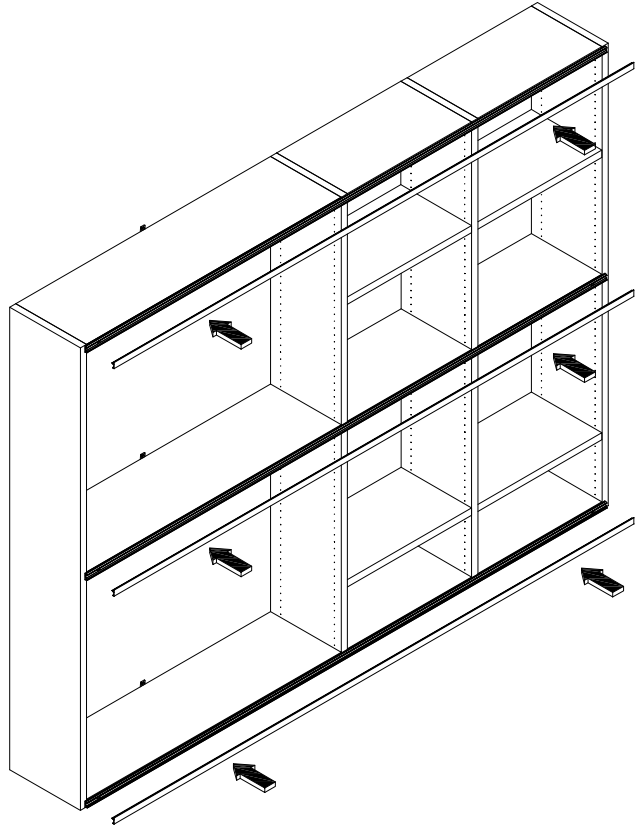

**5**

BB 2153

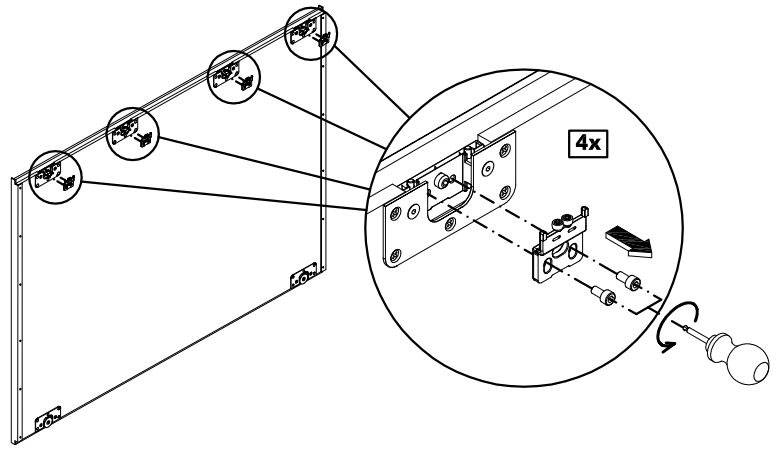
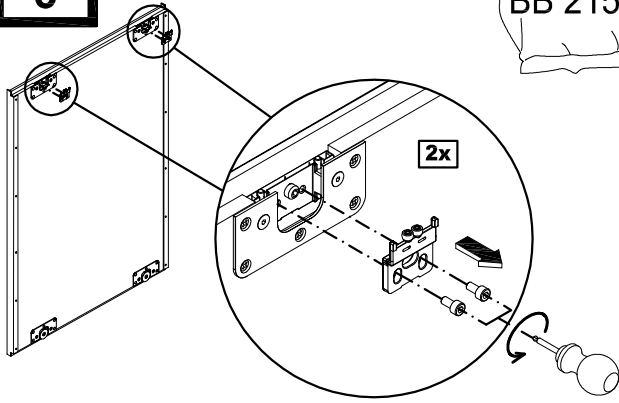

**6**

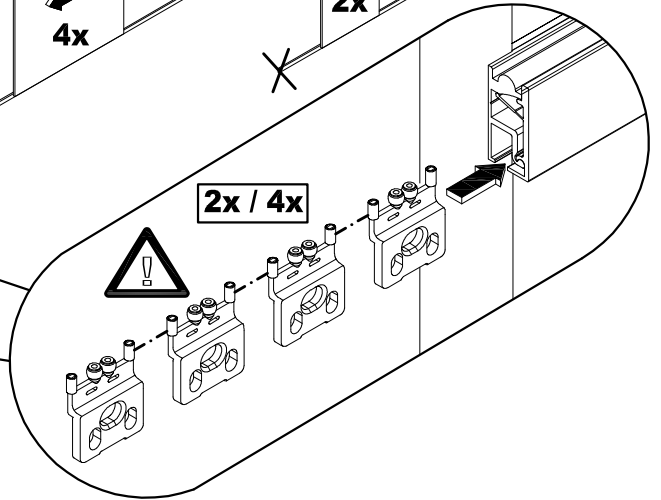
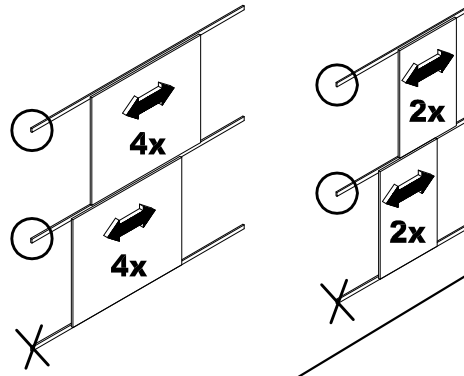
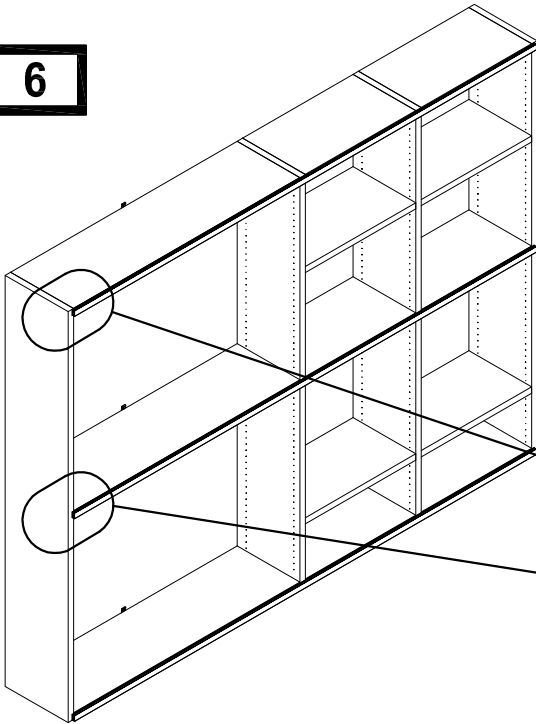

**7**

BB 2153

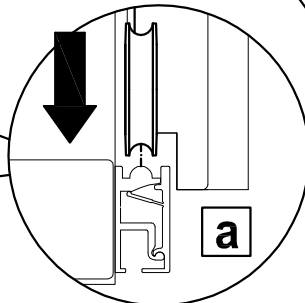
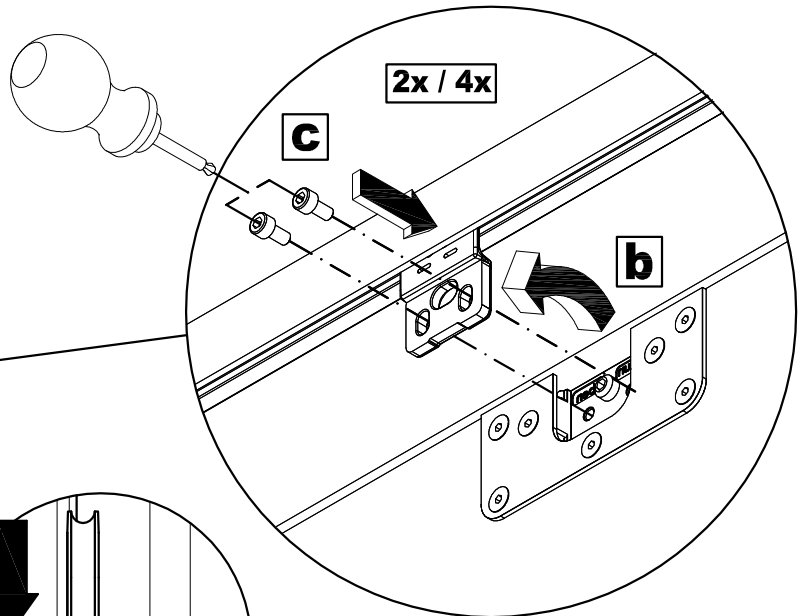
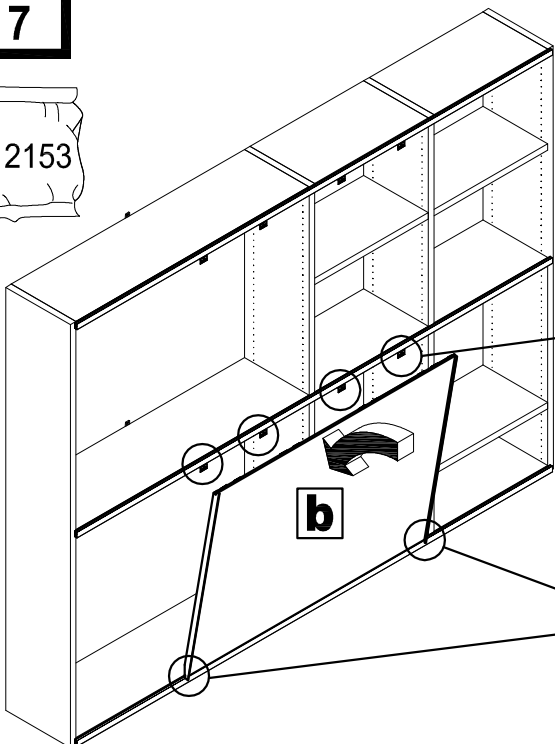

8

BB 2153

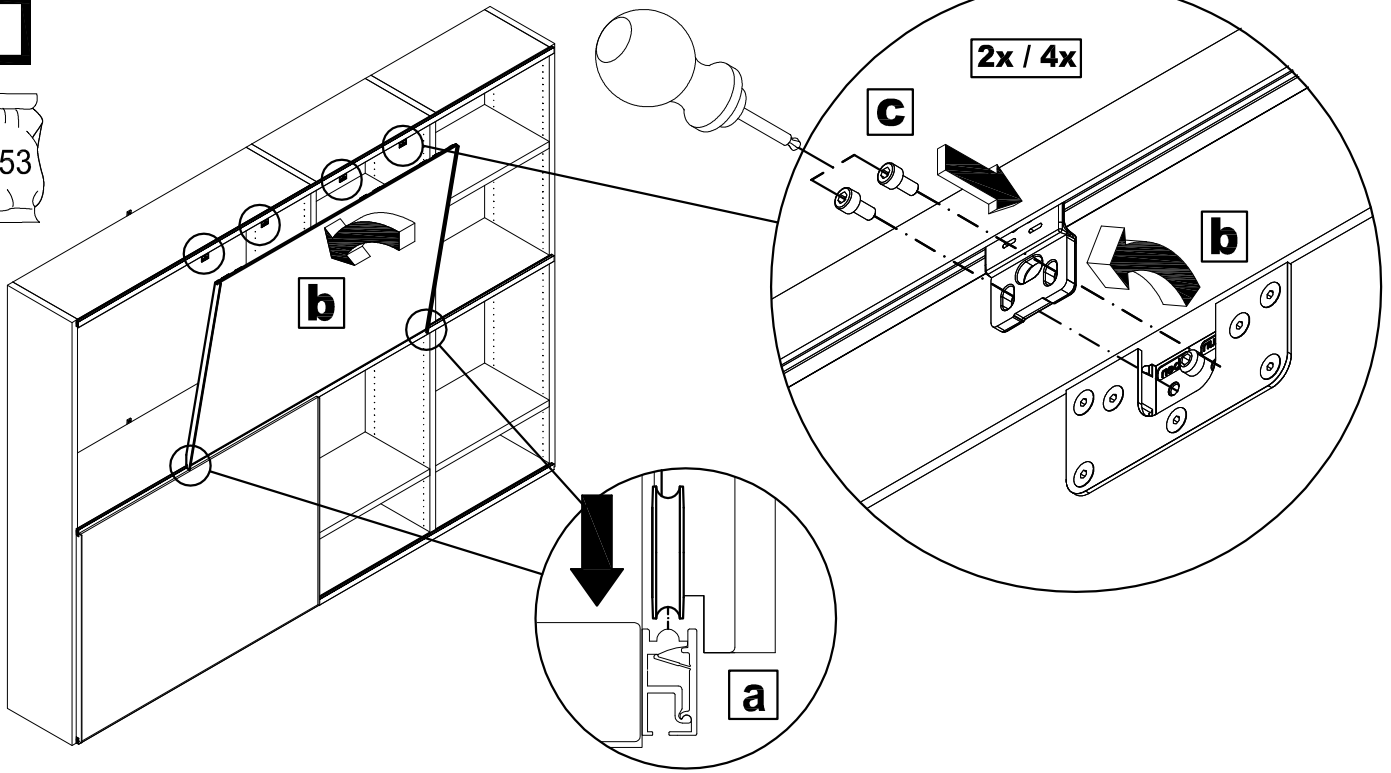

9

BB 2153

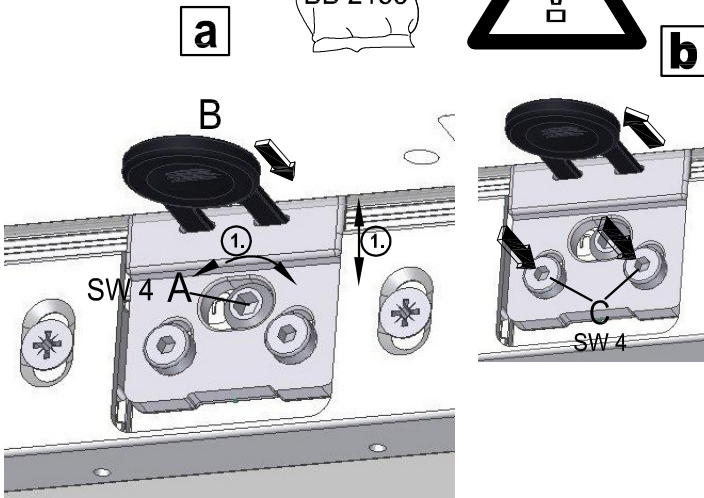
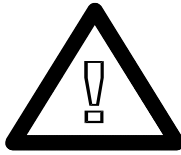

**Die Höheneinstellung über den gesamten Laufweg prüfen, eventuell die Ausrichtung des Möbels korrigieren.**

Check the height setting over the entire length of the rail, correct the unit settings if necessary.

*Le réglage en hauteur est à contrôler sur l'ensemble du trajet. Corriger éventuellement l'aplomb du meuble.*

Instelling van de hoogte over de gehele loop-traject controleren. Eventueel de waterpasstelling van het meubel corrigeren.

**Höheneinstellung des Führungsbeschlages über Excenter (A). Wenn die Einstellhilfe (B) an der Unterseite der Laufschiene anliegt, ist die optimale Einstellung erreicht! Schrauben (C) fest anziehen**

Height adjustment via excenter screw (A). The perfect setting is achieved when the adjuster aid (B) rests on the underside of the guiderail! Tighten screws (C) firmly.

*Réglage en hauteur de la ferrure de guidage à l'aide de l'excentrique (A). Le réglage optimal est obtenu lorsque la pièce pour l'aide au montage (B) repose sur la face inférieure du rail!*

*Serrer les vis (C).*

Instelling van de hoogte van het geleidingsbeslag via excenter (A). Als de instelhulp (B) vlak tegen de onderkant van de rail ligt, is de optimale instelling bereikt! Schroeven (C) vastdraaien.

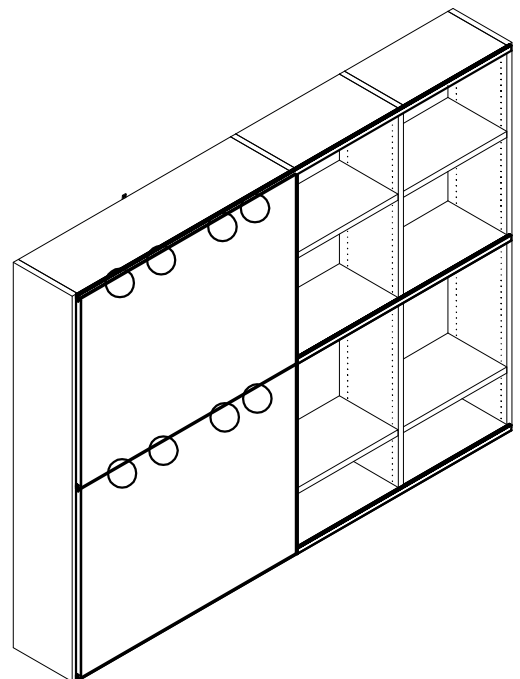

10

BB 2153

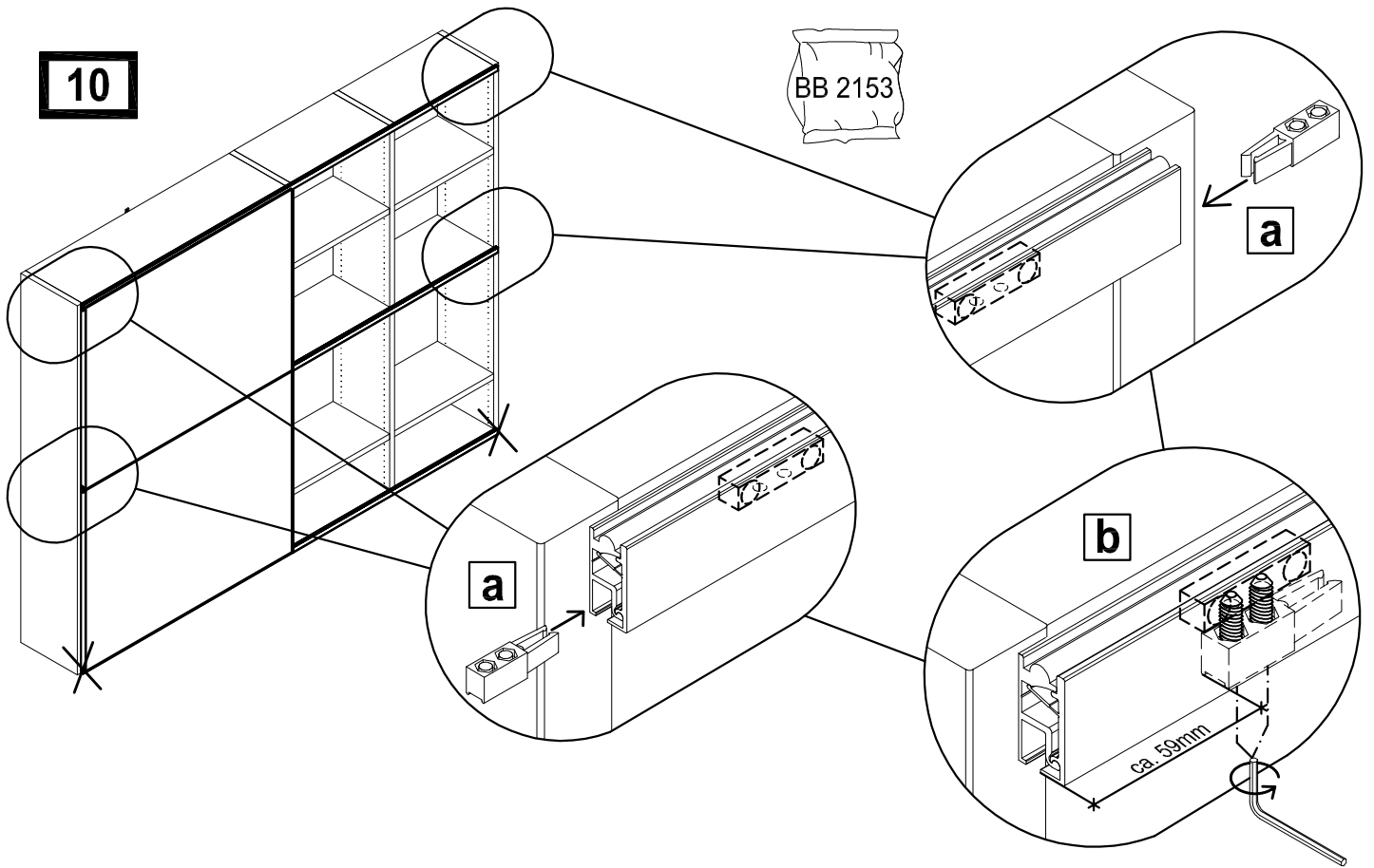

**Gewindeschrauben des Stoppers in Anschlaghalterung mit 5-6 Umdrehungen eindrehen.**

Screw the threaded screws of the stopper into the stop holder by turning them 5-6 times.

*Effectuez 5-6 tours de la vis filetée de l'arrêt dans le support de butée.*  
Draai de schroeven van stopper 5-6 rotaties in aanslaghouder.

11

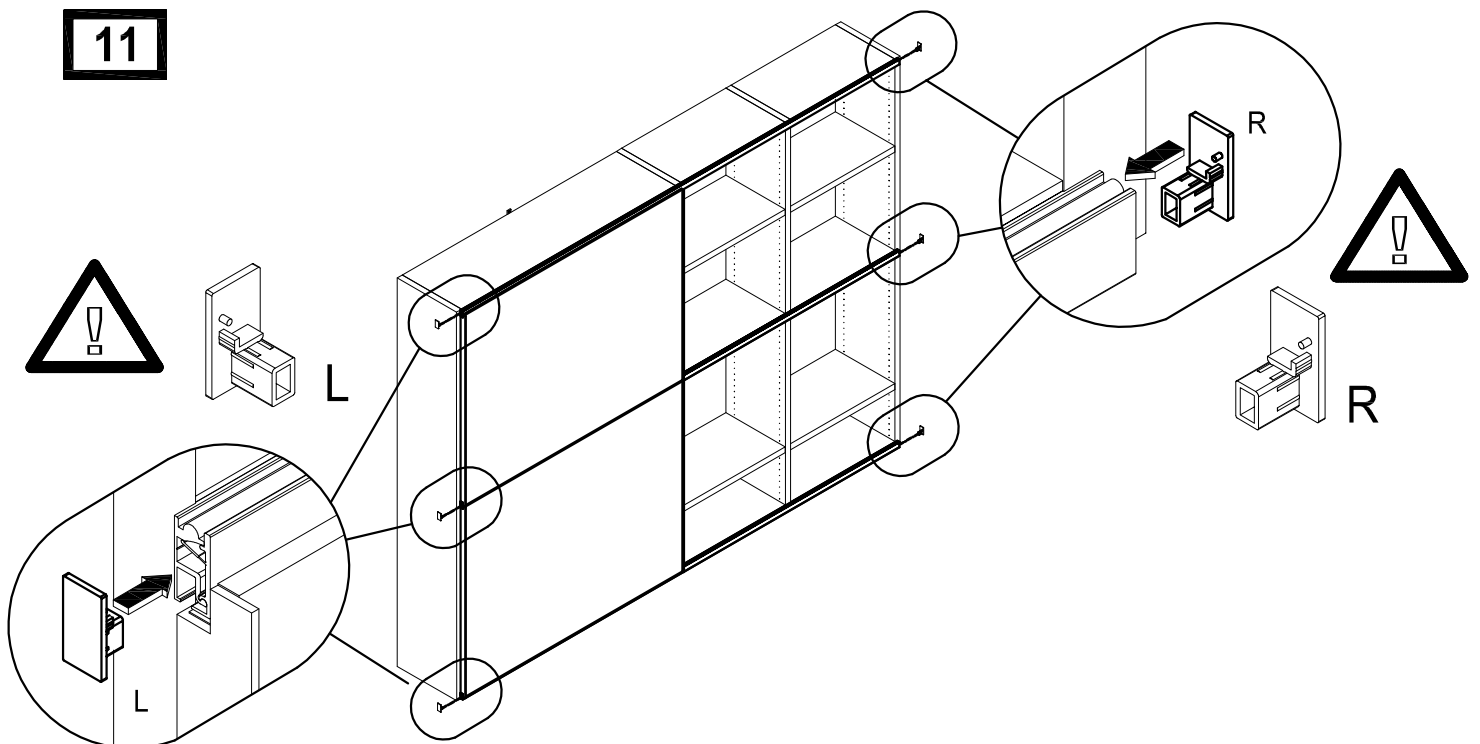



12

BB 2153  
Set 140er

