

Wichtige Kundeninformation zum Verbleib beim Endkunden

Important customer information
Information client important à conserver
Belangrijke informatie voor de klant

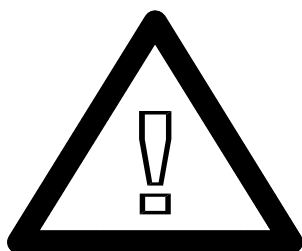

WASCHANLEITUNG STOFFKLAPPE

WASHING INSTRUCTIONS FOR FABRIC FLAP
NOTICE D'ENTRETIEN DE L'ABATTANT EN TISSU
WASINSTRUCTIES STOFKLEP

hülsta 

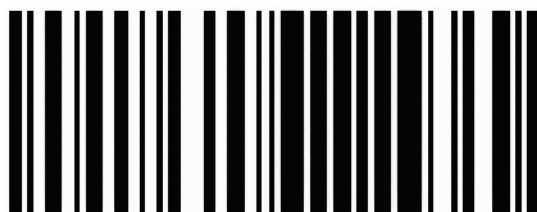

1565187

Demontage Stoffklappe

Dismantling of fabric flap

Démontage abattant en tissu

Demontage stofklep

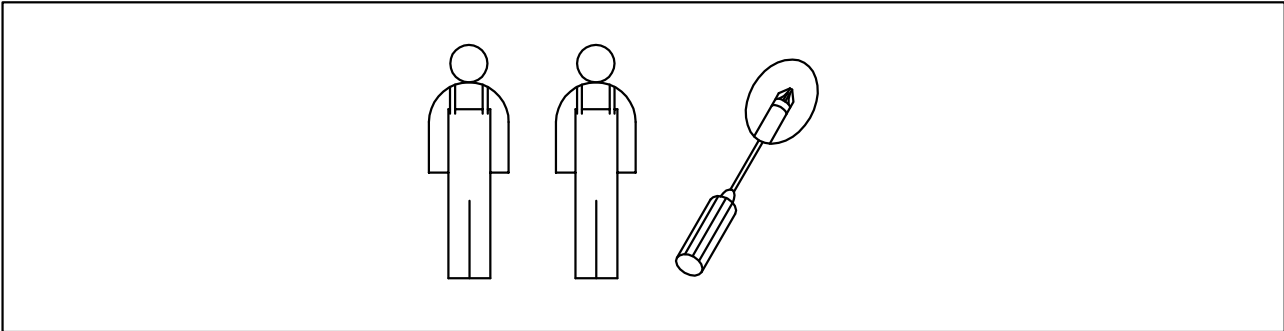

1

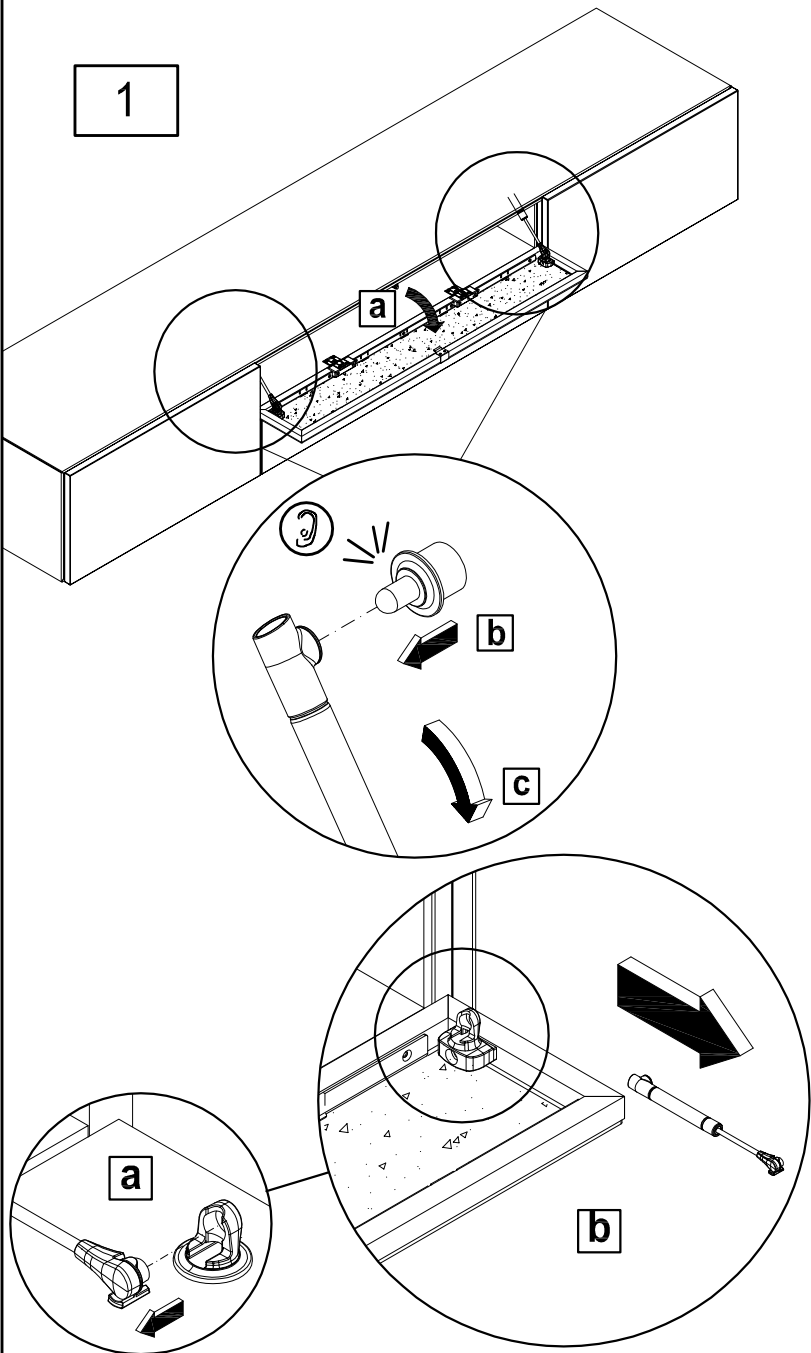

Achtung,
Verletzungsgefahr, da
das Seil unter einer
großen Zugkraft steht.
Attention. Risk of injury as
rope is under a lot of
pressure
Attention. Danger de
blessures, car le câble est
sous une tension
importante.
Attentie! blessuregevaar,
op de kabel staat een
grote trekkracht

2

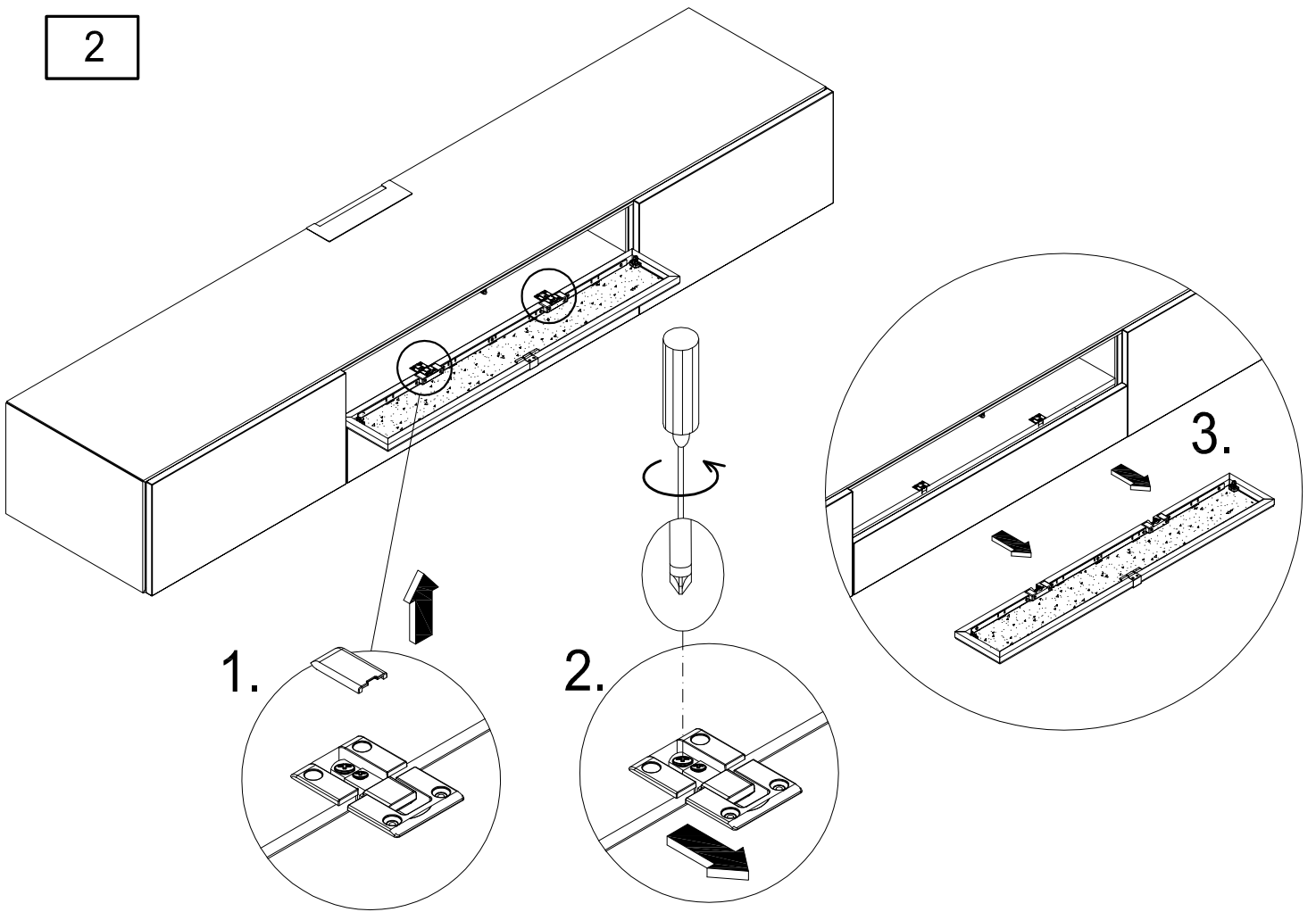

3

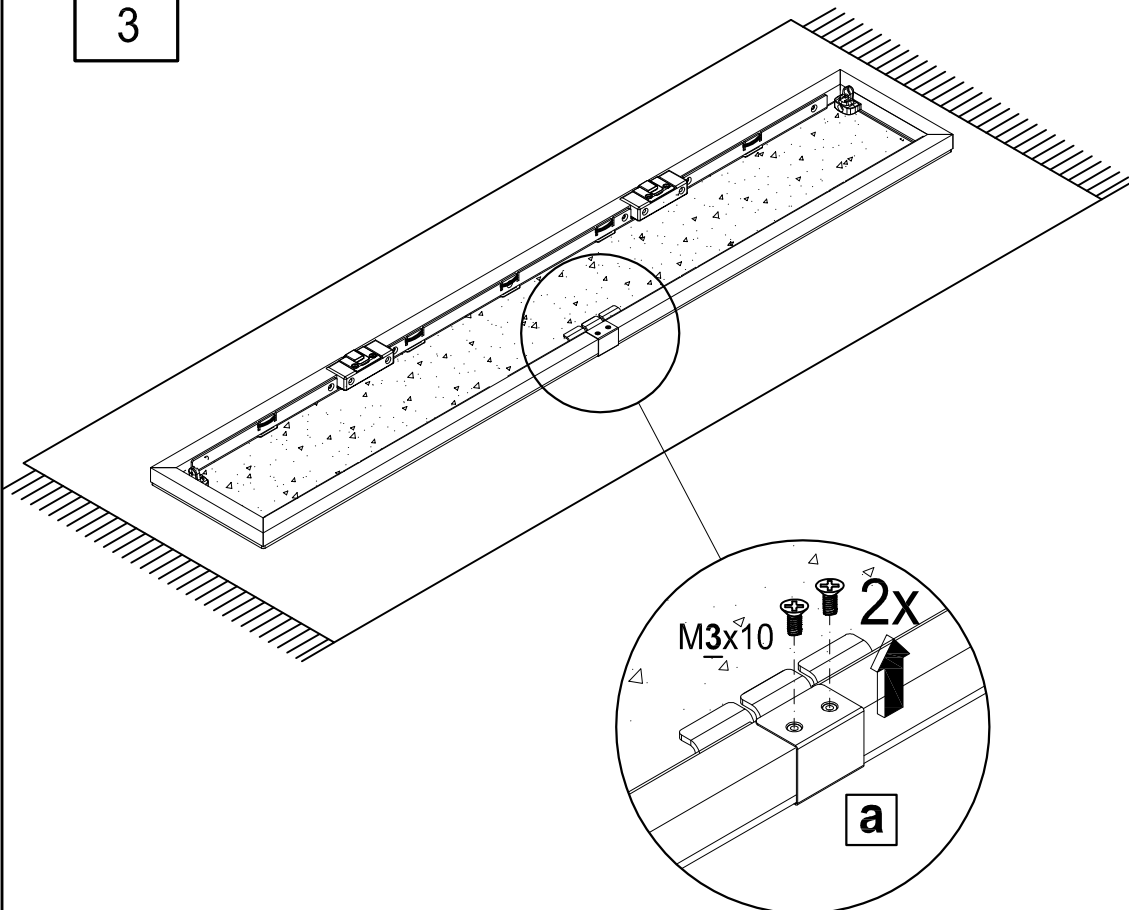

die "glänzende Seite" des Stoffes ist aussen (Sichtseite)

Turn "glossy side" of fabric is outside (visible side)

La « face brillante » du tissu vers l'extérieur (face visible)

De "glanzende kant" van de stof is buiten (in het zicht)

4

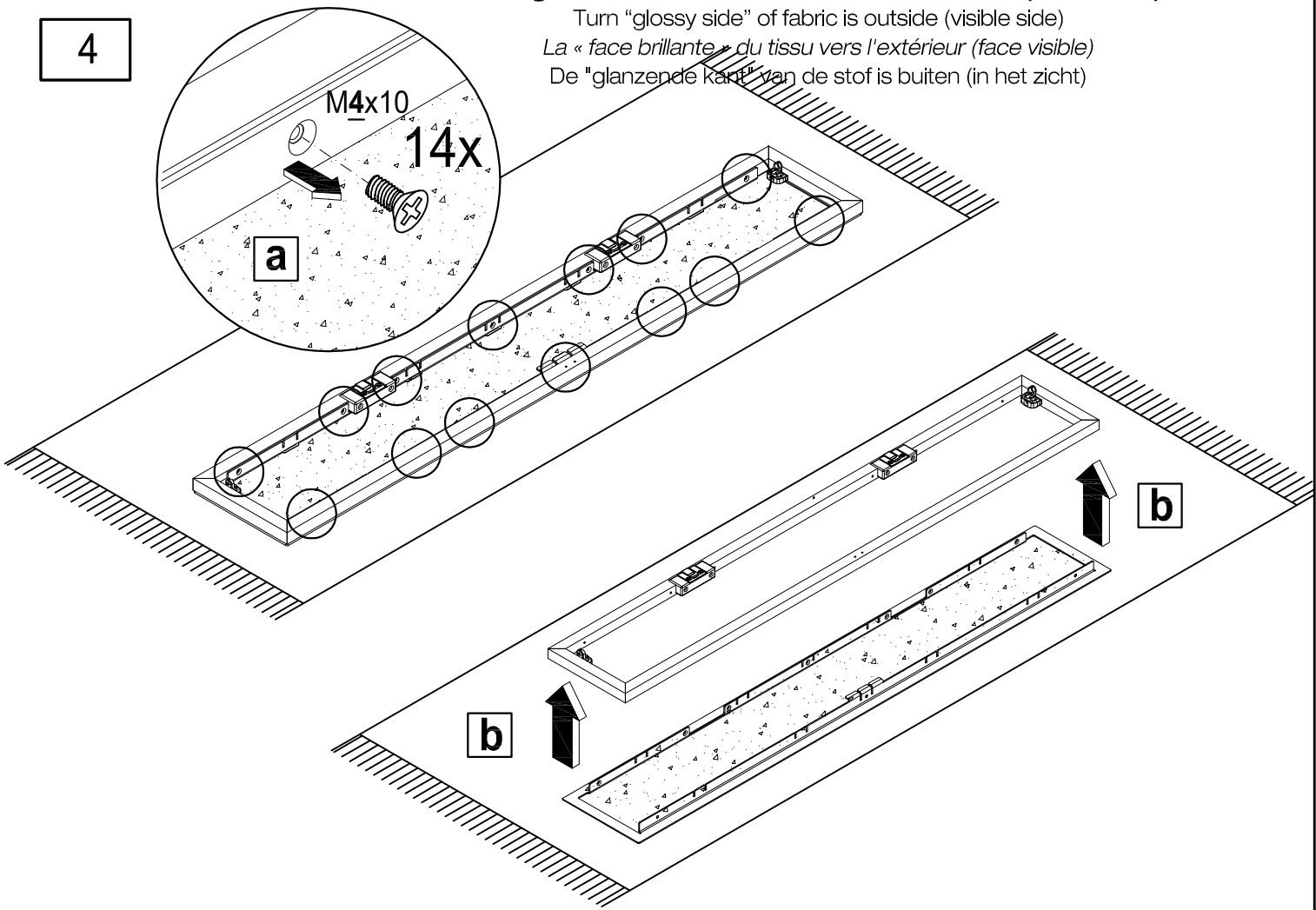

5

