

Montageanleitung

Assembly instruction

Notice de montage

Montagehandleiding

LED-

Leuchtmittelwechsel

Exchanging LED

Echange du LED

Vervangen van een LED

hülsta 



1352593

MONTAGEANLEITUNG



Assembly instruction
Notice de montage
Montagehandleiding

INHALT · CONTENTS · TABLE DES MATIERS · INHOUD

Programm Range · Programme · Programma	Type Type · Version · Type
ELEA	Winkelborde mit Ablagefläche aus Glas 3-9 Type 254 / 214 / 264 Right-angled shelves with glass shelf · <i>Tablettes en équerre avec surface de desserte en verre</i> · Gehoekte boekenplanken met glazen legger
ACREA	Winkelborde mit Ablagefläche aus Glas 3-9 Type 254 / 274 / 214 / 264 Right-angled shelves with glass shelf · <i>Tablettes en équerre avec surface de desserte en verre</i> · Gehoekte boekenplanken met glazen legger
METIS PLUS	Winkelborde mit Ablagefläche aus Glas 3-9 Type 50501 / 50701 / 51201 Right-angled shelves with glass shelf · <i>Tablettes en équerre avec surface de desserte en verre</i> · Gehoekte boekenplanken met glazen legger
CUTARO	Winkelborde mit Ablagefläche aus Glas 3-9 Type 5051 / 5071 / 5121 / 5161 Right-angled shelves with glass shelf · <i>Tablettes en équerre avec surface de desserte en verre</i> · Gehoekte boekenplanken met glazen legger

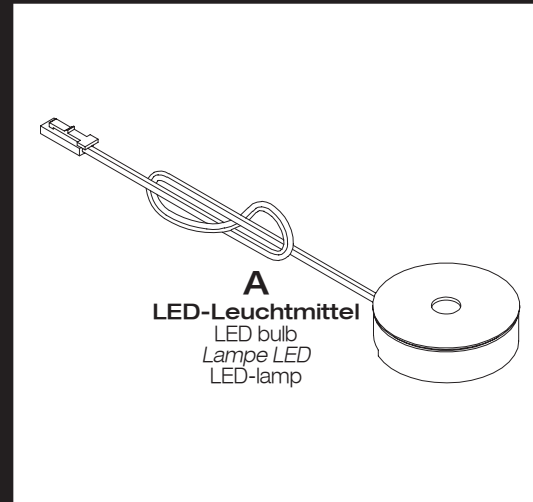
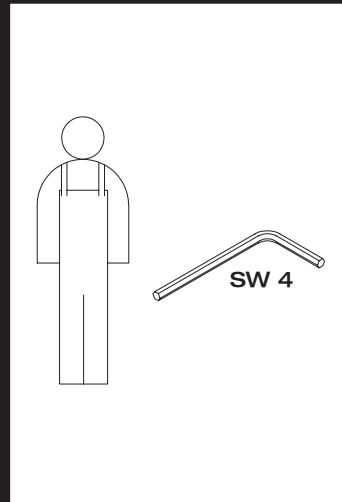
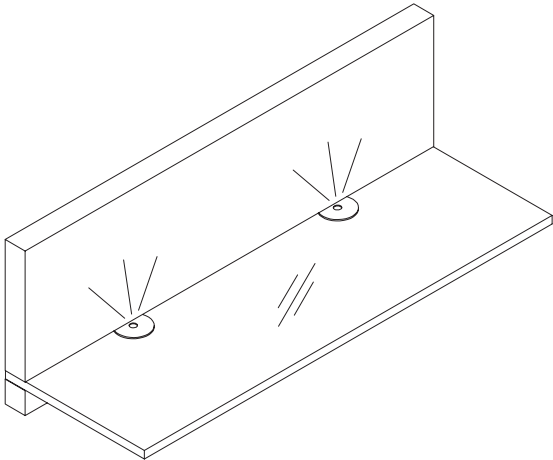

1

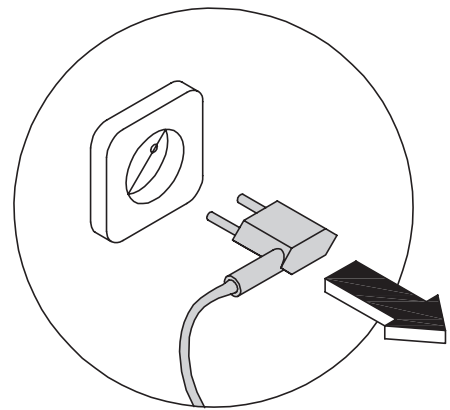
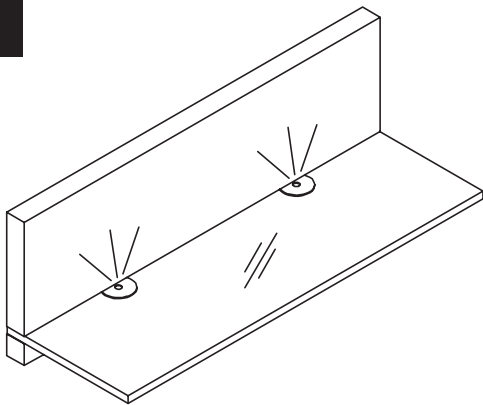

2

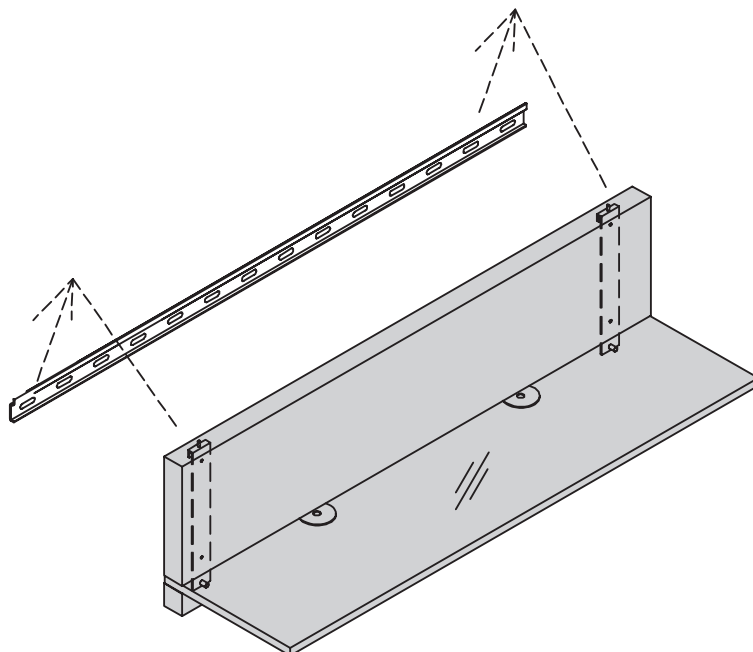

MONTAGEANLEITUNG

hülsta 

WINKELBORD MIT ABLAGEFLÄCHE AUS GLAS

RIGHT-ANGLED SHELVES WITH GLASS SHELF
TABLETTES EN EQUERRE AVEC SURFACE DE DESSERT EN VERRE
GEHOEKTE BOEKENPLANKEN MET GLAZEN LEGGER

LEUCHTMITTELWECHSEL · EXCHANGING TUBE · ECHANGE DU TUBE · VERVANGEN VAN EEN LAMP

3

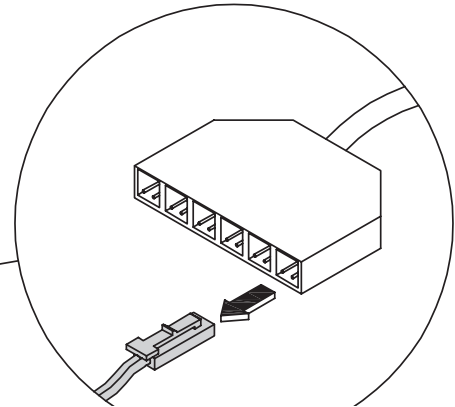
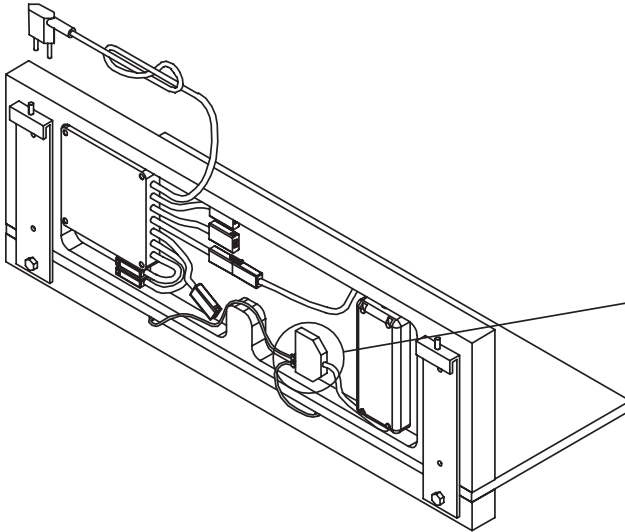

Defektes Leuchtmittel ausstecken!
Detach defective bulb
Extraire la lampe défectueuse
Defecte lamp loskoppelen

4

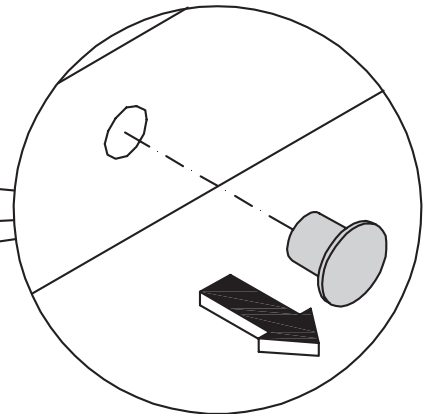
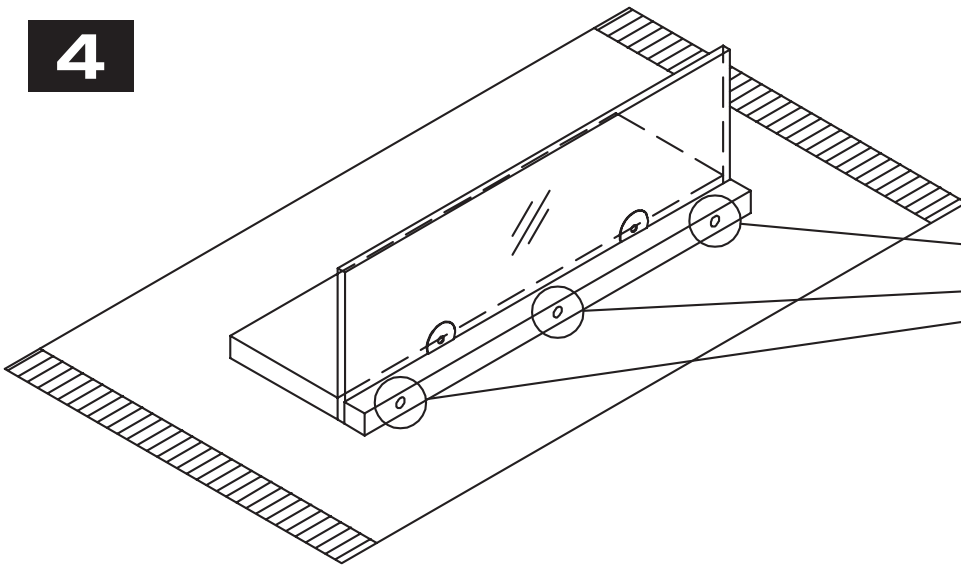

5

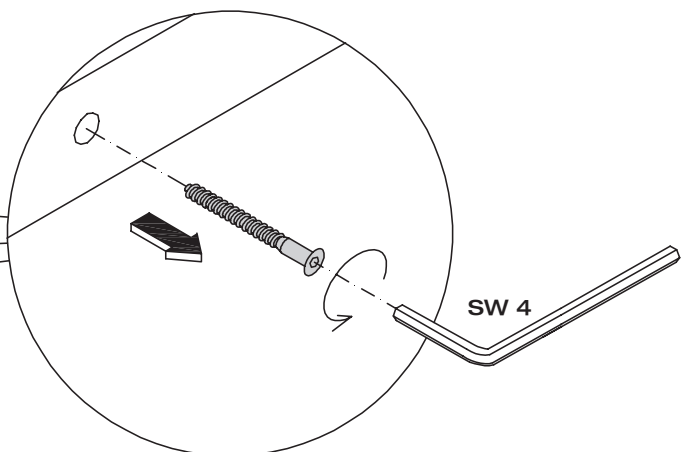
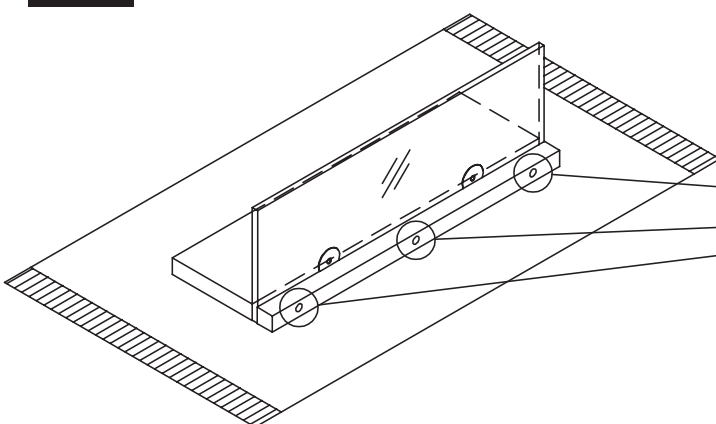

6

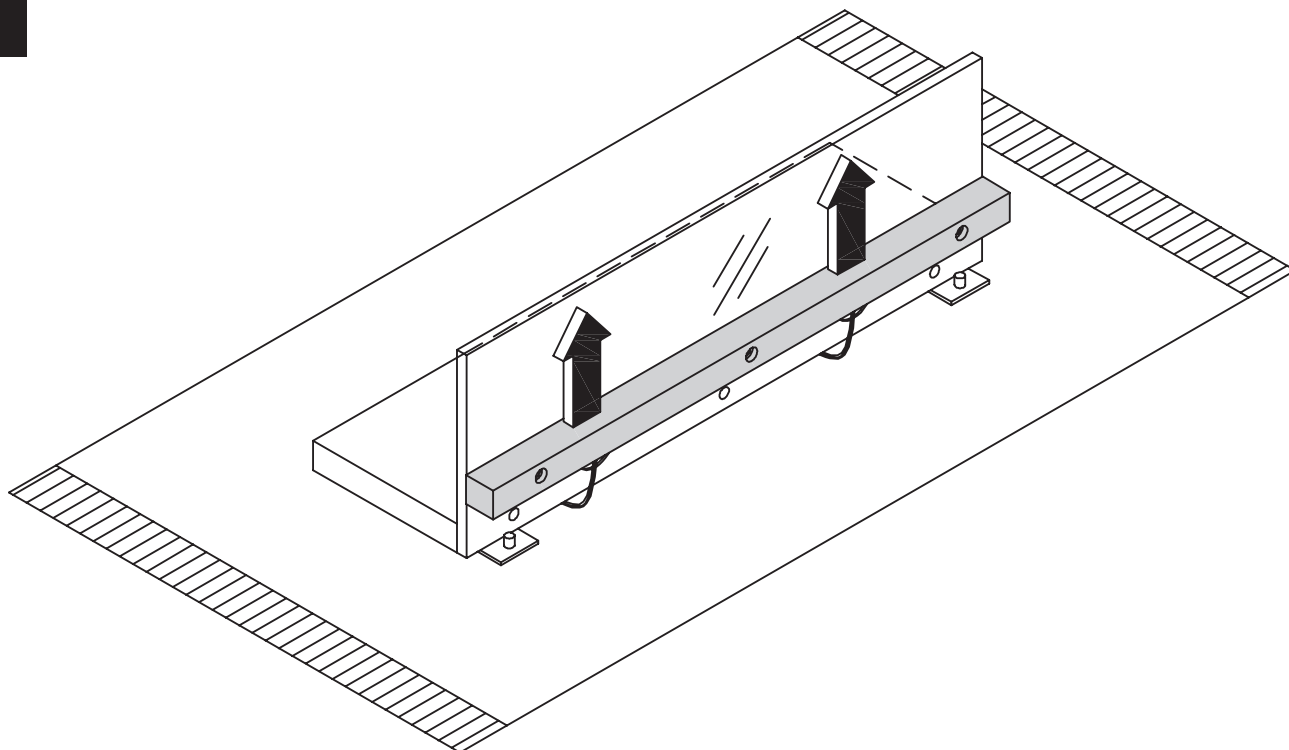

7

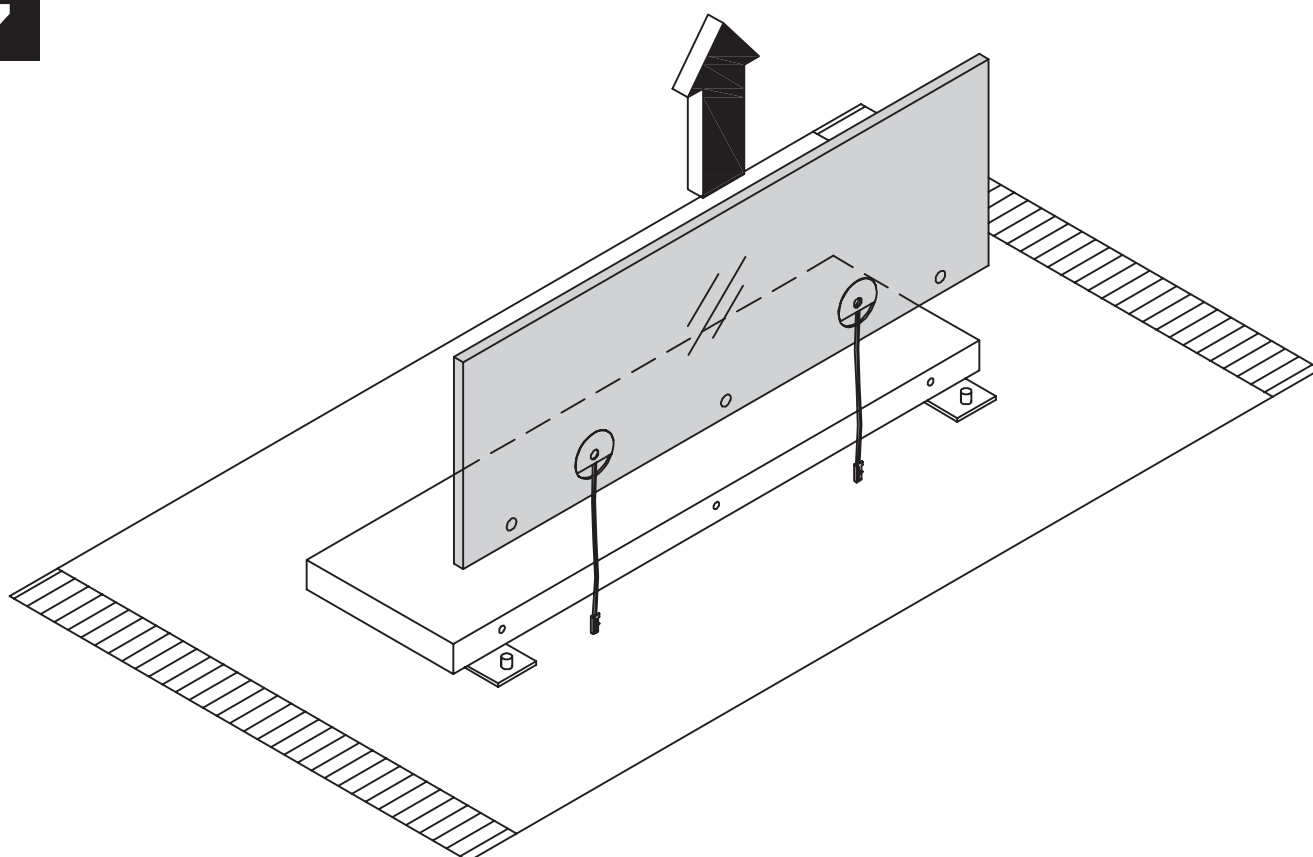

MONTAGEANLEITUNG



WINKELBORD MIT ABLAGEFLÄCHE AUS GLAS

RIGHT-ANGLED SHELVES WITH GLASS SHELF
TABLETTES EN EQUERRE AVEC SURFACE DE DESSERT EN VERRE
GEHOEKTE BOEKENPLANKEN MET GLAZEN LEGGER

LEUCHTMITTELWECHSEL · EXCHANGING TUBE · ECHANGE DU TUBE · VERVANGEN VAN EEN LAMP

8

Defektes Leuchtmittel entfernen

Remove defective bulb
Retirer la lampe défectueuse
Defecte lamp verwijderen

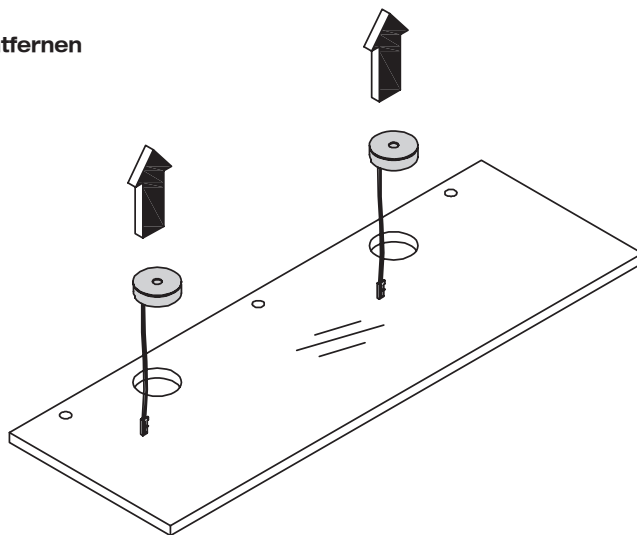

9

Neues Leuchtmittel einlegen!

Insert new bulb
Mettre en place la nouvelle lampe
Nieuwe lamp plaatsen

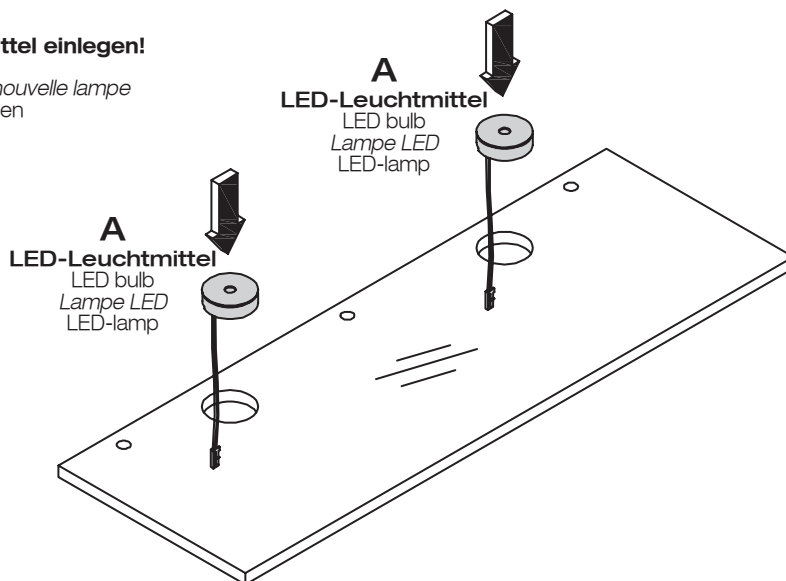

10

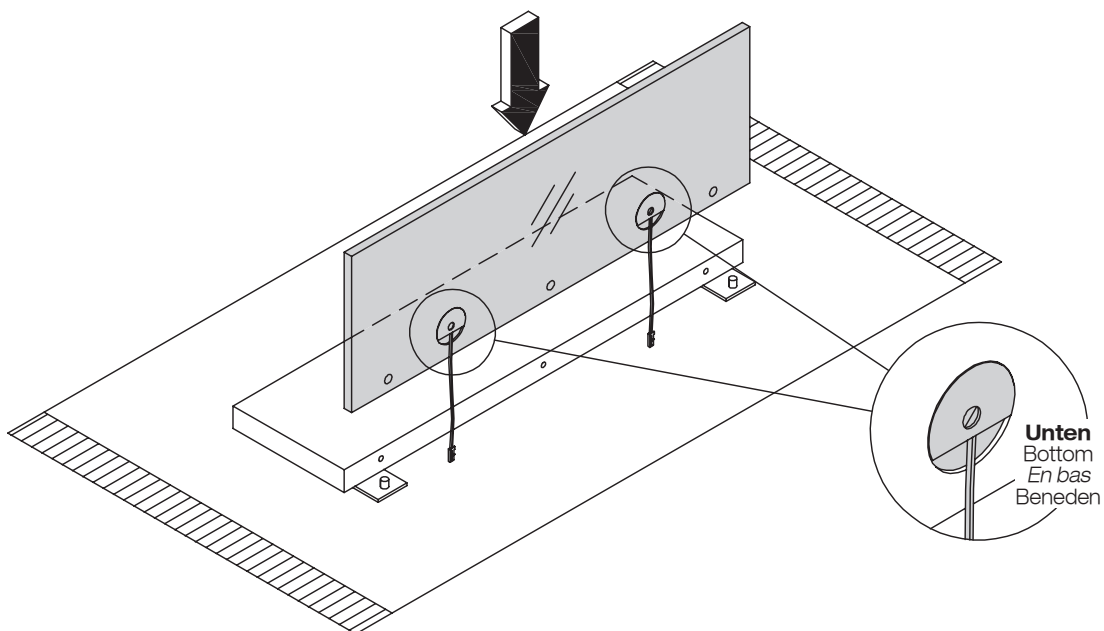

11

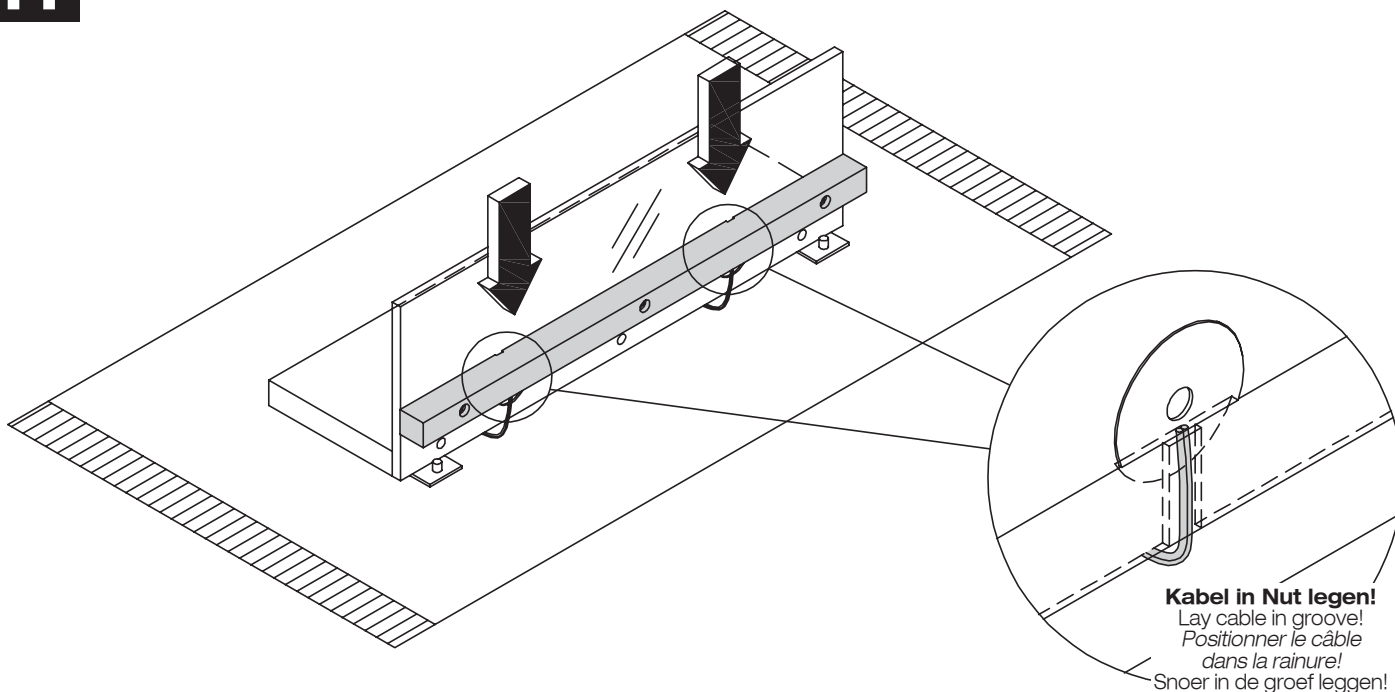

12

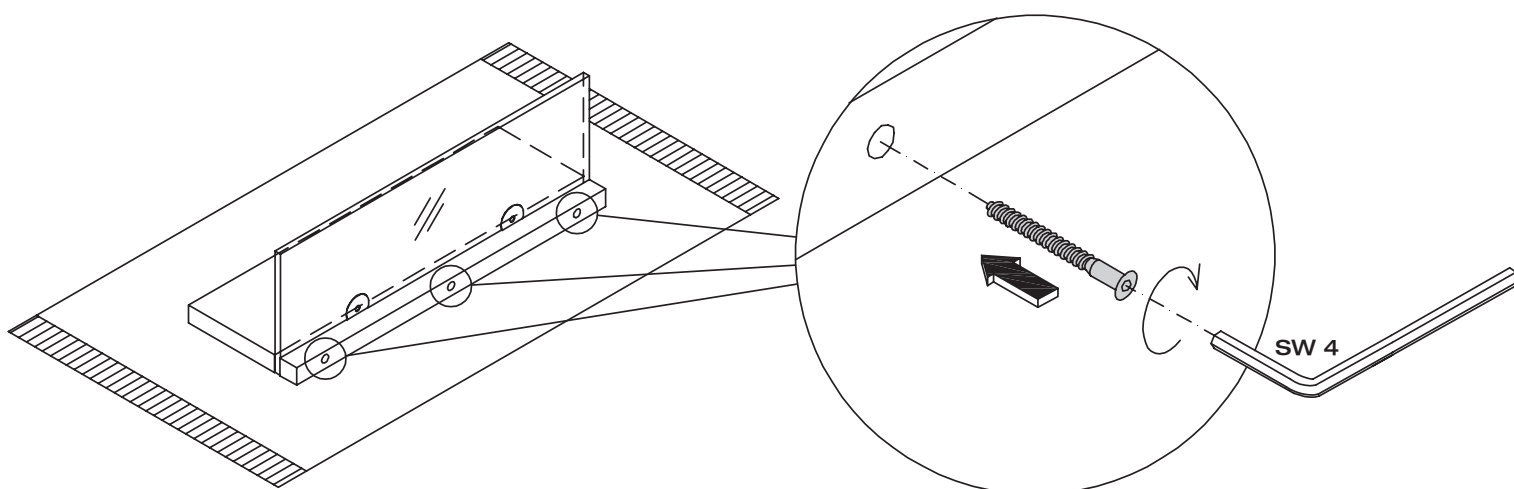

MONTAGEANLEITUNG

hülsta

WINKELBORD MIT ABLAGEFLÄCHE AUS GLAS

RIGHT-ANGLED SHELVES WITH GLASS SHELF
TABLETTES EN EQUERRE AVEC SURFACE DE DESSERT EN VERRE
GEHOEKTE BOEKENPLANKEN MET GLAZEN LEGGER

LEUCHTMITTELWECHSEL · EXCHANGING TUBE · ECHANGE DU TUBE · VERVANGEN VAN EEN LAMP

13

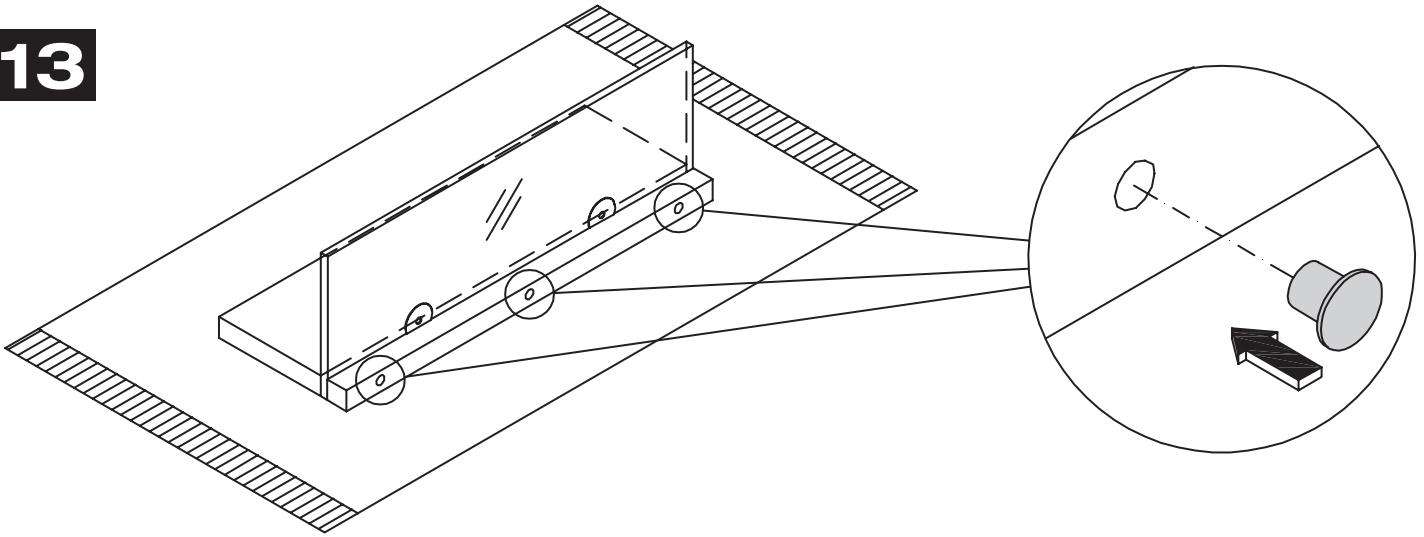

14

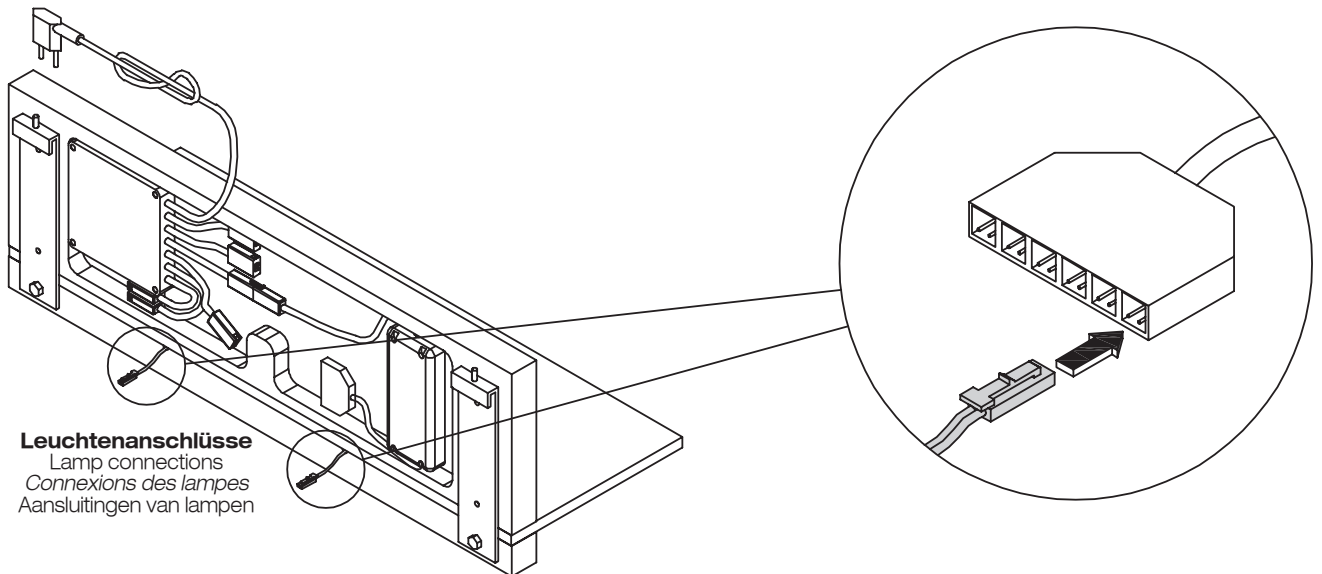

15

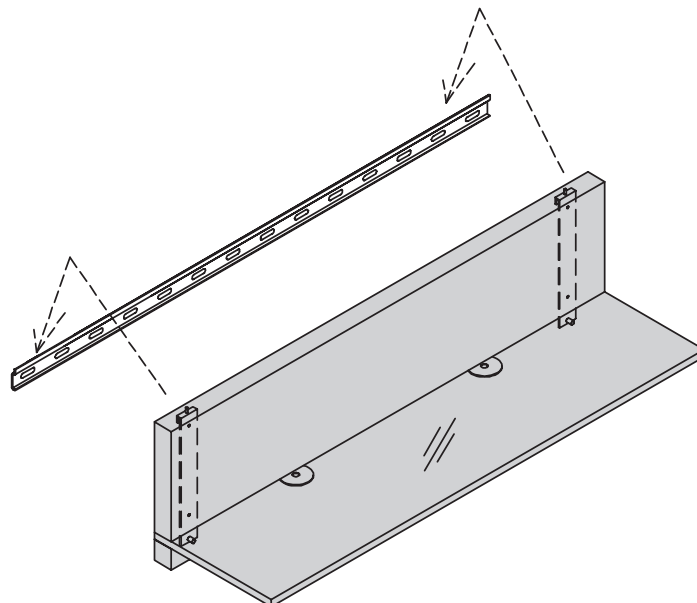

16

