



# MONTAGEANLEITUNG Innenschubkästen

Inside drawers  
Tiroirs intérieurs  
Binnenladen



MONTAGEANLEITUNG · ASSEMBLY INSTRUCTION · NOTICE DE MONTAGE · MONTAGEHANDLEIDING

**Hinweis: Vor Schubkastenmontage die Schiebetür einbauen!**

Note: Fit sliding-door before fitting the drawer!

Remarque: Veuillez monter la porte coulissante avant le montage des tiroirs!

N.B.! Voor het monteren van de lade, de schuifdeur aanbrengen!

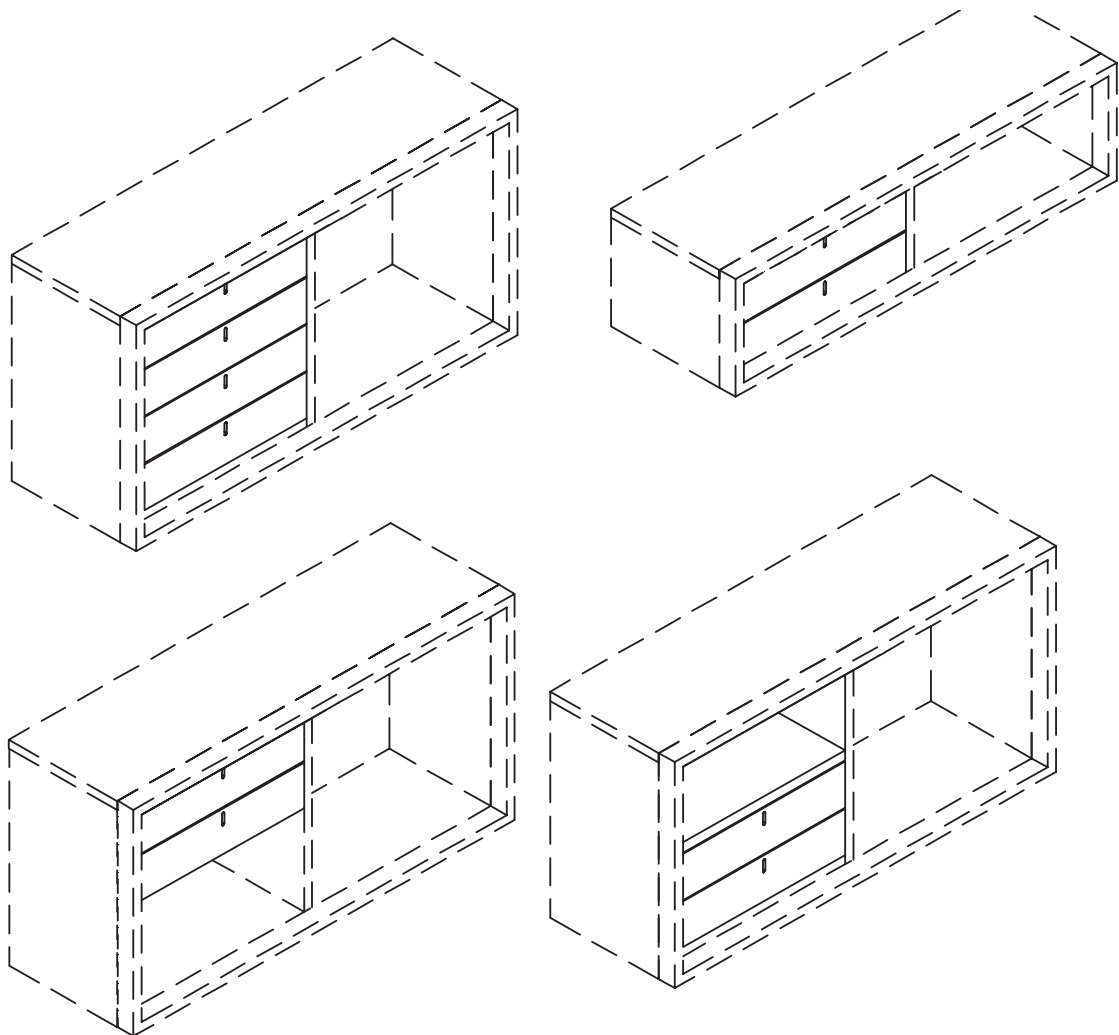

1221337

**Lesen Sie zuerst die Anleitung und beginnen Sie dann mit der Montage**

Before starting with the fitting, please read carefully the assembly instruction

Avant de commencer avec le montage, nous vous prions de bien lire le notice de montage

Voordat uw met de montage begint, a.u.b. de montagehandleiding lezen

# MONTAGEANLEITUNG Innenschubkästen

Inside drawers  
Tiroirs intérieurs  
Binnenladen

**now!**  
by hülsta

## GESAMTÜBERSICHT · SUMMARY · VUE GENERALE · TOTAALOVERZICHT

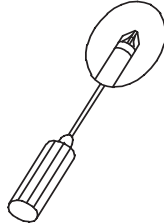
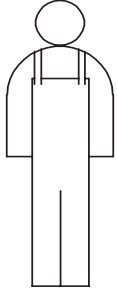

### Für die Montage wird benötigt:

Necessary for assembly:

Pour le montage il faut:

Benodigdheden voor de montage:

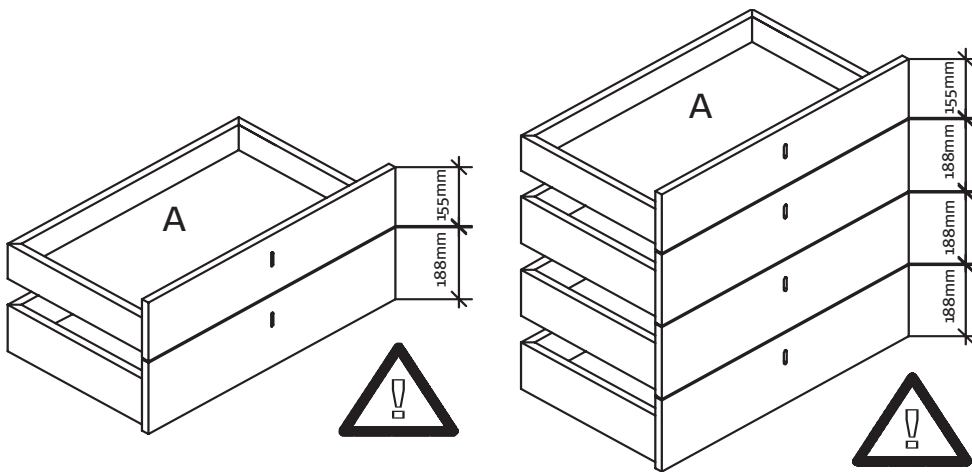

B (1x-4x)

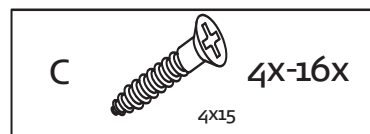
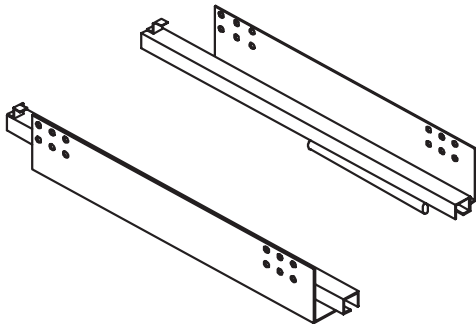

### Beschlagbeutel now! 1070

Mat.-Nr.: 119710

Accessories bag now! 1070

Sachets de ferrures now! 1070

Zakjes met beslagdelen now! 1070

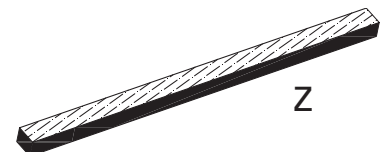
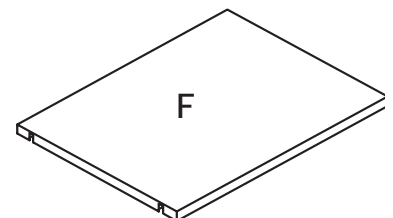
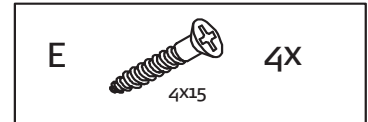
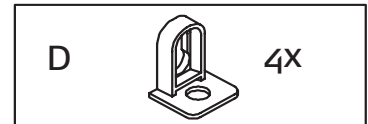

### Verehrter Kunde, hier haben Sie die Möglichkeit die mitgelieferten Schrauben nachzumessen!

Dear customer, here you find a possibility  
to measure the delivered screws!

*Cher client, ici vous avez la possibilité  
de mesurer les vis livrées!*

Beste klant, hier heeft uw de mogelijkheid  
de schroeven te meten!



# MONTAGEANLEITUNG Innenschubkästen

Inside drawers  
Tiroirs intérieurs  
Binnenladen

**now!**  
by hülsta

MONTAGE · ASSEMBLY · MONTAGE · MONTAGE

## linke Schubkastenseite

Left drawer rail  
Rail gauche du tiroir  
Linker Ladeloper

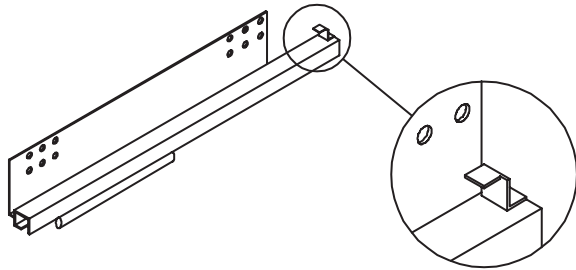

## rechte Schubkastenseite

Right drawer rail  
Rail droit du tiroir  
Rechter Ladeloper

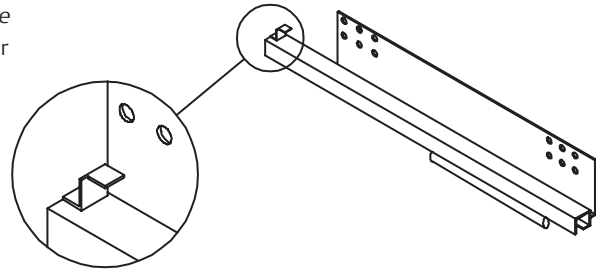

## Hinten

Rear  
Arrière  
Achter

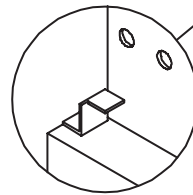

1

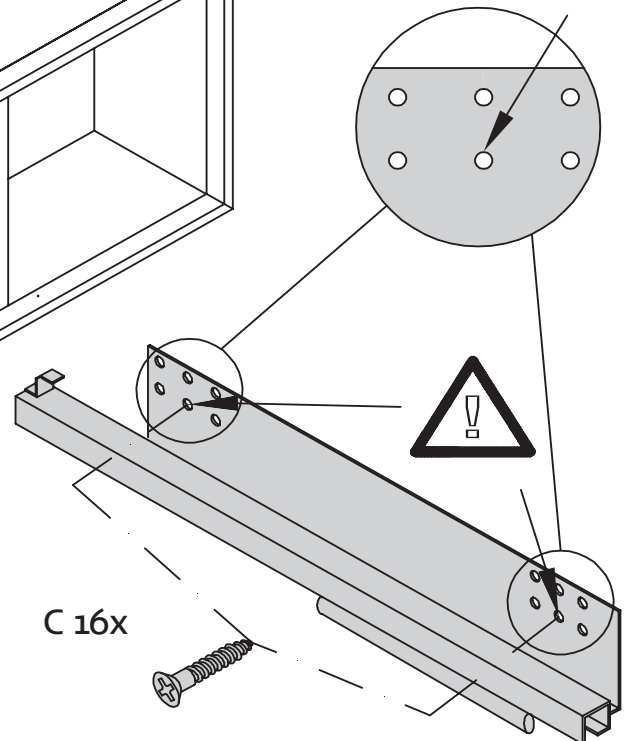
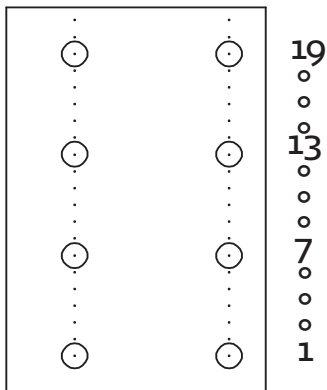
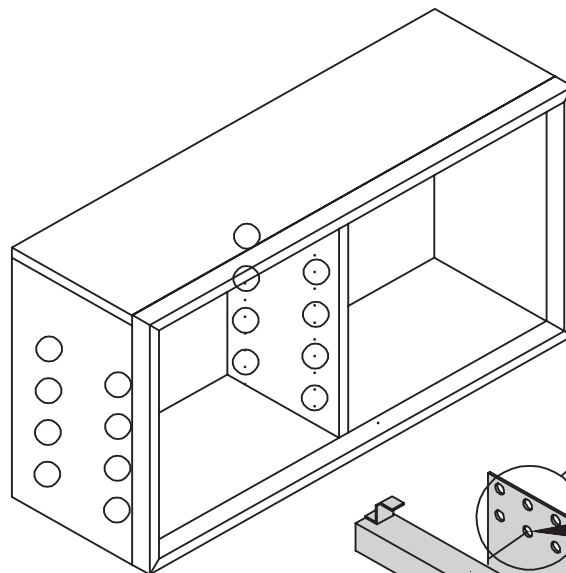
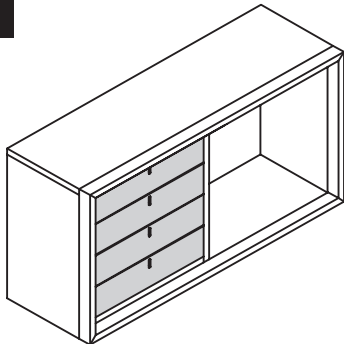

# MONTAGEANLEITUNG Innenschubkästen

Inside drawers  
Tiroirs intérieurs  
Binnenladen

**now!**  
by hülsta

MONTAGE · ASSEMBLY · MONTAGE · MONTAGE

1

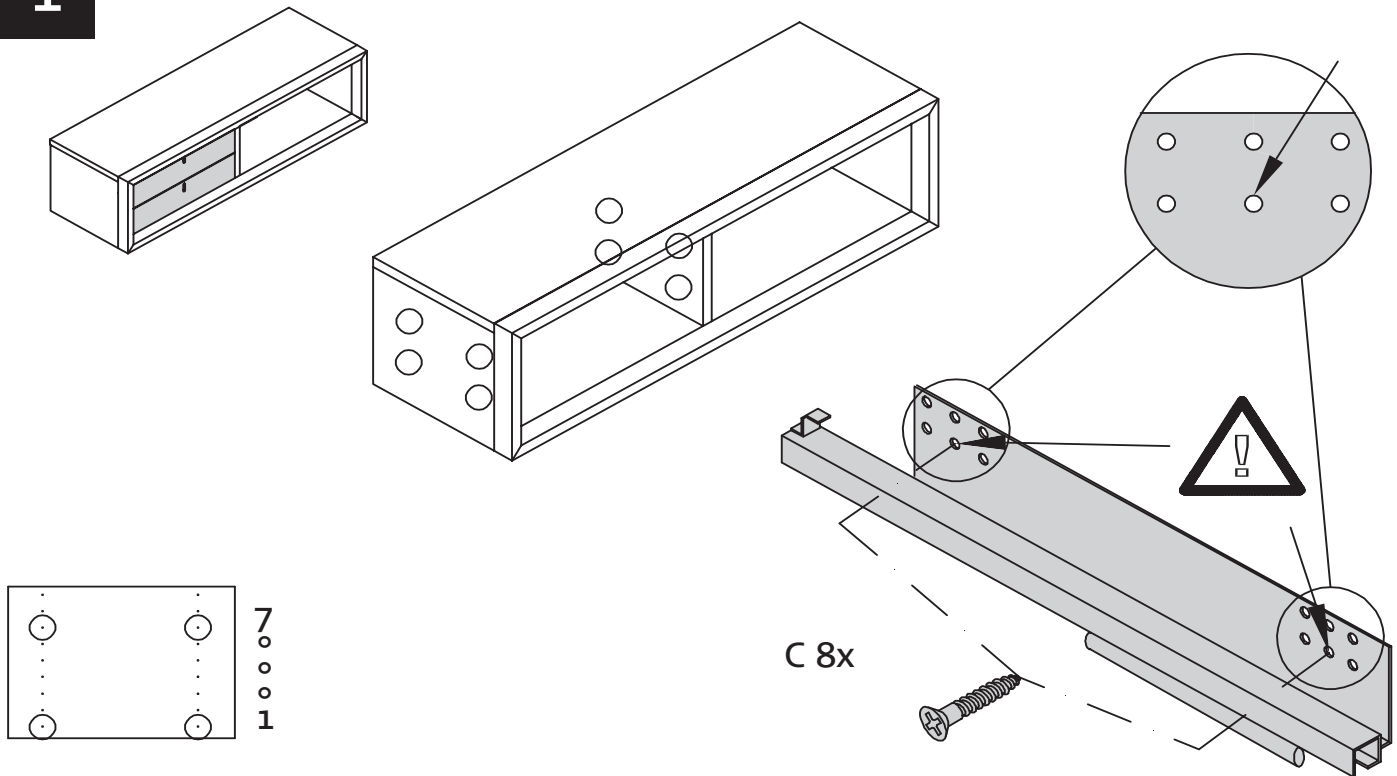

1

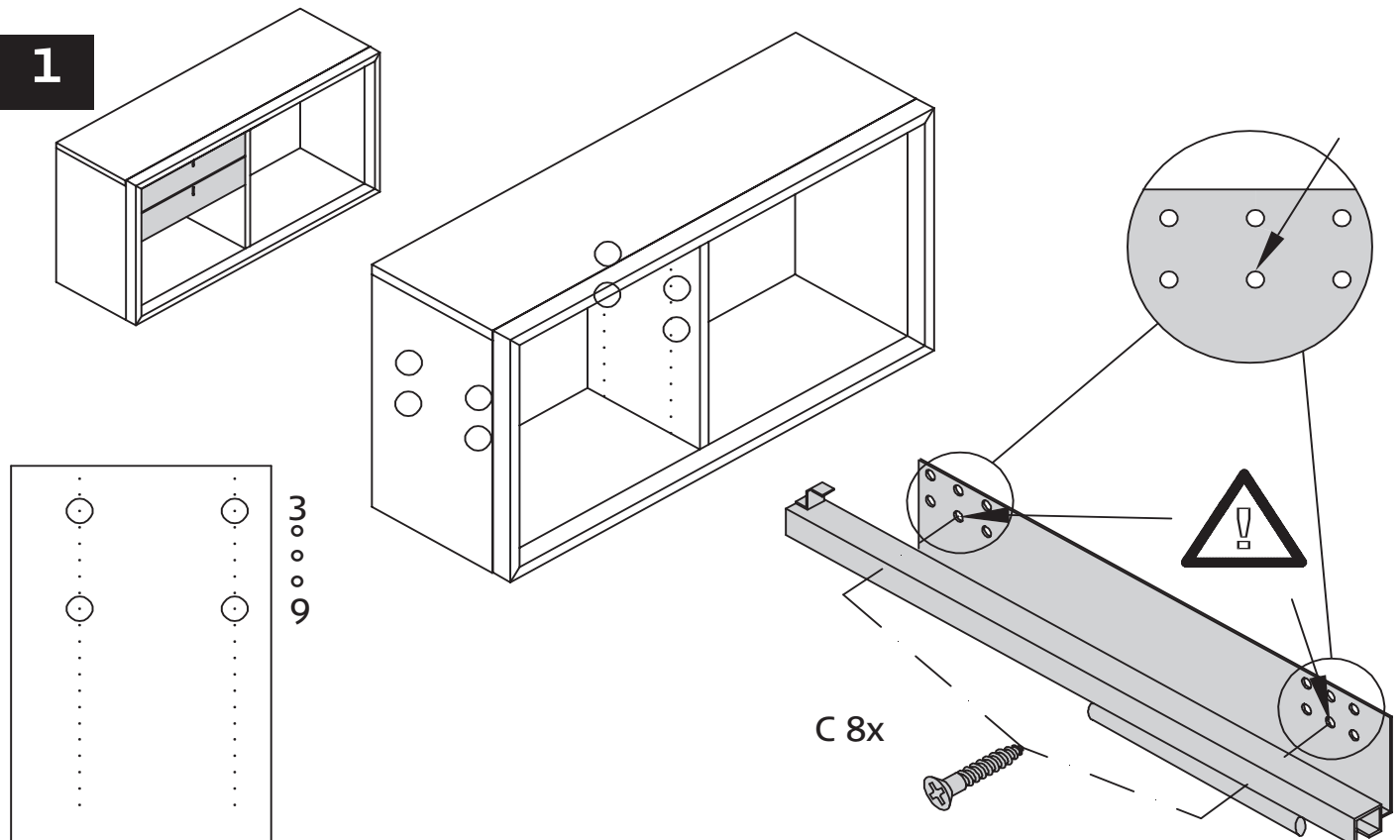

# MONTAGEANLEITUNG Innenschubkästen

Inside drawers  
Tiroirs intérieurs  
Binnenladen

**now!**  
by hülsta

MONTAGE · ASSEMBLY · MONTAGE · MONTAGE

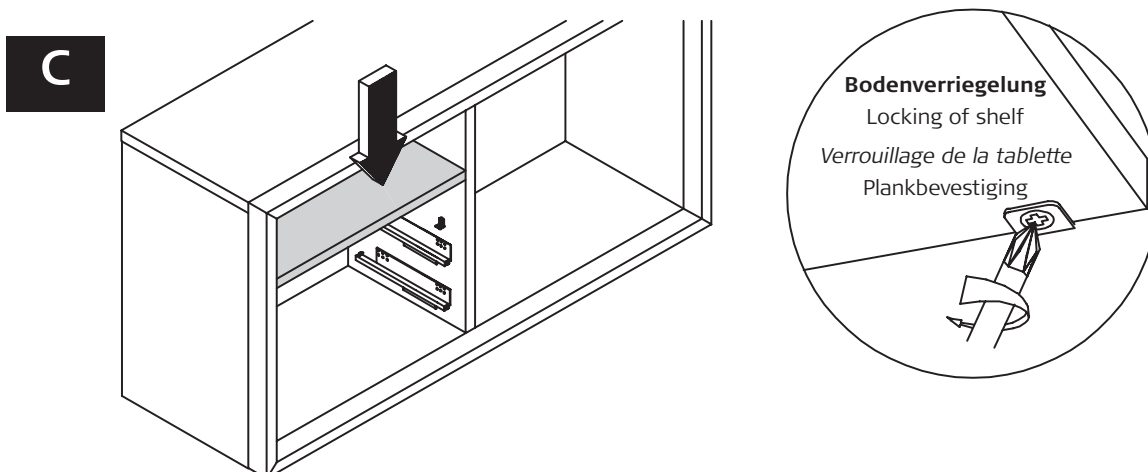
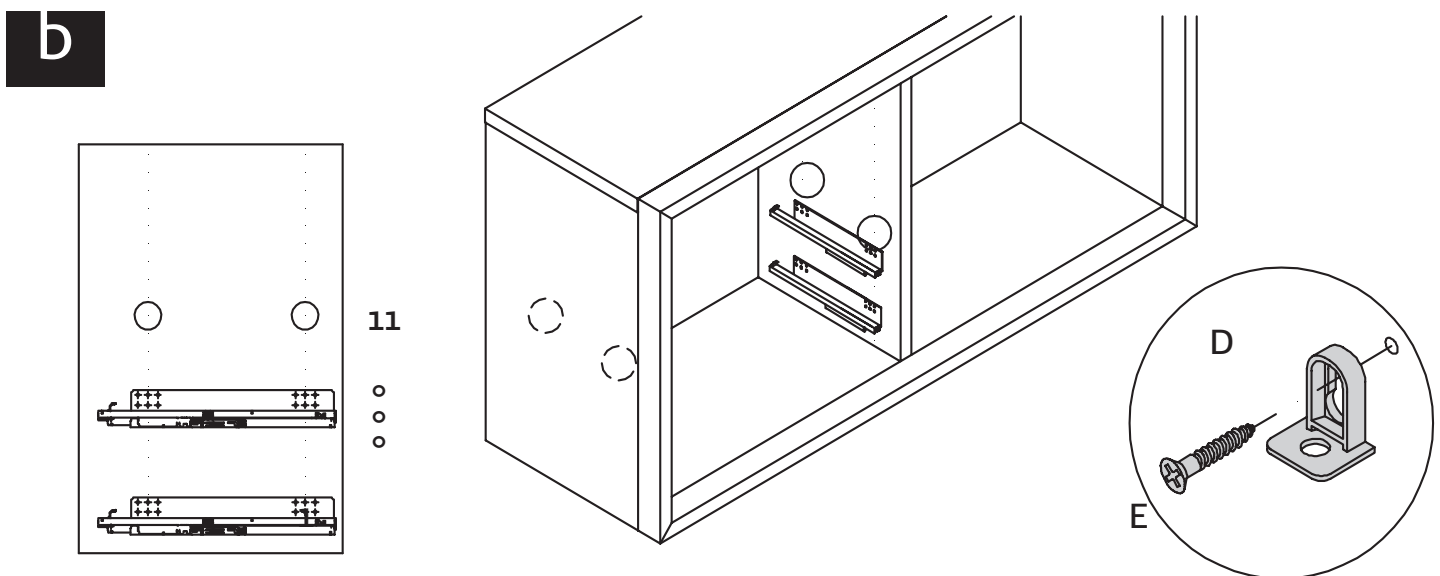
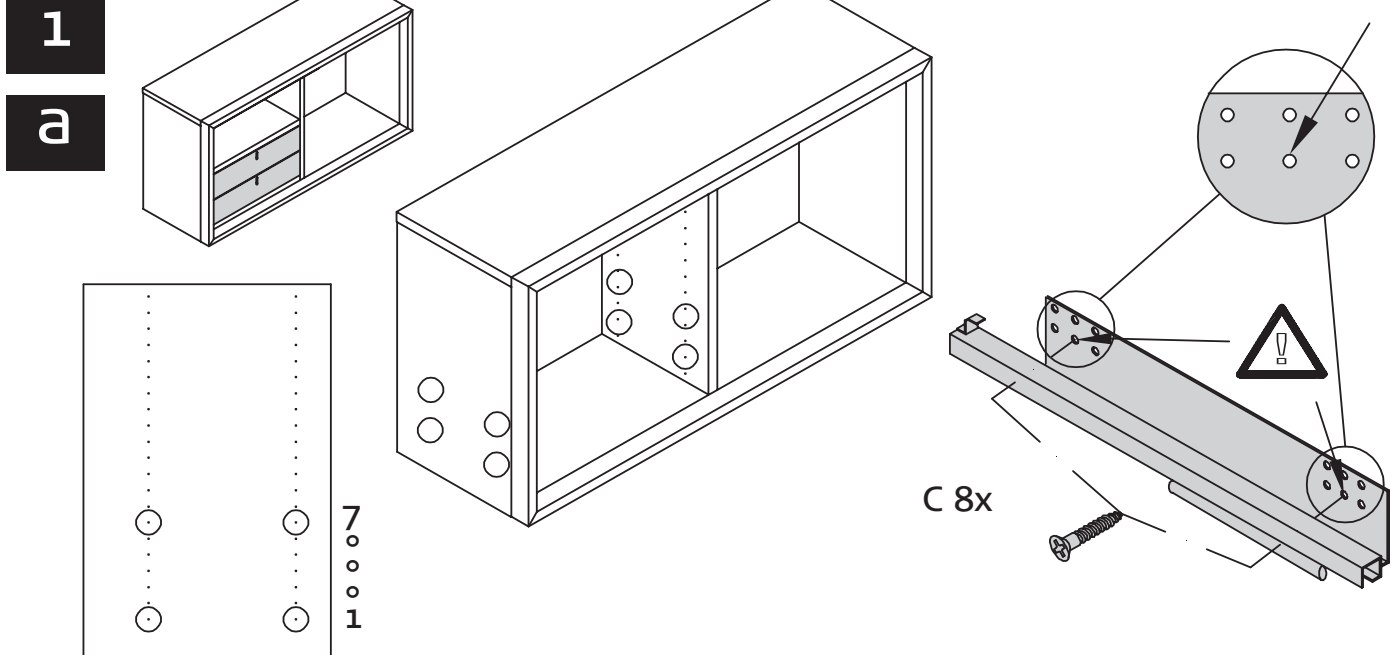

# MONTAGEANLEITUNG Innenschubkästen

Inside drawers  
Tiroirs intérieurs  
Binnenladen

**now!**  
by hülsta

MONTAGE · ASSEMBLY · MONTAGE · MONTAGE

2

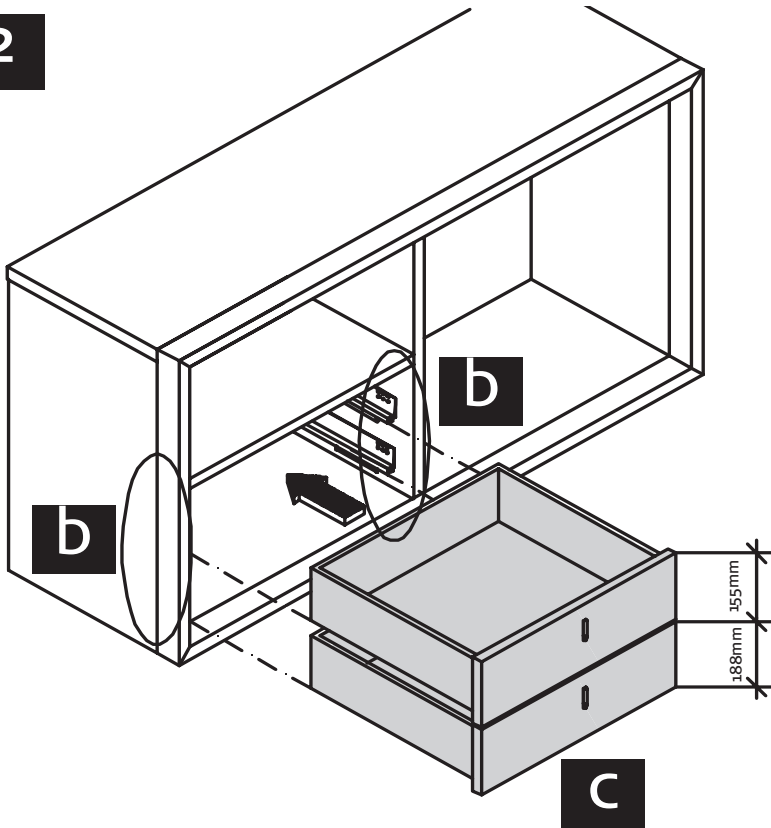

**Bürstendichtung Z muss bei 2 Schubkästen auf 352 mm gekürzt werden.**

Brush seal Z must be reduced to 352 mm for 2 drawers.

*La brosse d'étanchéité Z doit être raccourcie à 352 mm en présence de 2 tiroirs.*

Het borstelprofiel Z moet i.g.v. 2 laden tot 352 mm ingekort worden.

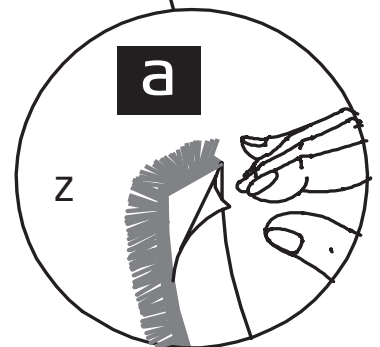
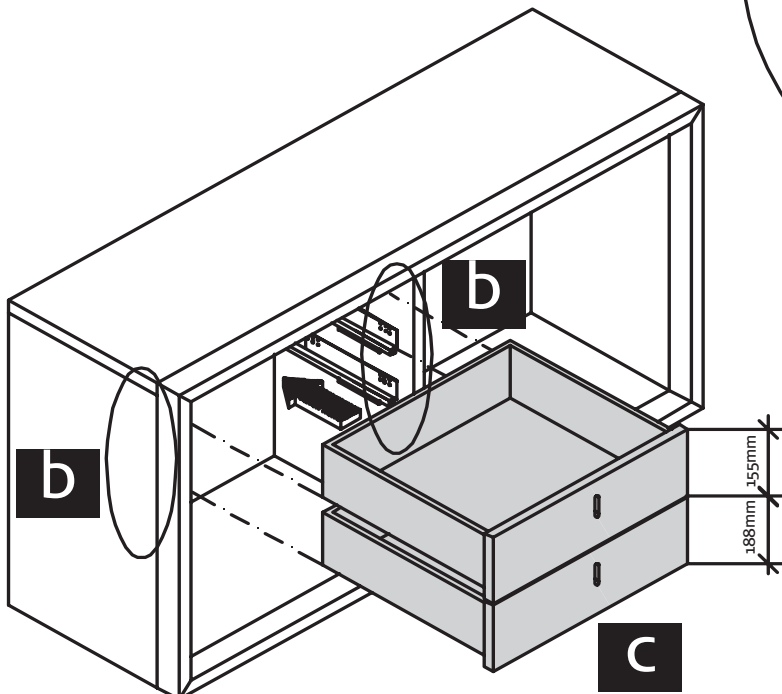
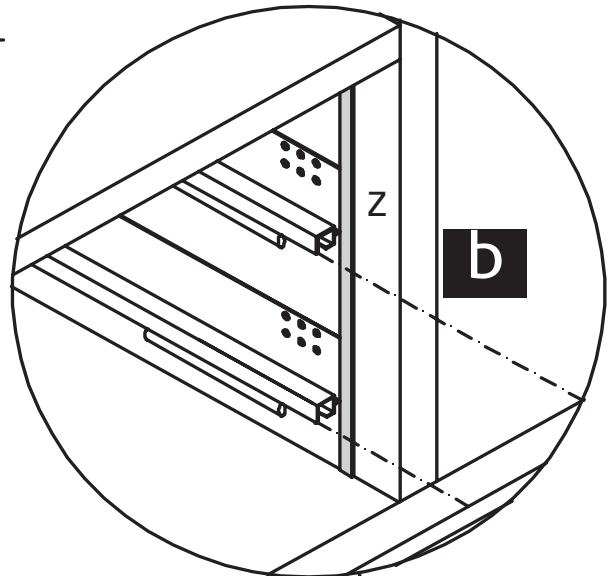

# MONTAGEANLEITUNG Innenschubkästen

Inside drawers  
Tiroirs intérieurs  
Binnenladen

**now!**  
by hülsta

MONTAGE · ASSEMBLY · MONTAGE · MONTAGE

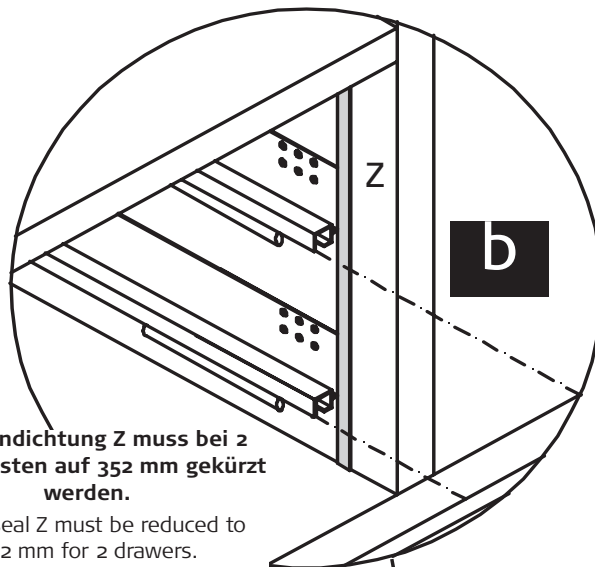
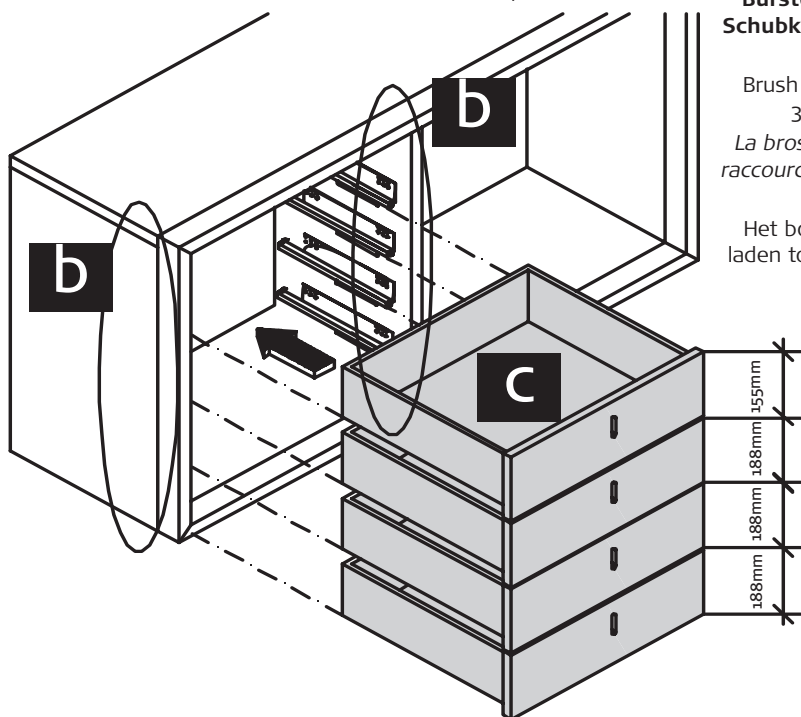
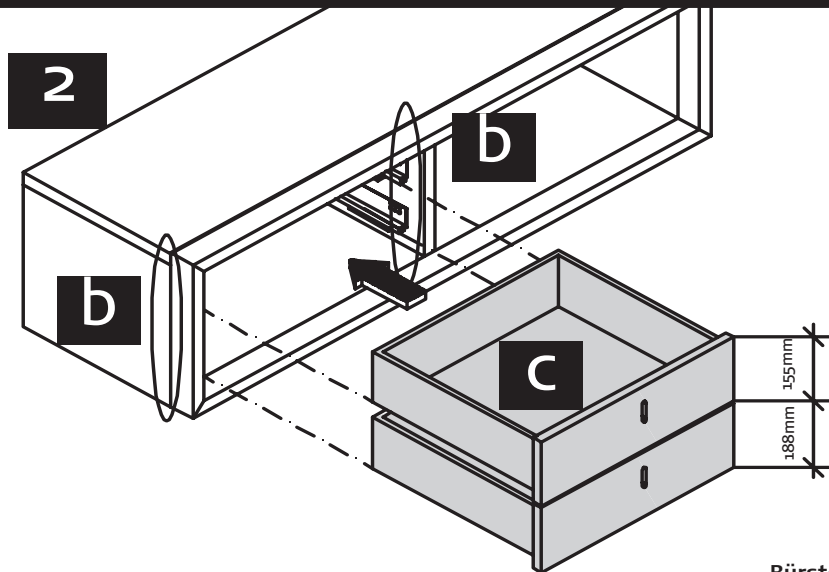

Bürstendichtung Z muss bei 2 Schubkästen auf 352 mm gekürzt werden.

Brush seal Z must be reduced to 352 mm for 2 drawers.

La brosse d'étanchéité Z doit être raccourcie à 352 mm en présence de 2 tiroirs.

Het borstelprofiel Z moet i.g.v. 2 laden tot 352 mm ingekort worden.

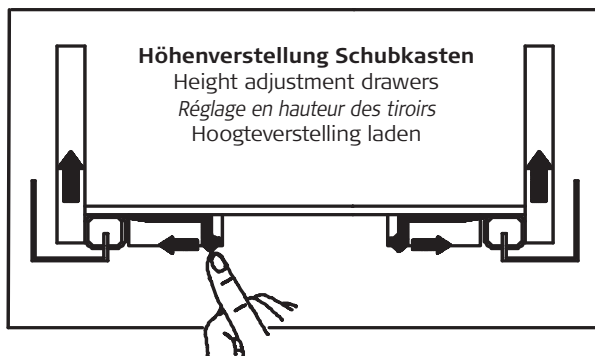
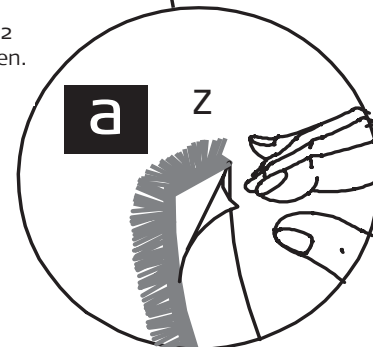

**Höhenverstellung Schubkasten**  
Height adjustment drawers  
Réglage en hauteur des tiroirs  
Hoogteverstelling laden

**Aushängen des Schubkastens**

Detaching the drawer

Dépose du tiroir

Lade demontieren

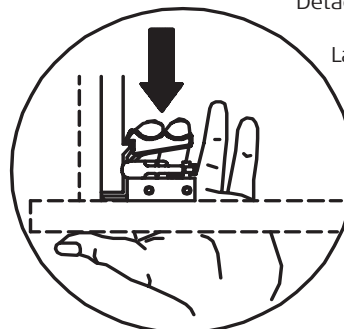

**SERVICE**

Stand: 03.2008

hülsta-werke · Karl-Hüls-Straße 1 · 48703 Stadtlohn  
TEL.+49 2563 86-0 · FAX +49 2563 86-1417  
www.huelsta.com · info@huelsta.com

Mat.Nr.1221337

SEITE 7