



**MONTAGEANLEITUNG
MULTIFUNKTIONSCONTAINER
TYP 7720 / 7722**

MULTI-FUNCTIONAL CONTAINER
CONTAINER MULTI-FONCTIONS
MULTIFUNCTIE-CONTAINER



MONTAGEANLEITUNG · ASSEMBLY INSTRUCTION · NOTICE DE MONTAGE · MONTAGEHANDLEIDING

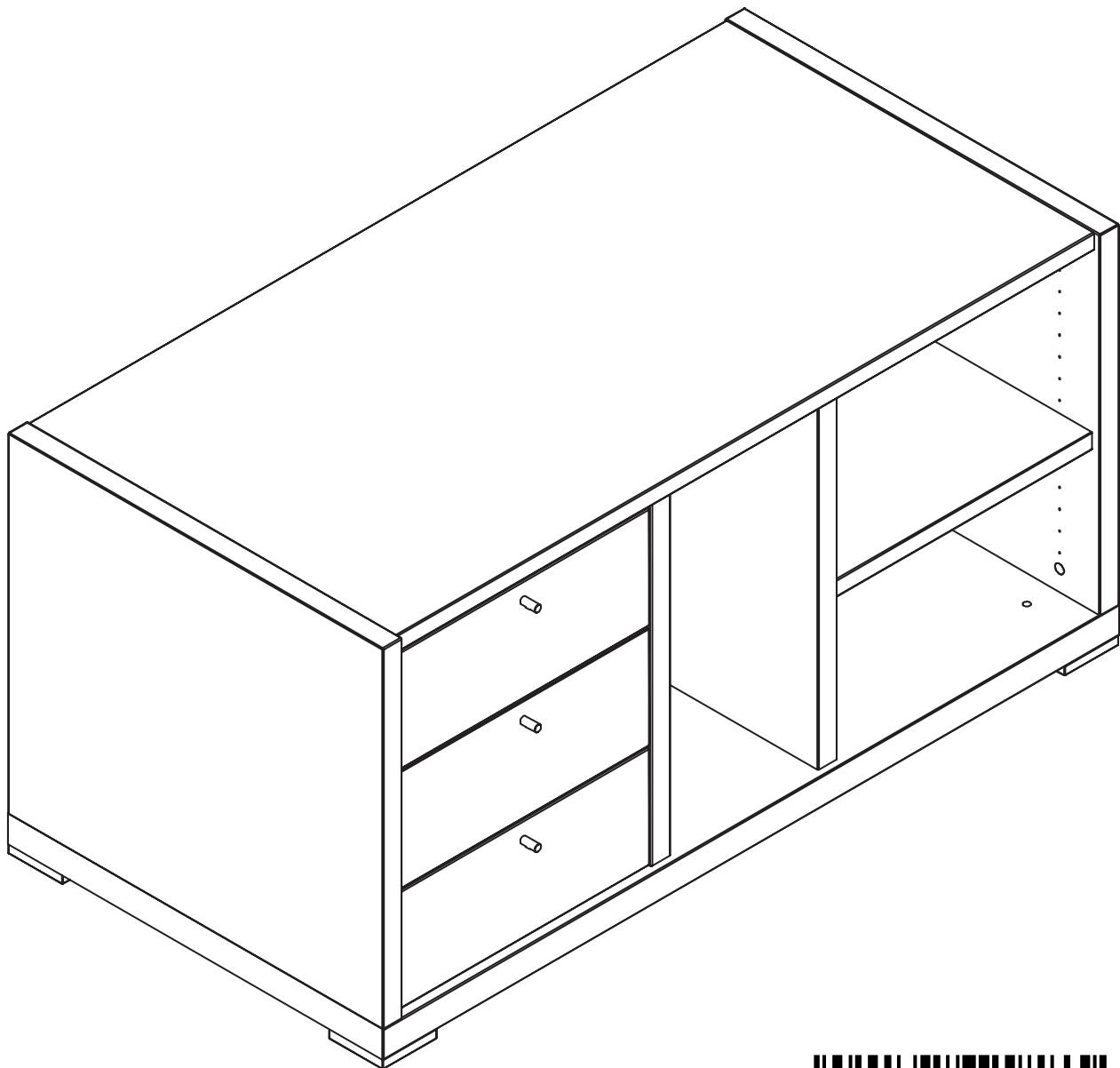

1261276

Lesen Sie zuerst die Anleitung und beginnen Sie dann mit der Montage

Before starting with the fitting, please read carefully the assembly instruction

Avant de commencer avec le montage, nous vous prions de bien lire le notice de montage

Voordat uw met de montage begint, a.u.b. de montagehandleiding lezen

MONTAGEANLEITUNG MULTIFUNKTIONSCONTAINER TYP 7720 / 7722

MULTI-FUNCTIONAL CONTAINER
CONTAINER MULTI-FONCTIONS
MULTIFUNCTIE-CONTAINER



MONTAGEANLEITUNG · ASSEMBLY INSTRUCTION · NOTICE DE MONTAGE · MONTAGEHANDLEIDING

D:

Lieber now! by hülsta – Kunde,
sollten Sie – wider Erwarten - bei der Montage im Bereich der
beigepackten Beschläge Mängel in Form von:

- fehlenden Beschlagteilen
 - falschen Beschlagteilen
 - fehlerhaften Beschlagteilen (z.B. gebrochen, beschädigt o.ä.)
- feststellen, möchten wir Sie im Sinne einer zügigen und fehlerlosen
Abwicklung Ihrer Reklamation um folgende Angaben bitten:

1. Materialnummer des Beschlagkartons
2. Materialnummer und Stückzahl des Beschlagteils
3. Reklamationsgrund (z.B. fehlt, falsch, defekt, gebrochen...)
4. Packdatum (sofern vorhanden) der Beschlagkartonage
5. Prüfnummer (sofern vorhanden) auf dem Beschlagkarton

Diese Angaben können sie wahlweise per

E-mail: hotline@now.de

oder über die

now! by hülsta Servicehotline: 02563/ 86 - 1500

an uns weitergeben.

Bitte beachten Sie, dass einzelne Beschlagteile für Ihr Möbel nach erfolgter
Montage übrig sein können. Bei Beachtung aller Montageschritte kann dies
an der Mehrfachverwendung der Beschlagkartonagen für verschiedene
now-Typen liegen. Nicht jede Type benötigt alle Beschlagteile!

Mit freundlichen Grüßen

Ihr now! by hülsta - Team

GB:

Dear now! by hülsta customer,

If – contrary to expectations - there should be any discrepancies in the
accompanying fittings needed for assembly, such as:

- missing fittings
- incorrect fittings
- faulty fittings (e.g. broken, damaged, etc.)

we would like you to provide us with the following information so that your
complaint can be dealt with as quickly and successfully as possible:

1. Material number of fitting bracket packet
2. Material number and quantity of fitting brackets
3. Reason for complaint (e.g. part missing, incorrect, defective, broken...)
4. Date of packaging (if known) of fitting bracket packet
5. Check number (if known) on the fitting bracket packet

You can send us this data either by

e-mail: hotline@now.de

or by calling the

now! by hülsta service hotline: +49 (0) 2563 / 86 - 1500

Please note: as a result of using identical fitting bags for different now types, there
might be some fittings remaining after installing your furniture, even when the fitting
instructions have been followed step by step. Not every type requires all of the
fittings.

With kind regards

Your now! by hülsta team

1. Materialnummer Beschlagkarton

1. Material number of fitting bracket packet

1. Référence du carton des ferrures

1. Materialnummer beslagdelendoos

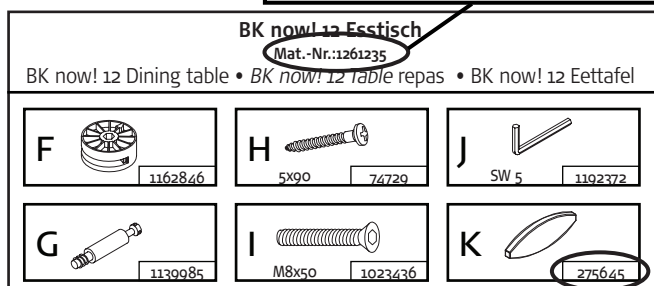

2. Materialnummer Beschlagteil

2. Material number of fitting bracket

2. Référence de la pièce de la ferrure

2. Materiaalnummer beslagdeel

F:

Cher client now! by hülsta,

dans le cas où vous constateriez lors du montage, contrairement à nos intentions,
des anomalies dans le secteur des ferrures livrées se présentant sous les formes
suivantes:

- manque de certaines éléments des ferrures
- ferrures non adaptées
- éléments des ferrures défectueux (par exemple: cassées, abîmées ou similaires),
nous vous demandons de bien vouloir nous communiquer lors de votre réclamation
les données suivantes afin de permettre une réaction rapide et précise:

1. Référence du carton des ferrures
2. Référence et quantité de la pièce de la ferrure
3. Raison de la réclamation (par exemple: manque,
inadaptation, malfaçon, cassé...)
4. Date d'emballage (si disponible) du carton des ferrures
5. Numéro de contrôle (si disponible) sur le carton de ferrures

Il vous est possible de nous communiquer ces données par

e-mail: hotline@now.de

ou en appelant notre

service hotline now! by hülsta: +49 (0) 2563 / 86 - 1500

Veuillez noter qu'il est possible que certains éléments des ferrures destinées à votre
meuble soient en surnombre après un montage bien effectué. Si vous avez respecté
toutes les étapes du montage, cela peut venir du fait que le carton des ferrures est
utilisé pour plusieurs articles now. Tous les éléments des ferrures ne sont pas obliga-
toirement nécessaires pour tous les articles!

Avec nos sincères salutations

L'équipe now! by hülsta

NL:

Geachte now! by hülsta-klant,

Indien u - tegen alle verwachtingen in - tijdens de montage m.b.t. de bijgepakte
beslagdelen klachten hebt, zoals:

- het ontbreken van bepaalde beslagdelen
- het onvoldoende ontvangen hebben van bepaalde beslagdelen
- of het hebben ontvangen van defecte beslagdelen
(bijv. gebroken of ernstig beschadigd),

dan verzoeken wij u - om uw reclamatie snel en correct te kunnen afwikkelen -
ons de volgende gegevens te verstrekken:

1. het materiaalnummer van de doos met beslagdelen
2. het materiaalnummer en het aantal stuks van de betr. beslagdelen
3. de reden van de reclamatie (bijv. ontbrak, verkeerd, defect, gebroken ...)
4. de inpakdatum op de doos met beslagdelen (indien voorhanden)
5. het controlenummer op de doos met beslagdelen (indien voorhanden)

Deze gegevens kunt u of per

e-mail: hotline@now.de

sturen, of per

now! by hülsta servicehotline: +49 (0) 2563 / 86 - 1500

telefonisch doorgeven.

Let u er s.v.p. op dat er na het monteren van uw meubels beslagdelen over kun-
nen zijn. Als u alle montageschappen heeft uitgevoerd, kan dit aan het gebruik van
standaard beslagdelenpakketten voor verschillende now-types liggen. Niet voor elk
type zijn alle beslagdelen nodig!

Met vriendelijke groeten,

uw now! by hülsta-team

Angaben auf der Beschlagkartonage:

Data on fitting bracket packet:

Données sur le carton des ferrures:

Gegevens op de beslagdelendoos:

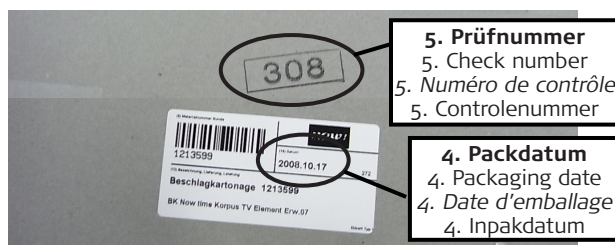

5. Prüfnummer

5. Check number

5. Numéro de contrôle

5. Controlenummer

4. Packdatum

4. Packaging date

4. Date d'emballage

4. Inpakdatum

MONTAGEANLEITUNG MULTIFUNKTIONSCONTAINER TYP 7720 / 7722

MULTI-FUNCTIONAL CONTAINER
CONTAINER MULTI-FONCTIONS
MULTIFUNCTIE-CONTAINER

now! no.12

by hülsta

GESAMTÜBERSICHT · SUMMARY · VUE GENERALE · TOTAALOVERZICHT









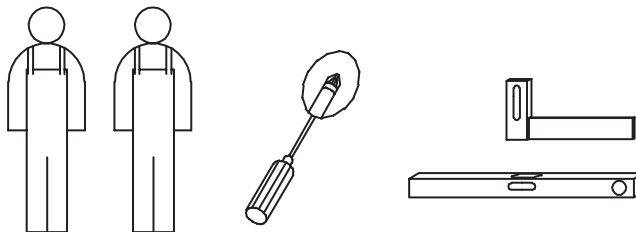

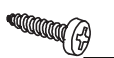

Für die Montage wird benötigt:

Necessary for assembly:

Pour le montage il faut:

Benodigdheden voor de montage:

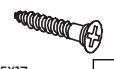
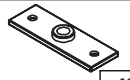
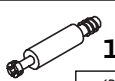

BK now! 12 Multifunktions-Container			
Mat.-Nr.:1261240			
BK now! 12 multi-functional container • BK now! 12 container multi-fonctions • BK now! 12 multifunctie-container			
I  3X 1116417	M  4X 1258580	Q  20X 4x17 275764	U  18X Ø 15x29 316997
J  3X 4x27 348984	N  12X 3.5x17 440215	R  8X 275481 Natur-Eiche • Natural oak • Chêne nature • Natuurlijk eiken 81702 Eiche anthrazit • Oak anthracite • Chêne anthracite • Eiken antraciet	V  22X 1265852 Natur-Eiche • Natural oak • Chêne nature • Natuurlijk eiken 1120625 Eiche anthrazit • Oak anthracite • Chêne anthracite • Eiken antraciet
K  10X TAB V26 279361	O  6X 1192514	S  1X 153301	W  4X 682789
L  10X 5x17 593253	P  2X 1049104	T  18X 433230	X  4X 641391

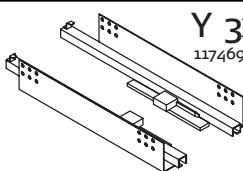
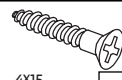
3x BK now! 12 SK Schienen MFC	
Mat.-Nr.:1266440	
BK now! 12 drawer rails MFC • BK now! 12 tiroir rails MFC • BK now! 12 ladelopers voor MFC	
Y  3X 1174692	Z  12X 4x15 936774

Verehrter Kunde, hier haben Sie die Möglichkeit die mitgelieferten Schrauben nachzumessen!

Dear customer, here you find a possibility to measure the delivered screws!

Cher client, ici vous avez la possibilité de mesurer les vis livrées!

Beste klant, hier heeft uw de mogelijkheid de schroeven te meten!



**MONTAGEANLEITUNG
MULTIFUNKTIONSCONTAINER
TYP 7720 / 7722**

MULTI-FUNCTIONAL CONTAINER
CONTAINER MULTI-FONCTIONS
MULTIFUNCTIE-CONTAINER

now! no.12
by hülsta

MONTAGE · ASSEMBLY · MONTAGE · MONTAGE

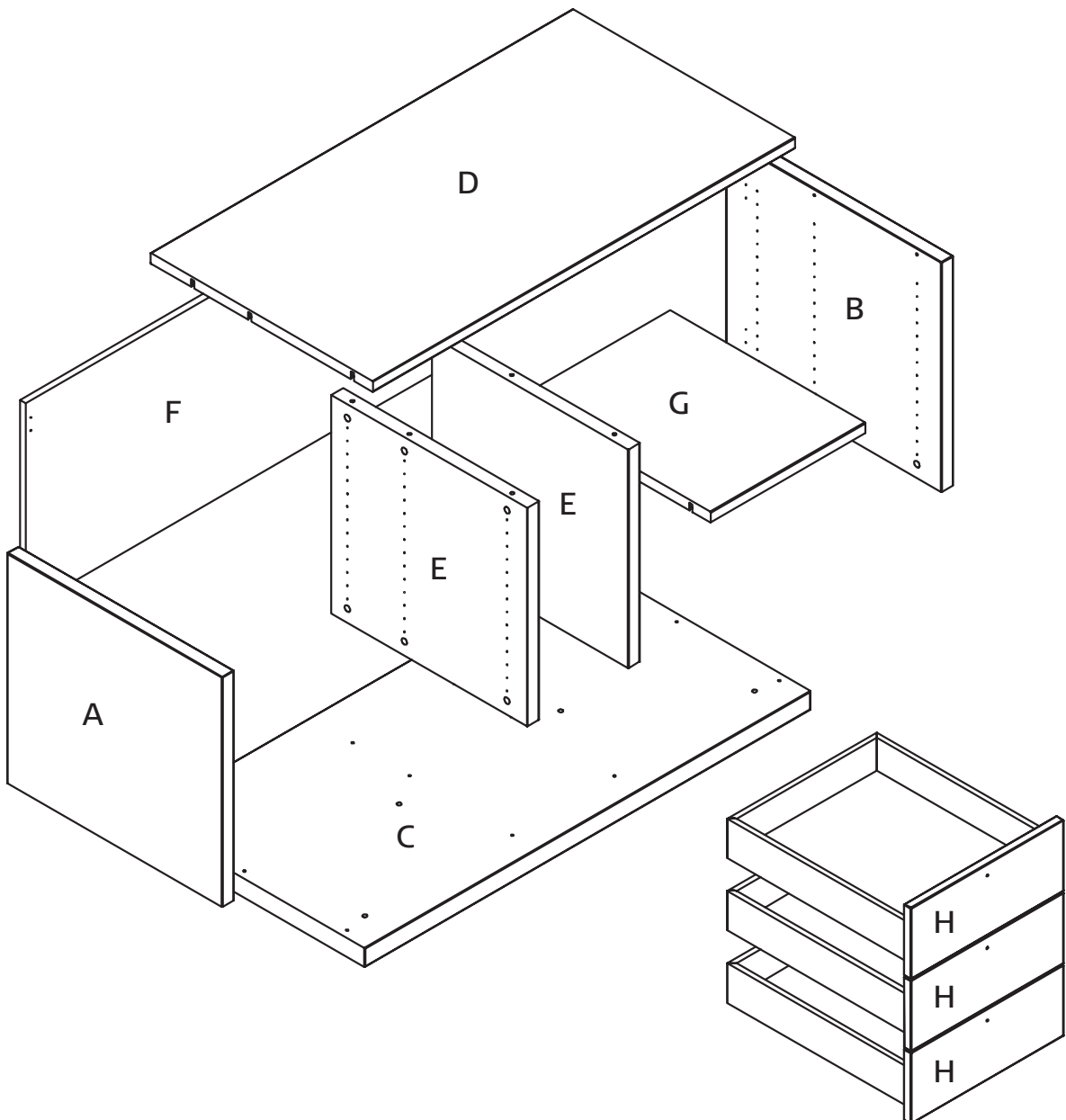
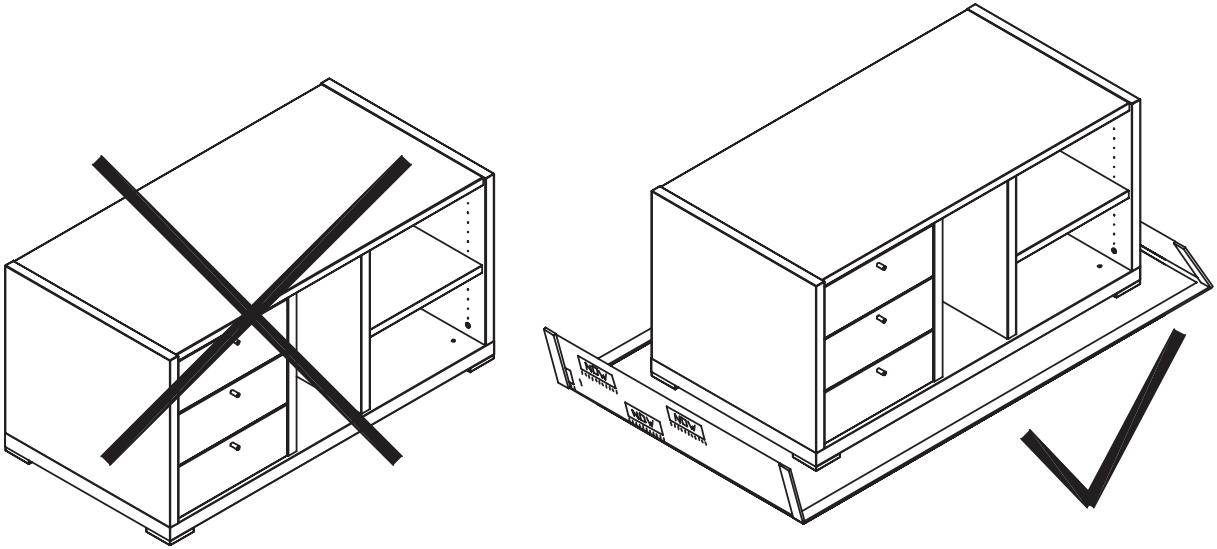

MONTAGEANLEITUNG MULTIFUNKTIONSCONTAINER TYP 7720 / 7722

MULTI-FUNCTIONAL CONTAINER
CONTAINER MULTI-FONCTIONS
MULTIFUNCTIE-CONTAINER

now! no.12
by hülsta

MONTAGE · ASSEMBLY · MONTAGE · MONTAGE

1

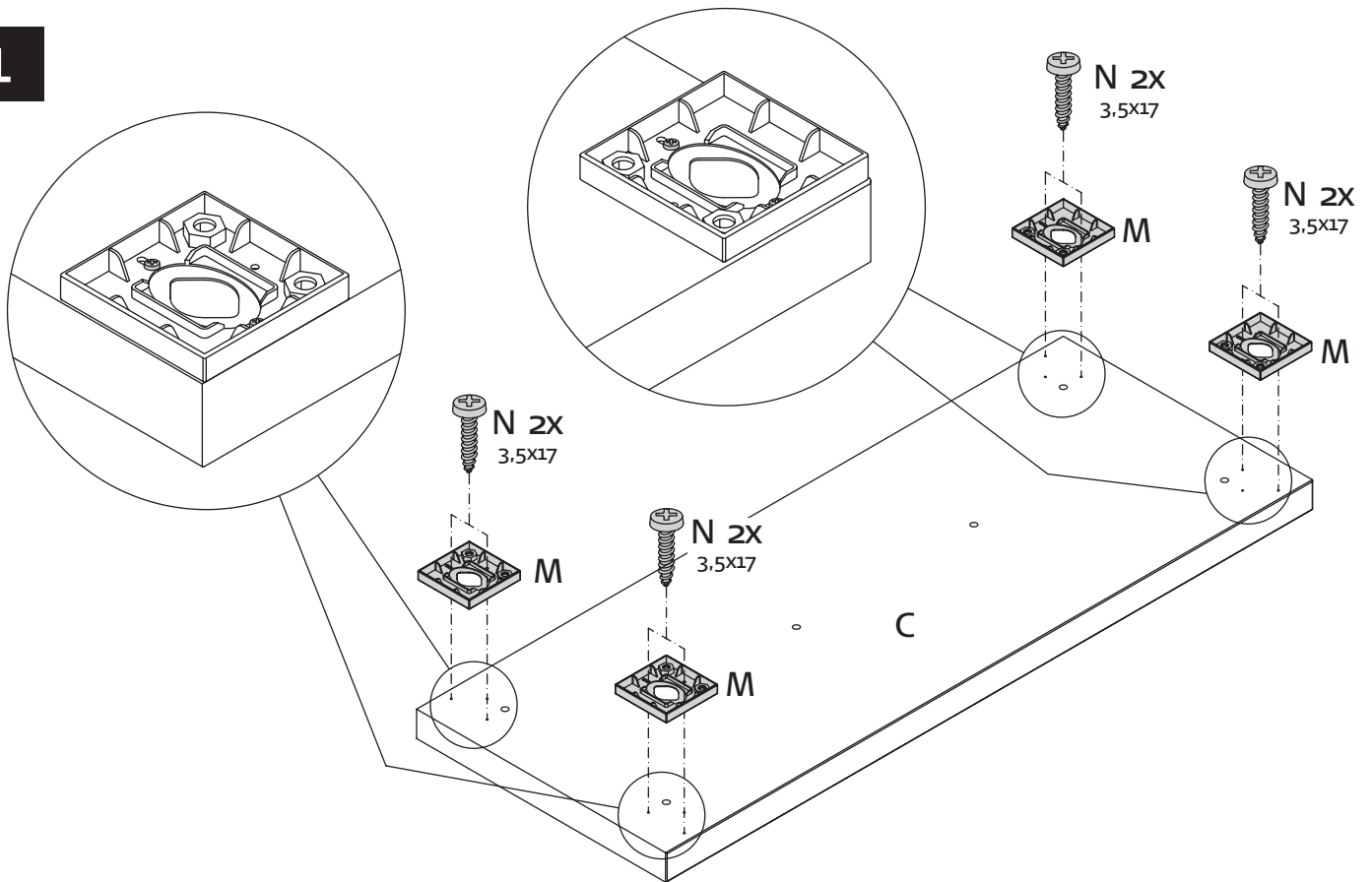

2

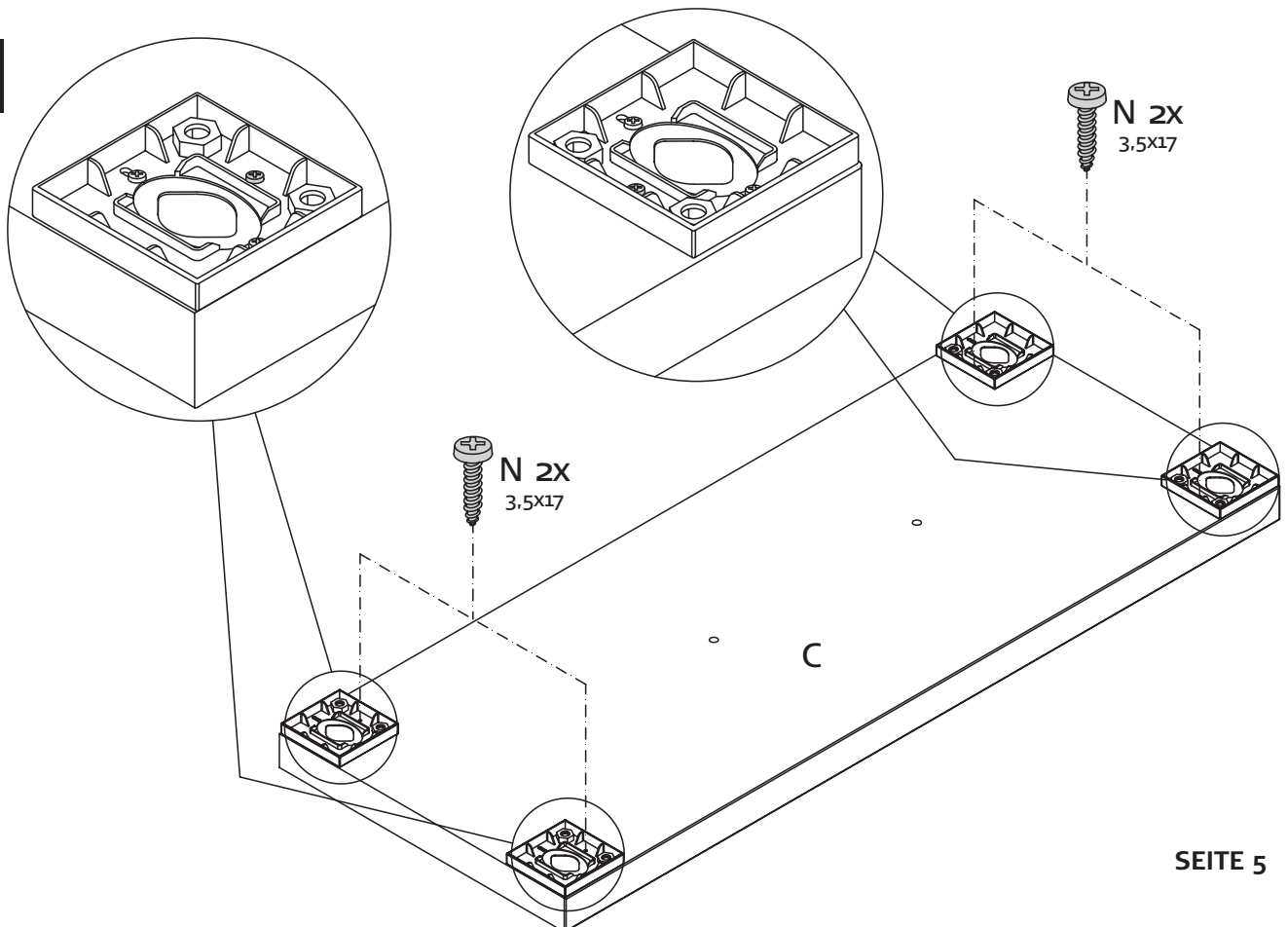

**MONTAGEANLEITUNG
MULTIFUNKTIONSCONTAINER
TYP 7720 / 7722**

MULTI-FUNCTIONAL CONTAINER
CONTAINER MULTI-FONCTIONS
MULTIFUNCTIE-CONTAINER

now! no.12
by hülsta

MONTAGE · ASSEMBLY · MONTAGE · MONTAGE

3

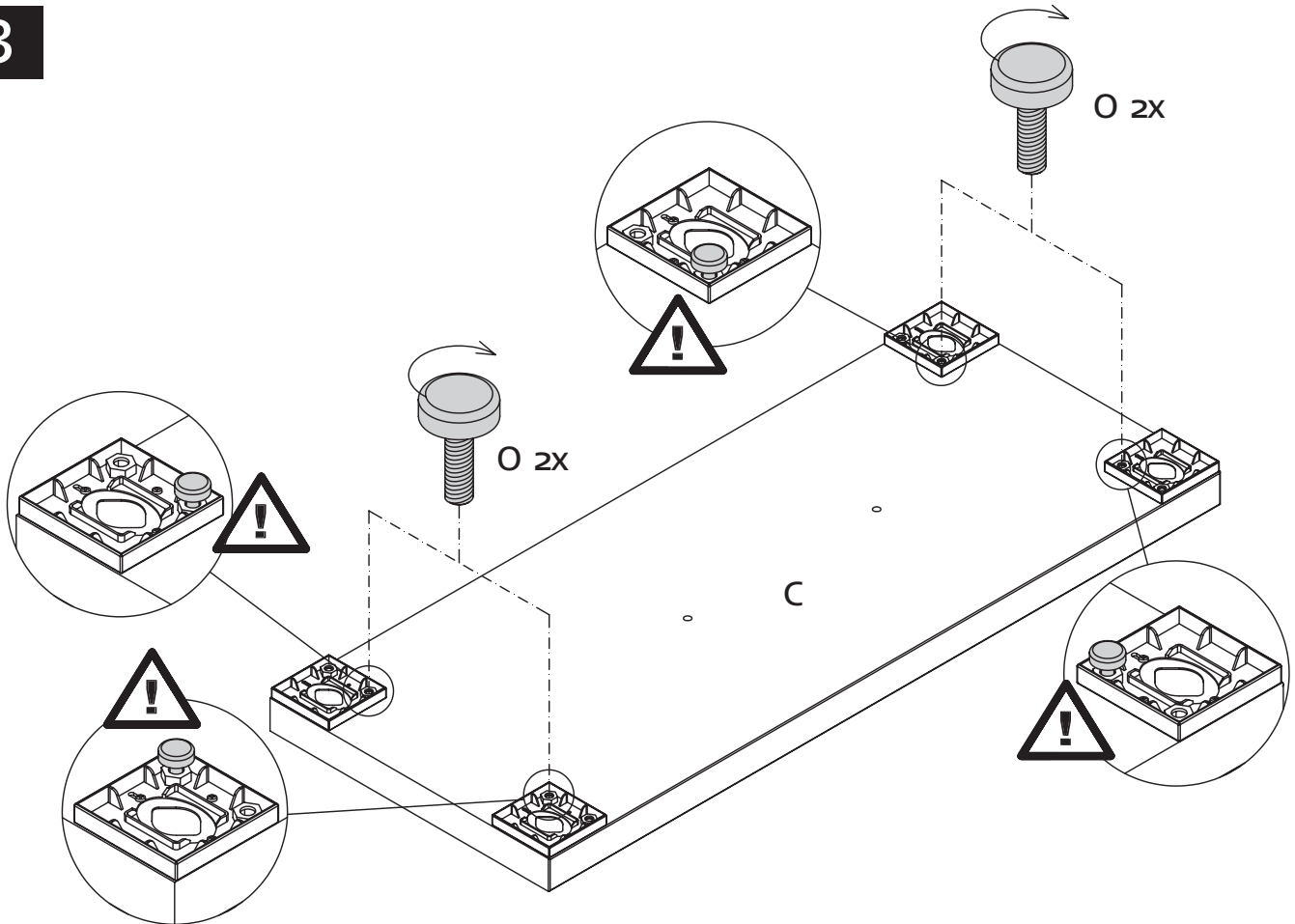

4

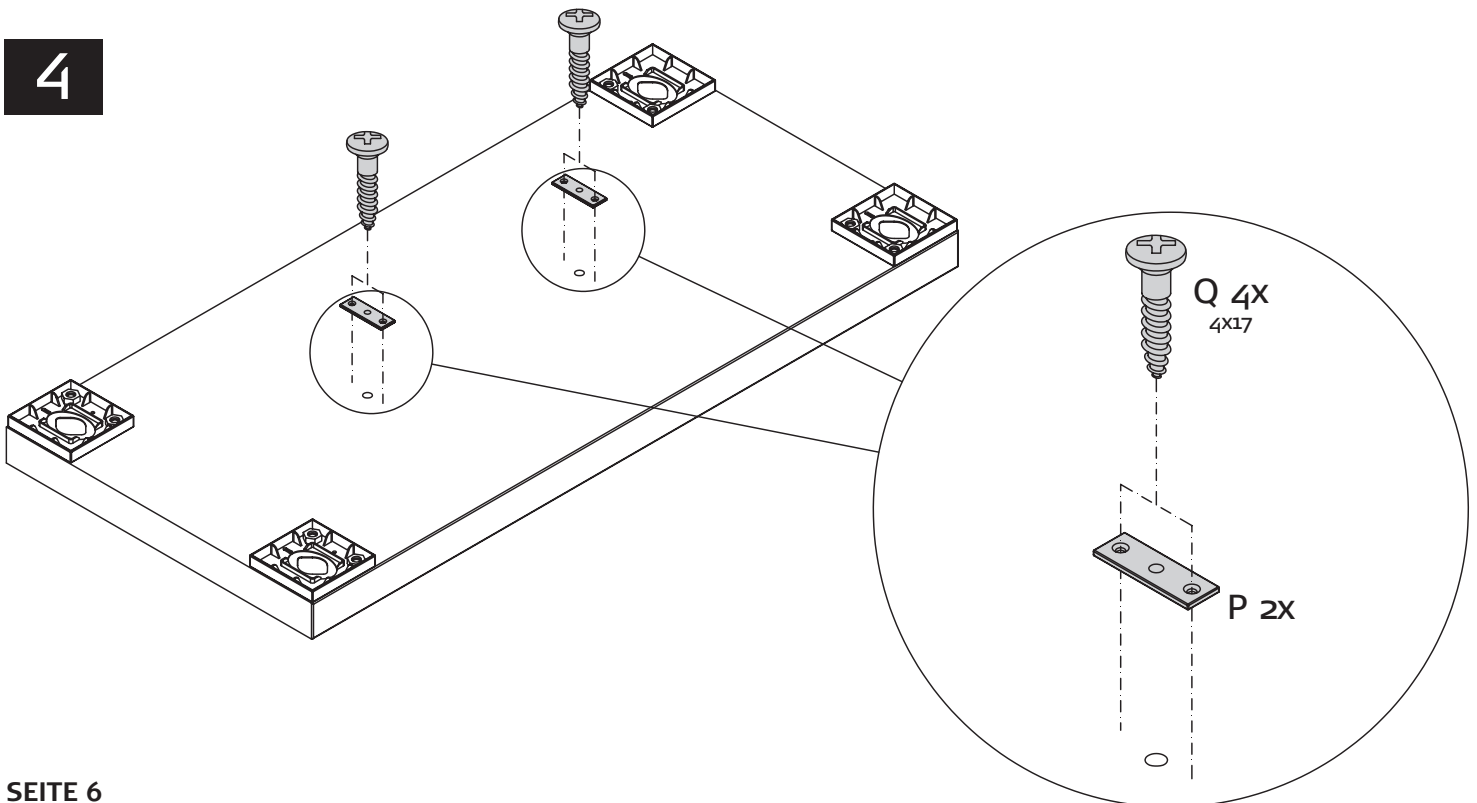

MONTAGEANLEITUNG MULTIFUNKTIONSCONTAINER TYP 7720 / 7722

MULTI-FUNCTIONAL CONTAINER
CONTAINER MULTI-FONCTIONS
MULTIFUNCTIE-CONTAINER



MONTAGE · ASSEMBLY · MONTAGE · MONTAGE

5

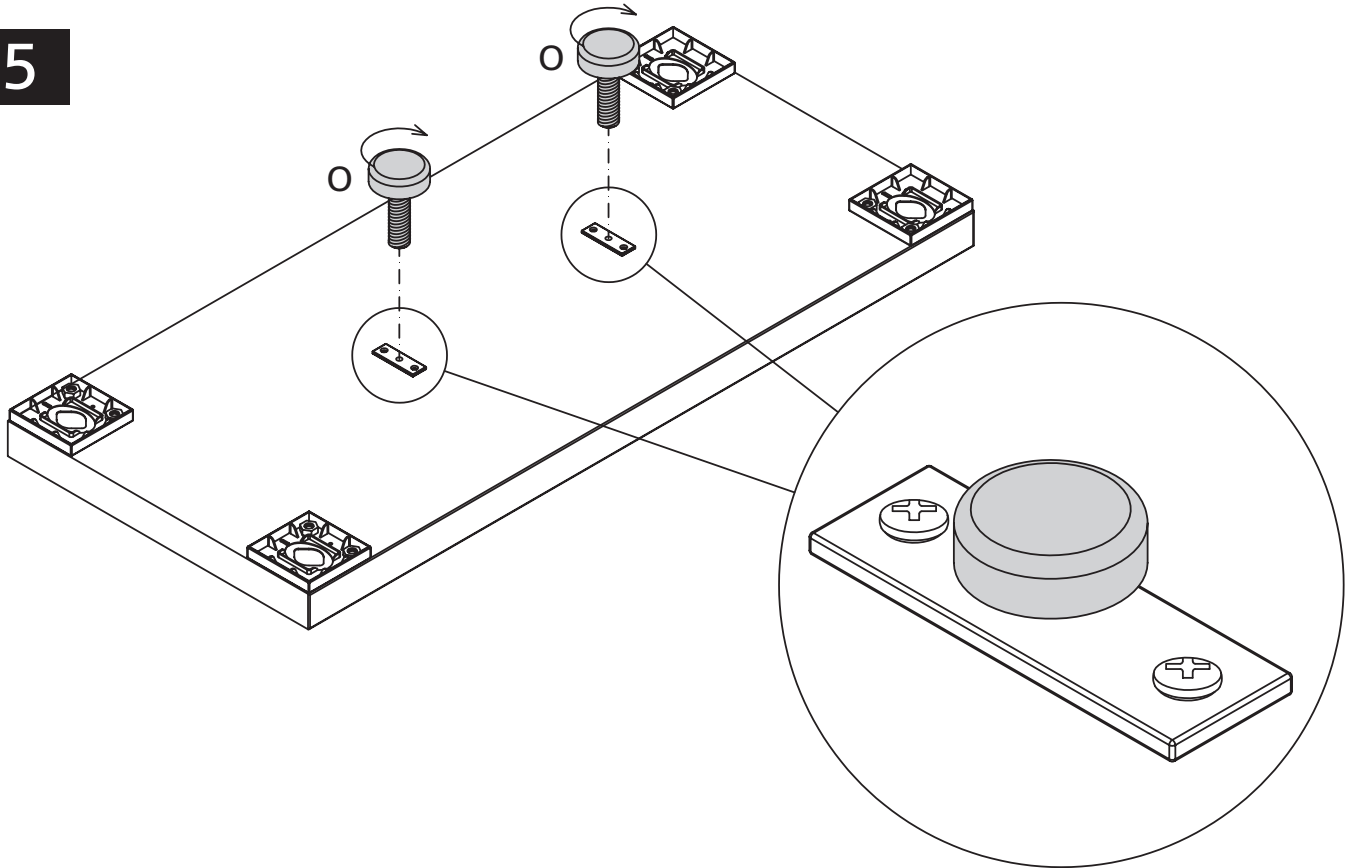

6

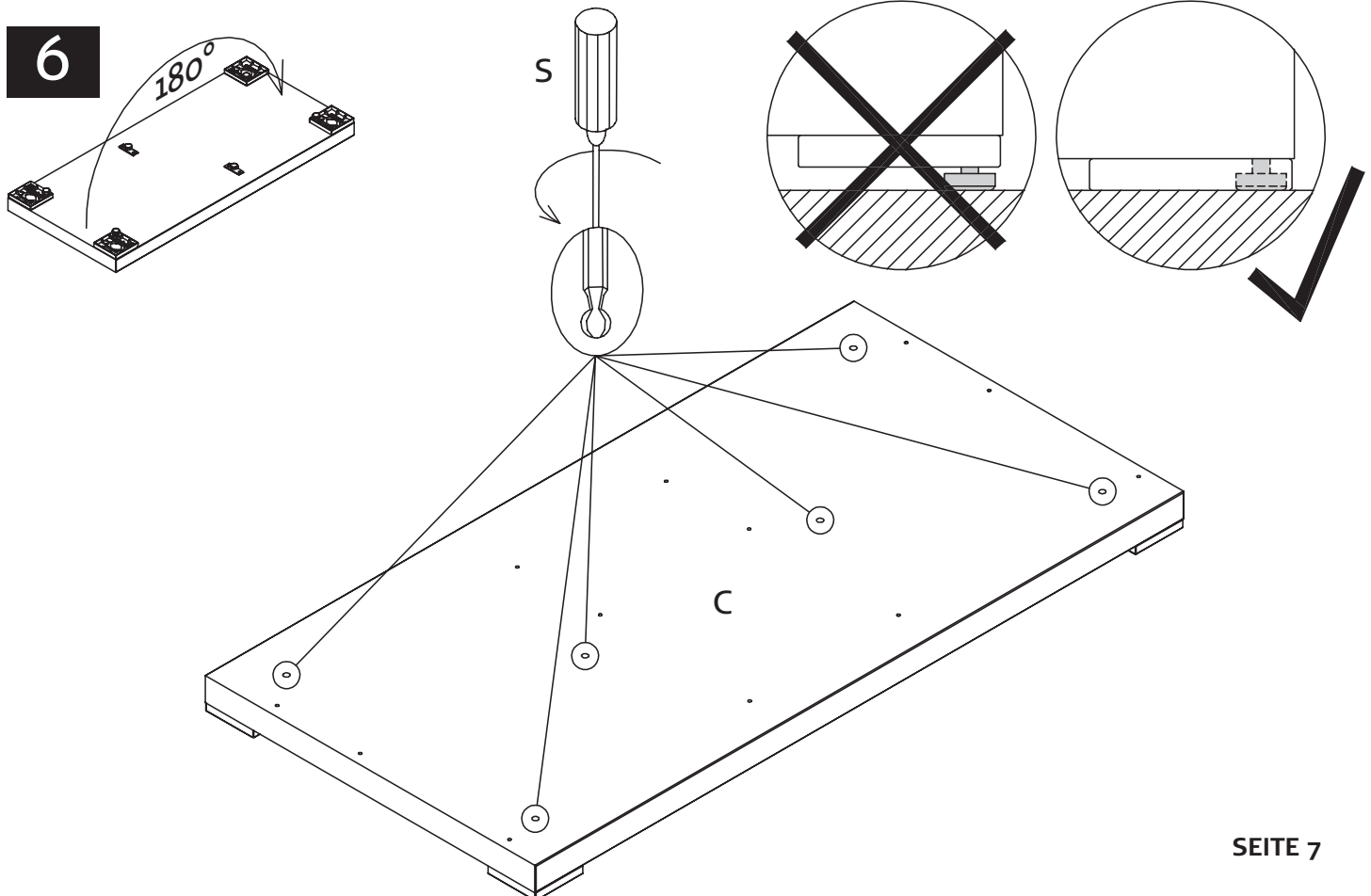

**MONTAGEANLEITUNG
MULTIFUNKTIONSCONTAINER
TYP 7720 / 7722**

MULTI-FUNCTIONAL CONTAINER
CONTAINER MULTI-FONCTIONS
MULTIFUNCTIE-CONTAINER

now! no.12
by hülsta

MONTAGE · ASSEMBLY · MONTAGE · MONTAGE

7

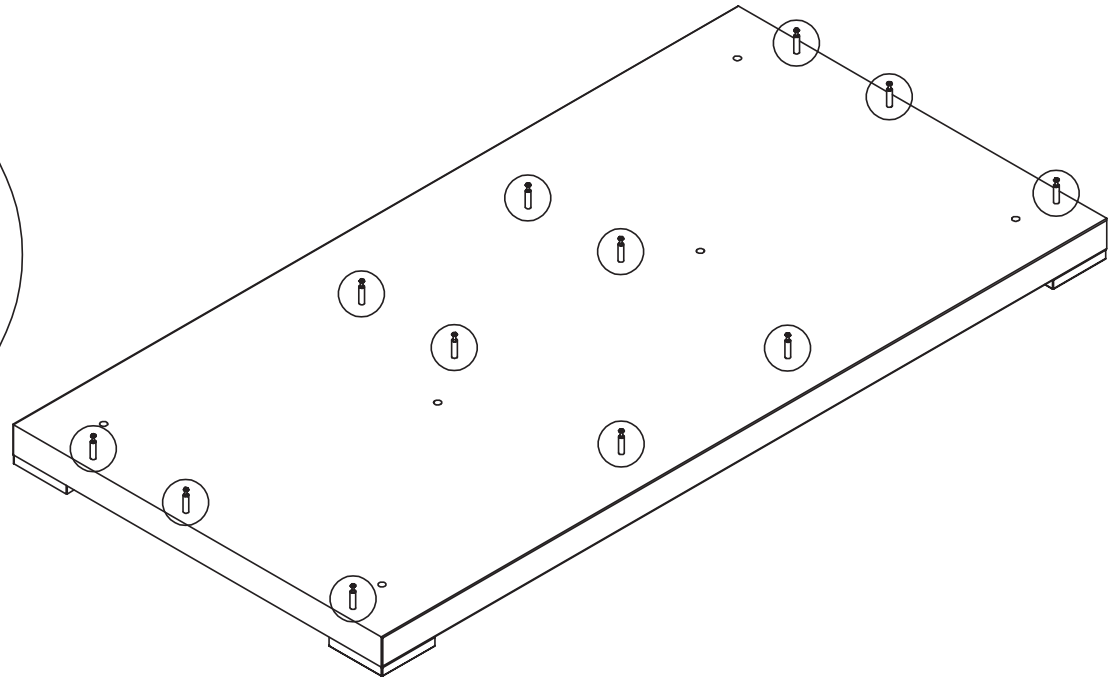
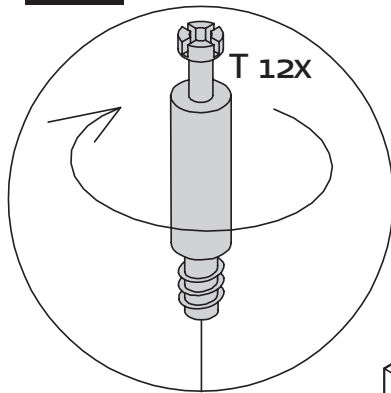

8

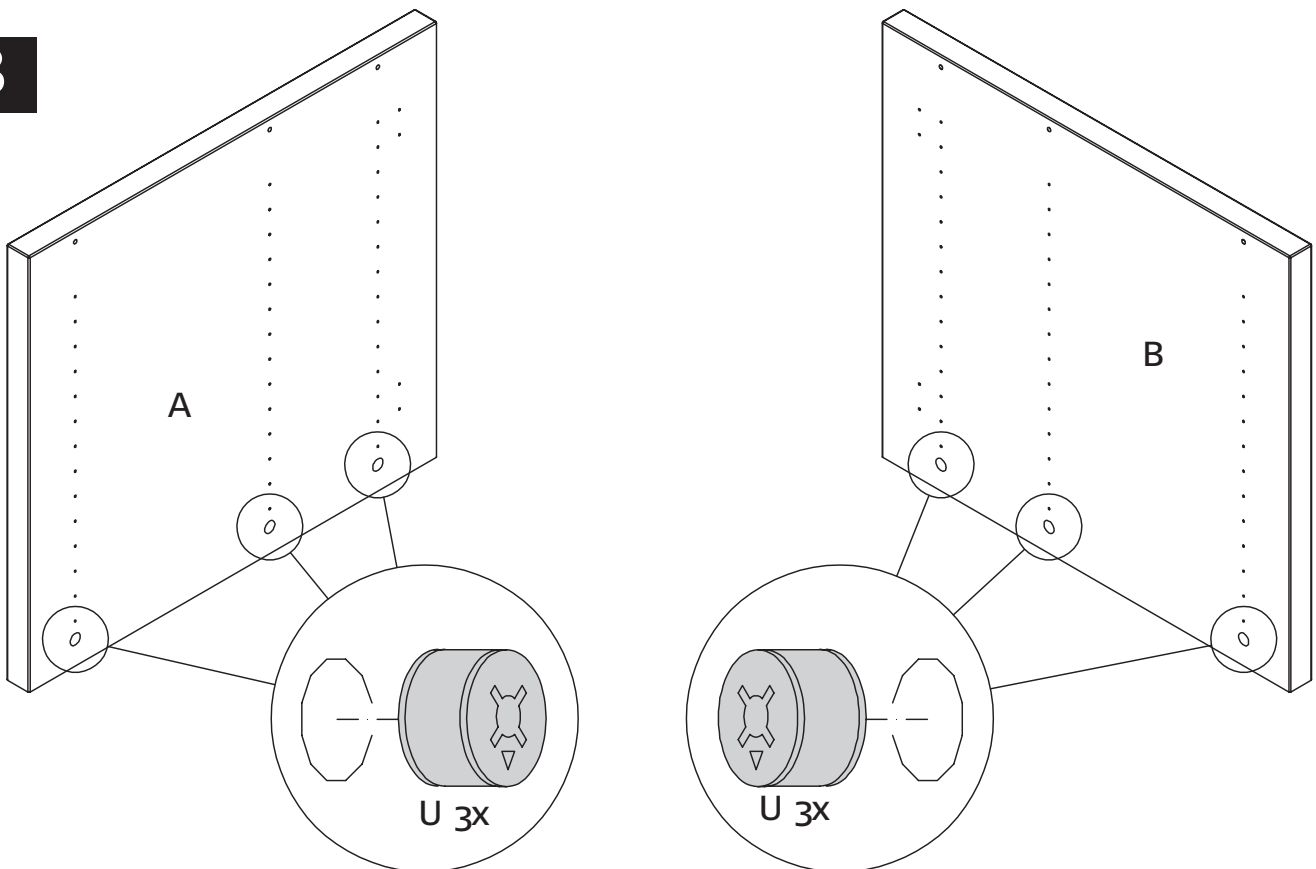

Markierungspfeil muß zur Bohrung in der Bauteilkante zeigen!

Arrow on cam must point to hole in the edge of the panel!

Placer la flèche repère au perçage sur le chant de l'élément!

Pijl in de kopse kant van betreffende onderdeel wijzen!

**MONTAGEANLEITUNG
MULTIFUNKTIONSCONTAINER
TYP 7720 / 7722**

MULTI-FUNCTIONAL CONTAINER
CONTAINER MULTI-FONCTIONS
MULTIFUNCTIE-CONTAINER



MONTAGE · ASSEMBLY · MONTAGE · MONTAGE

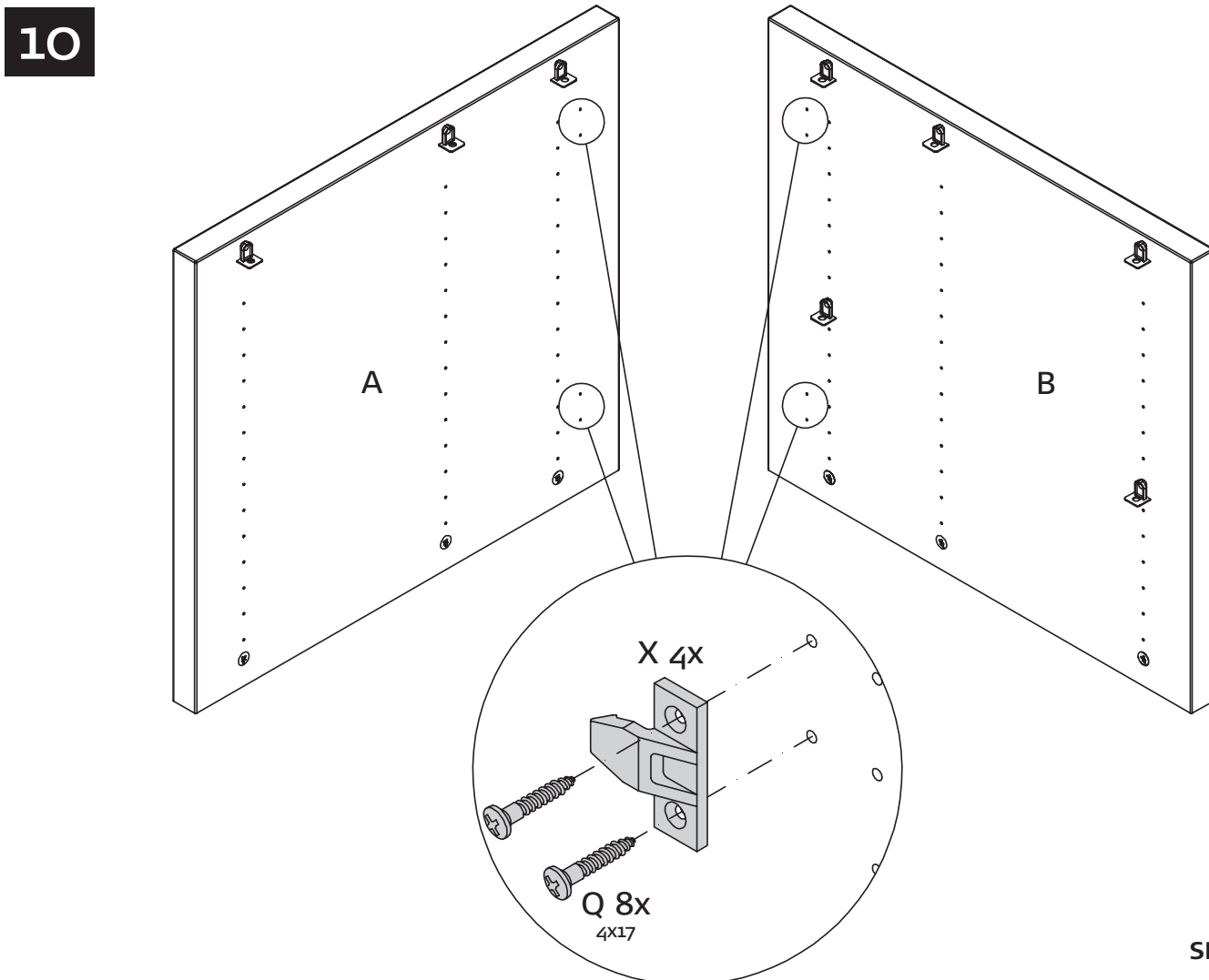
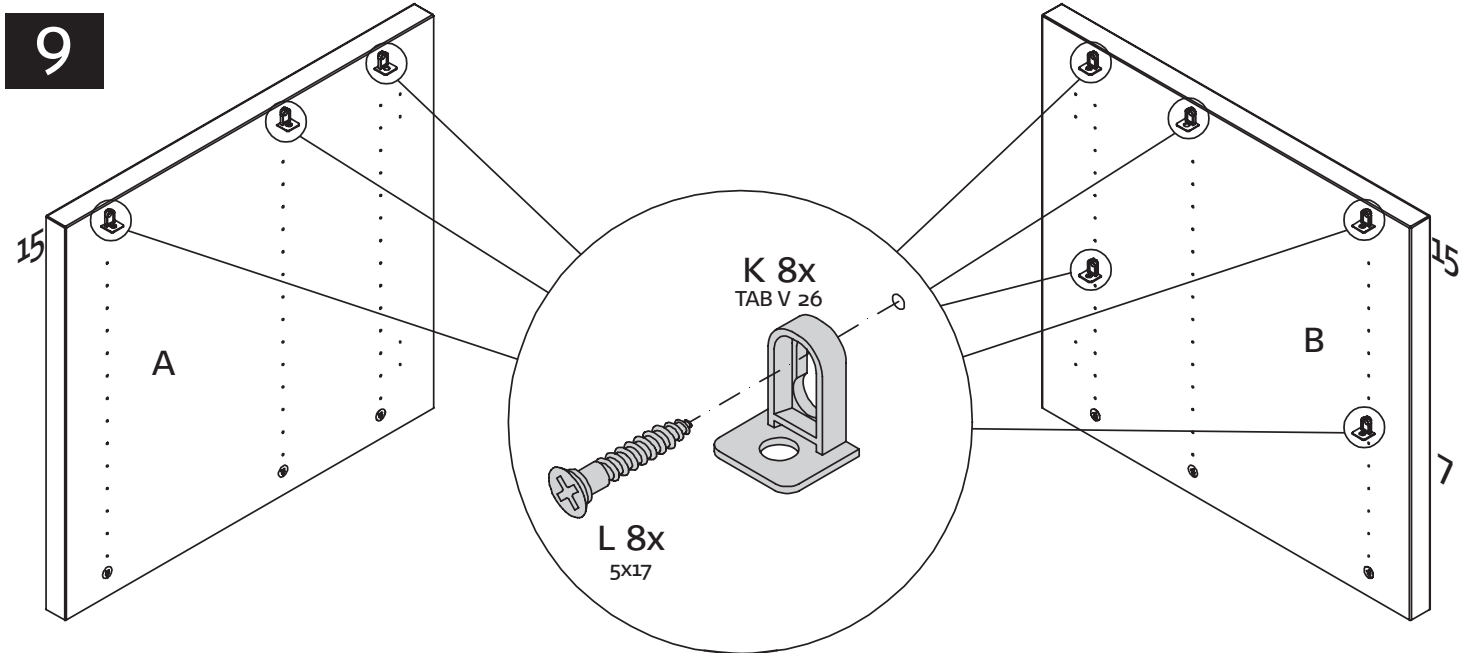

MONTAGEANLEITUNG MULTIFUNKTIONSCONTAINER TYP 7720 / 7722

MULTI-FUNCTIONAL CONTAINER
CONTAINER MULTI-FONCTIONS
MULTIFUNCTIE-CONTAINER

now! no.12
by hülsta

MONTAGE · ASSEMBLY · MONTAGE · MONTAGE

11

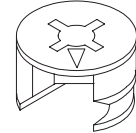
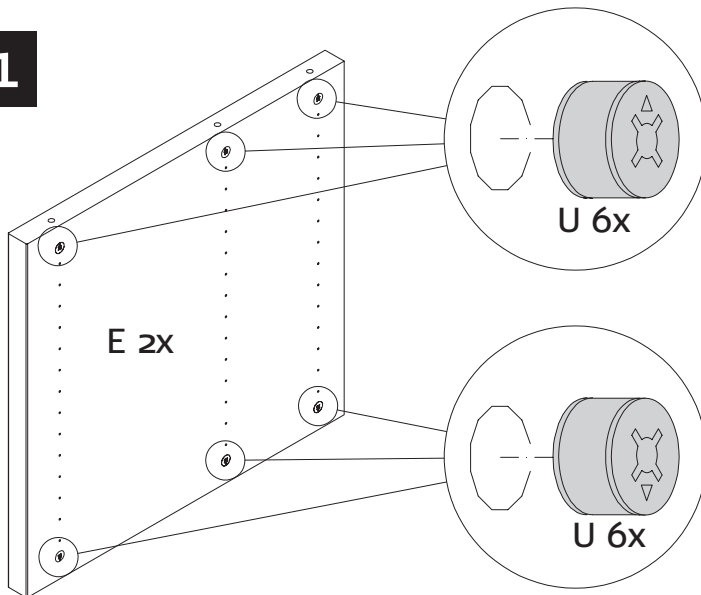

Markierungspfeil muß zur Bohrung in
der Bauteilkante zeigen!

Arrow on cam must point to hole in the edge of the panel!
Placer la flèche repère au perçage sur le chant de l'élément!
Pijl in de kopse kant van betreffende onderdeel wijzen!

12

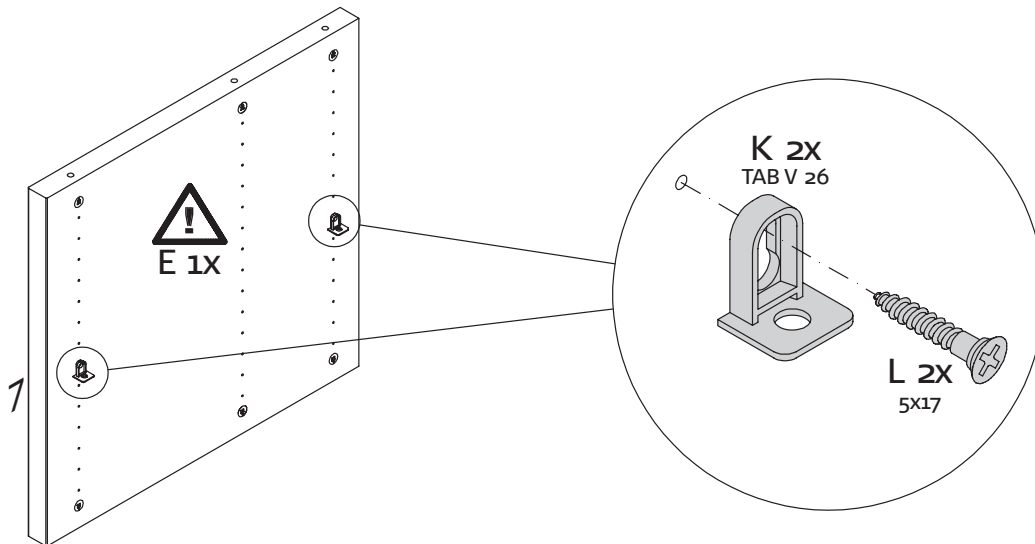

13

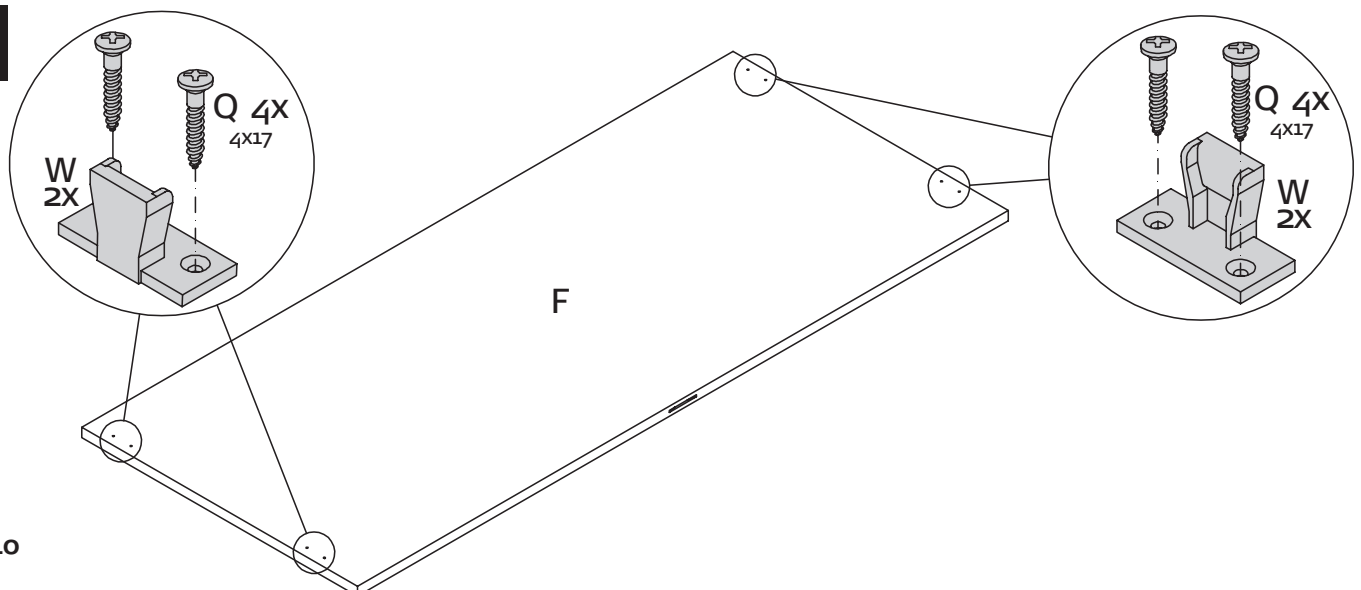

**MONTAGEANLEITUNG
MULTIFUNKTIONSCONTAINER
TYP 7720 / 7722**

MULTI-FUNCTIONAL CONTAINER
CONTAINER MULTI-FONCTIONS
MULTIFUNCTIE-CONTAINER



MONTAGE · ASSEMBLY · MONTAGE · MONTAGE

14

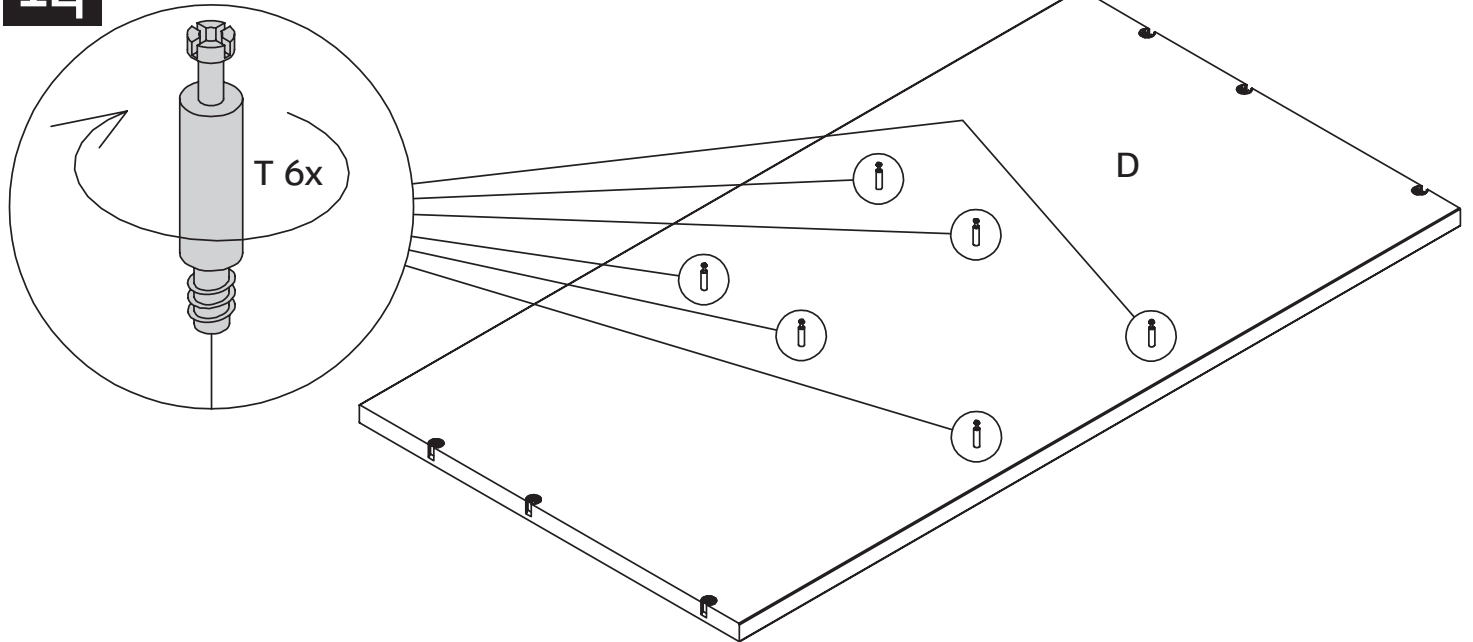

15

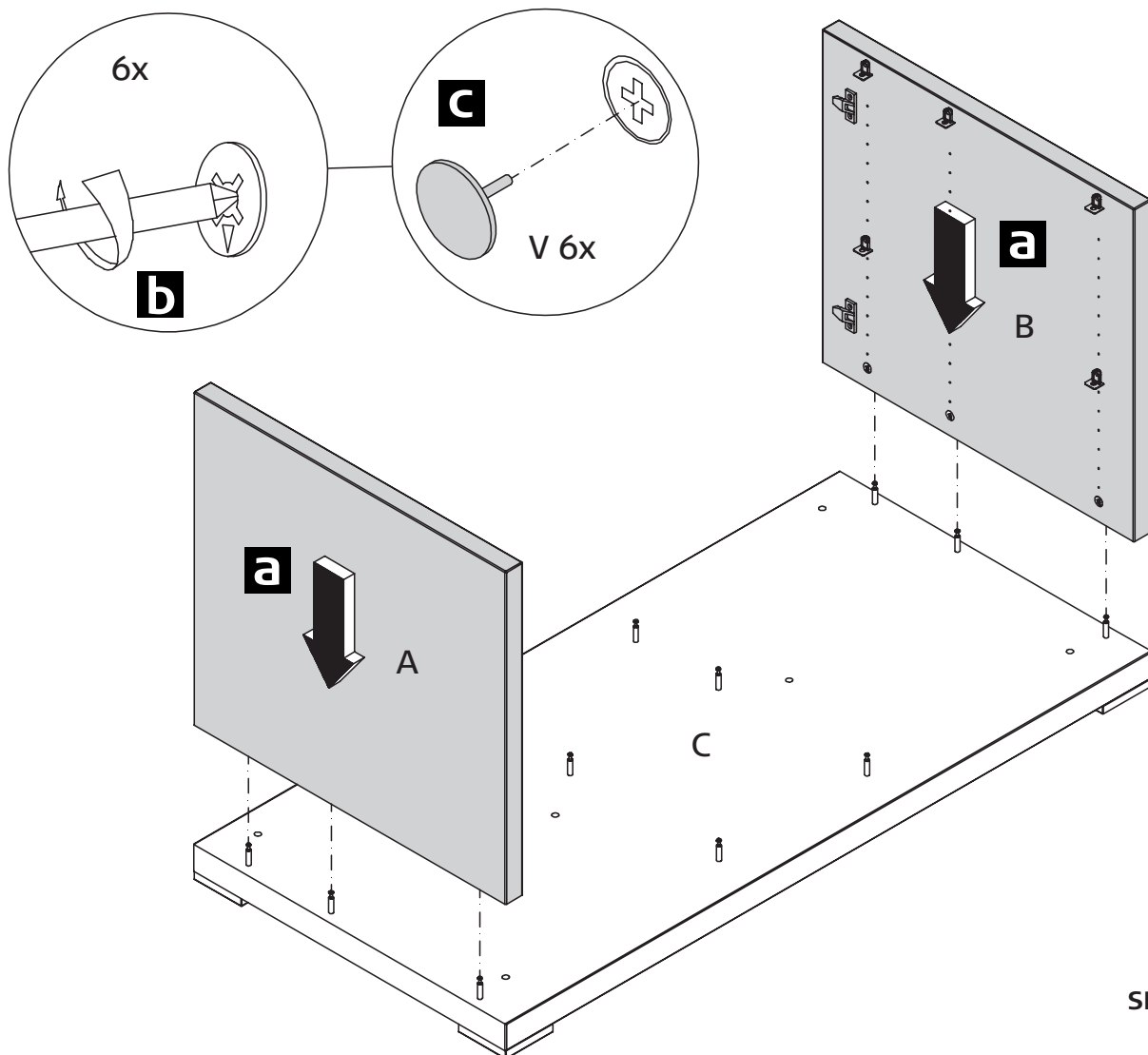

**MONTAGEANLEITUNG
MULTIFUNKTIONSCONTAINER
TYP 7720 / 7722**

MULTI-FUNCTIONAL CONTAINER
CONTAINER MULTI-FONCTIONS
MULTIFUNCTIE-CONTAINER

now! no.12
by hülsta

MONTAGE · ASSEMBLY · MONTAGE · MONTAGE

16

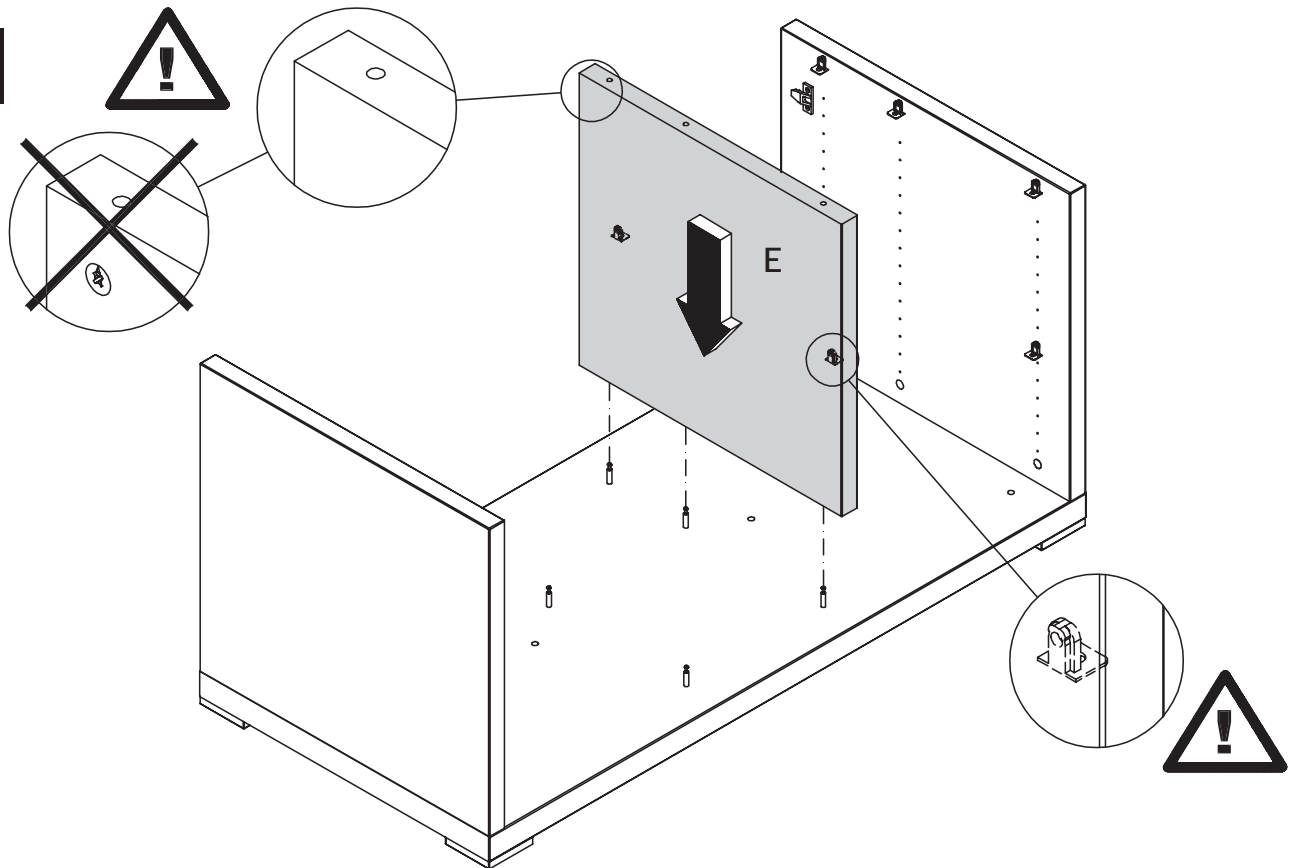

17

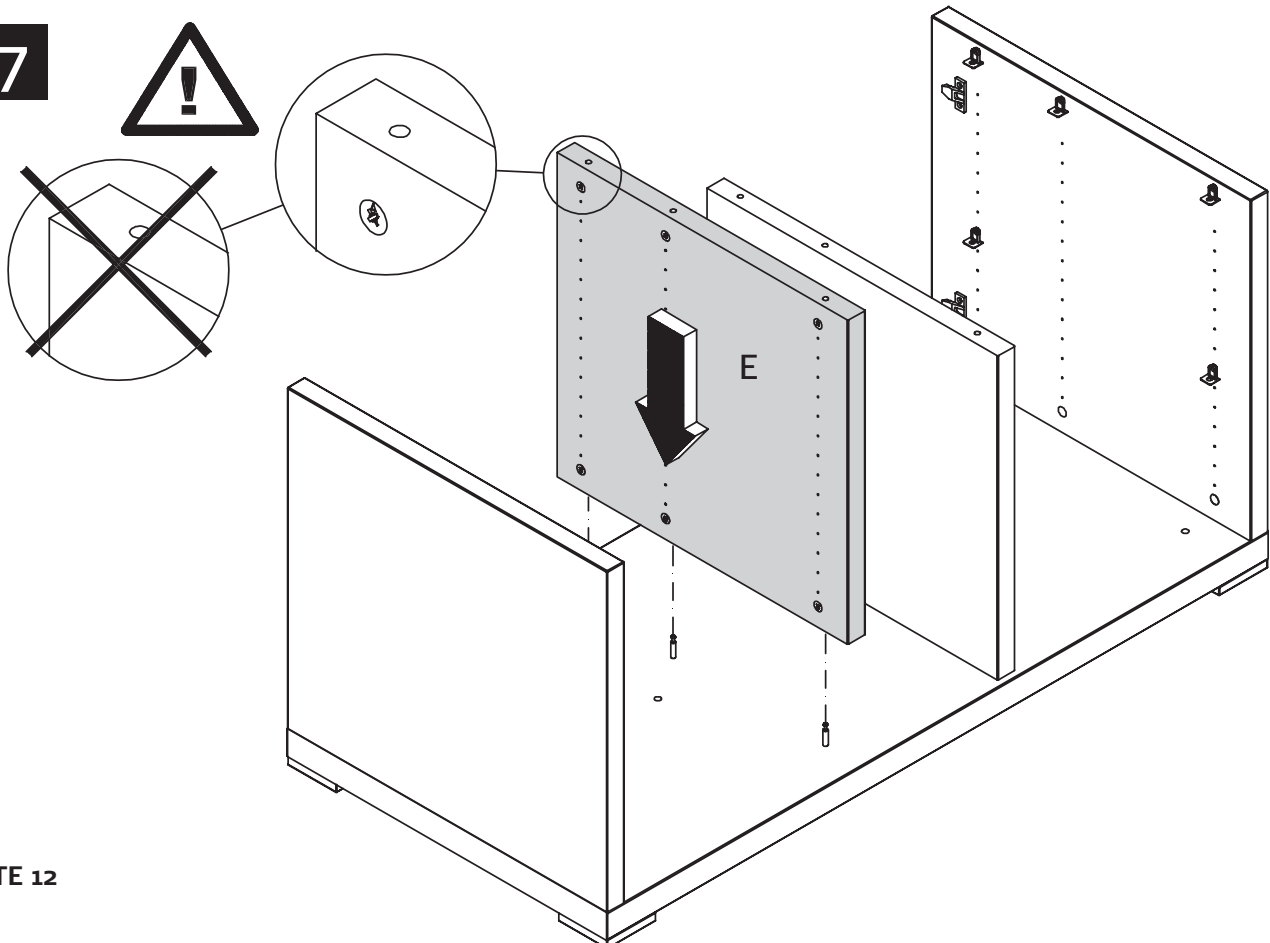

**MONTAGEANLEITUNG
MULTIFUNKTIONSCONTAINER
TYP 7720 / 7722**

MULTI-FUNCTIONAL CONTAINER
CONTAINER MULTI-FONCTIONS
MULTIFUNCTIE-CONTAINER

now! no.12
by hülsta

MONTAGE · ASSEMBLY · MONTAGE · MONTAGE

18

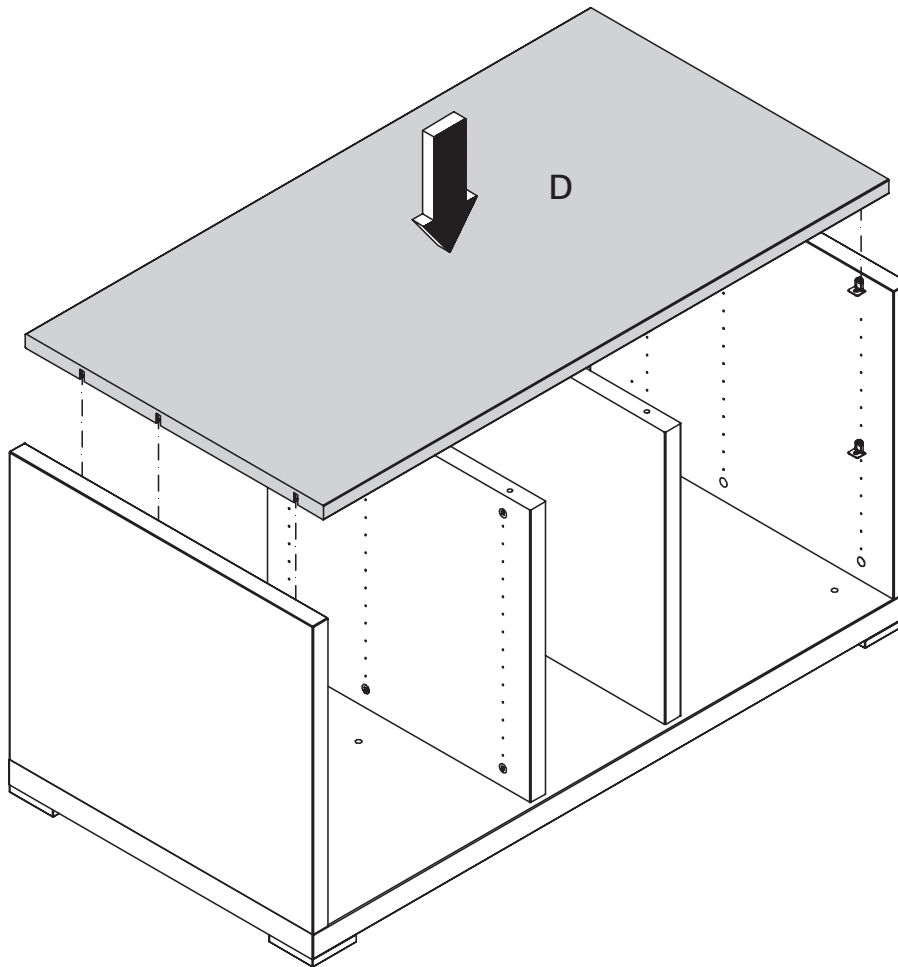

19

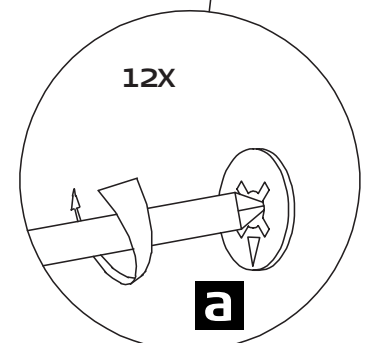
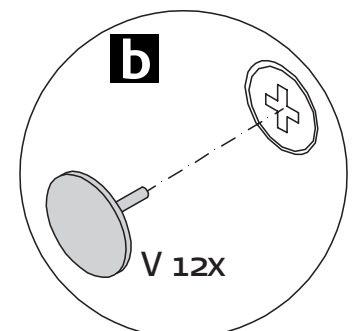
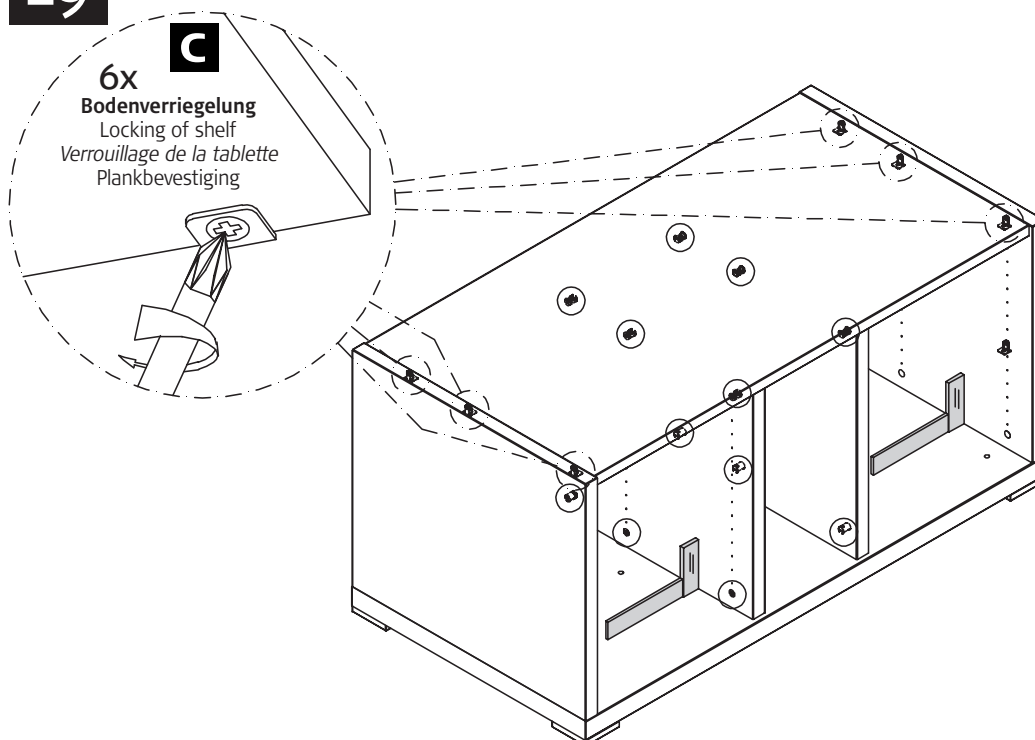

SEITE 13

MONTAGEANLEITUNG
MULTIFUNKTIONSCONTAINER
TYP 7720 / 7722

MULTI-FUNCTIONAL CONTAINER
CONTAINER MULTI-FONCTIONS
MULTIFUNCTIE-CONTAINER

now! no.12
by hülsta

MONTAGE · ASSEMBLY · MONTAGE · MONTAGE

20

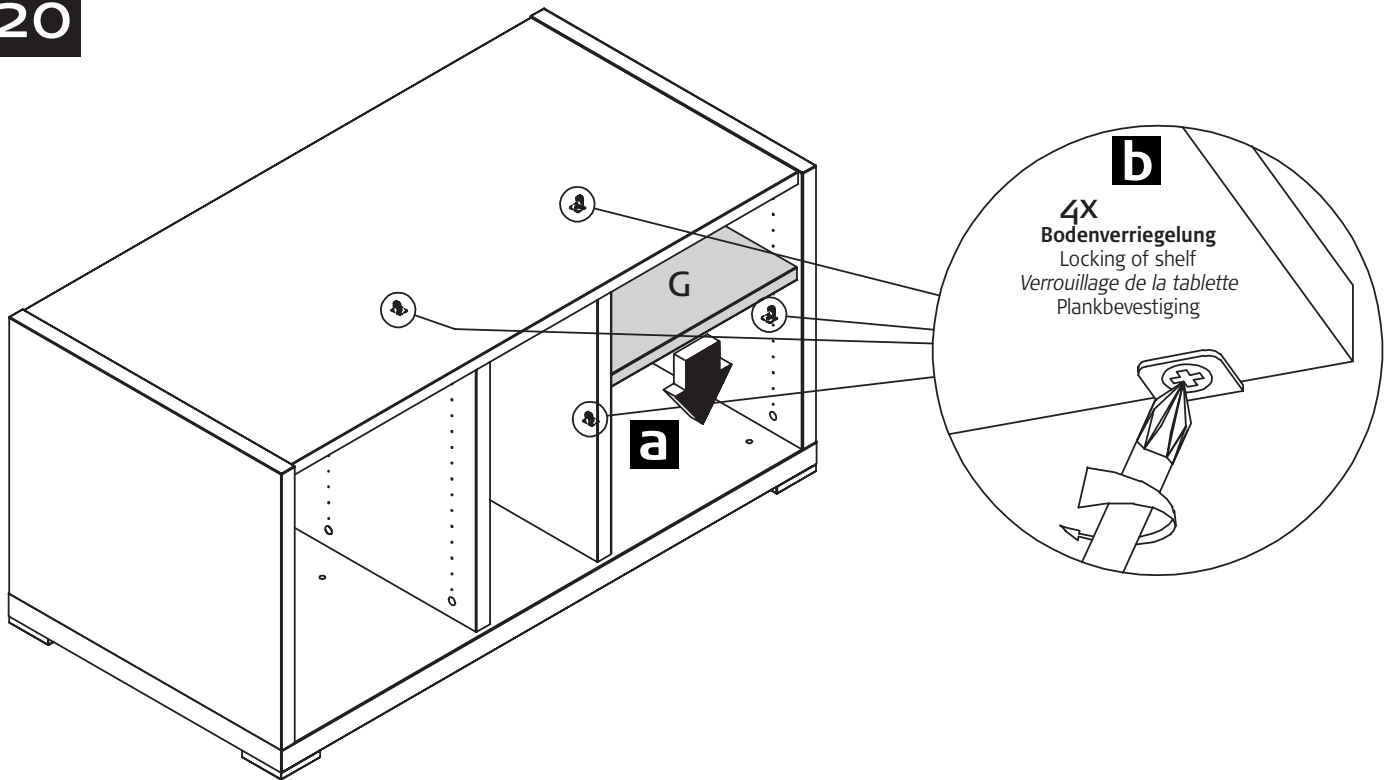

21

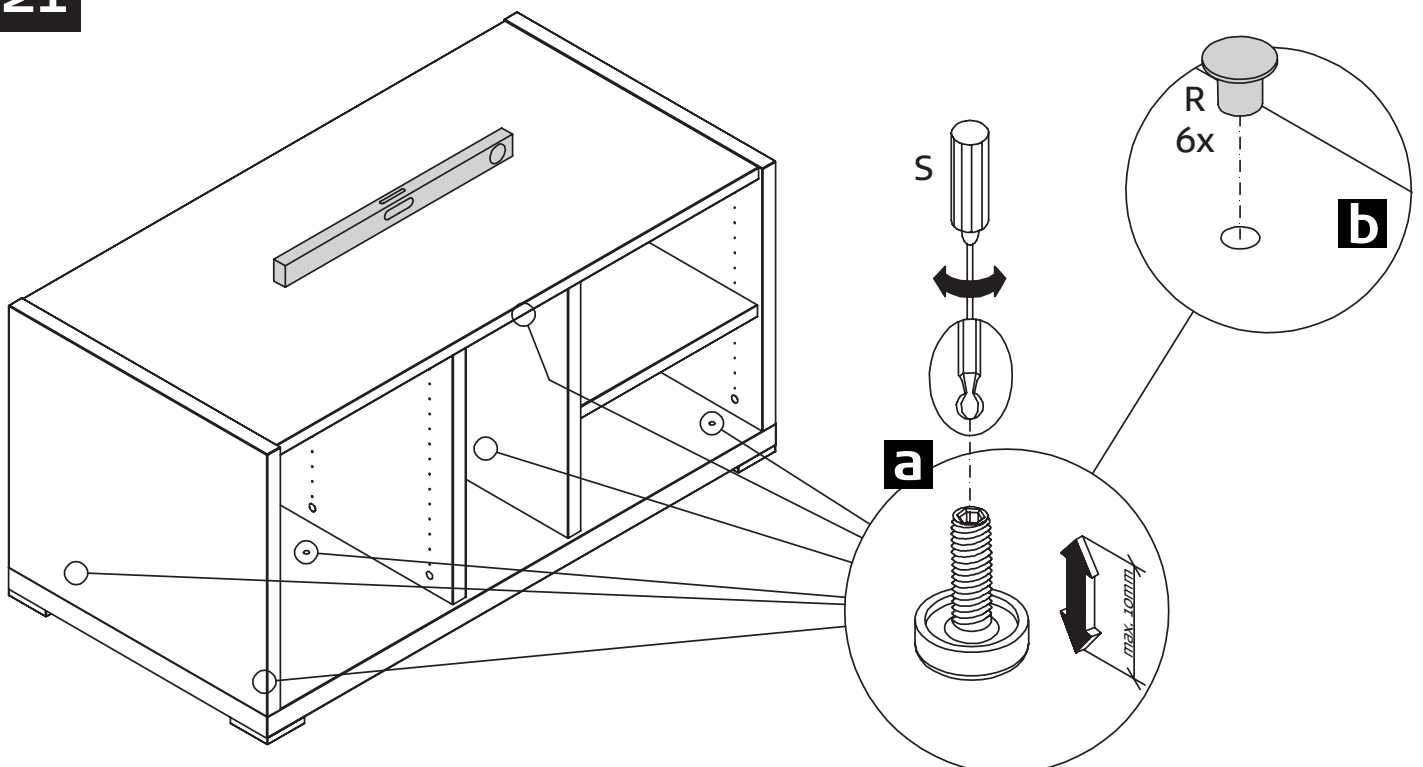

**MONTAGEANLEITUNG
MULTIFUNKTIONSCONTAINER
TYP 7720 / 7722**

MULTI-FUNCTIONAL CONTAINER
CONTAINER MULTI-FONCTIONS
MULTIFUNCTIE-CONTAINER



MONTAGE · ASSEMBLY · MONTAGE · MONTAGE

22

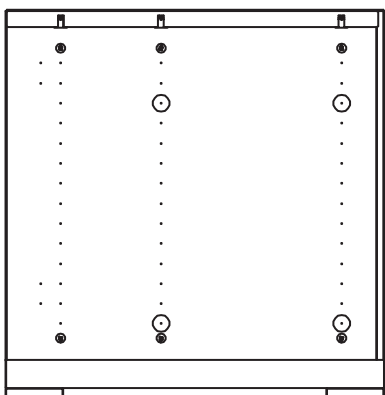
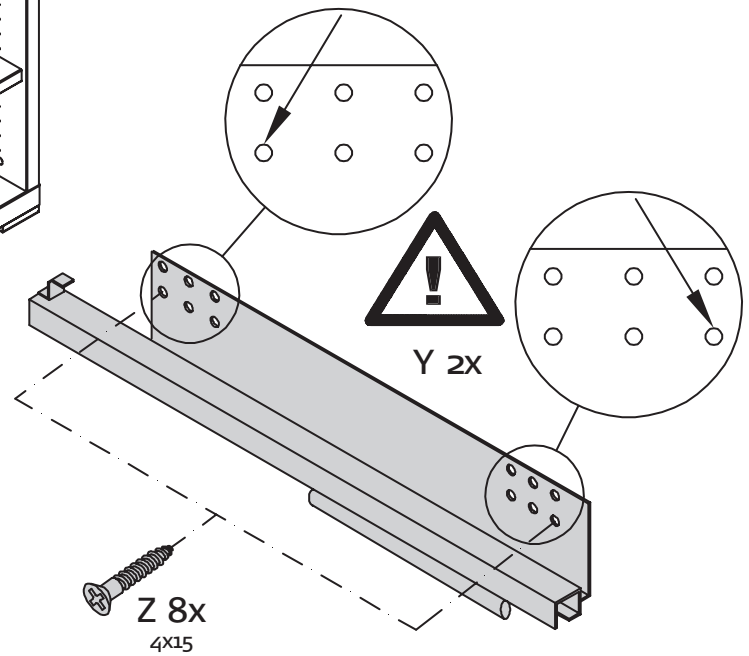
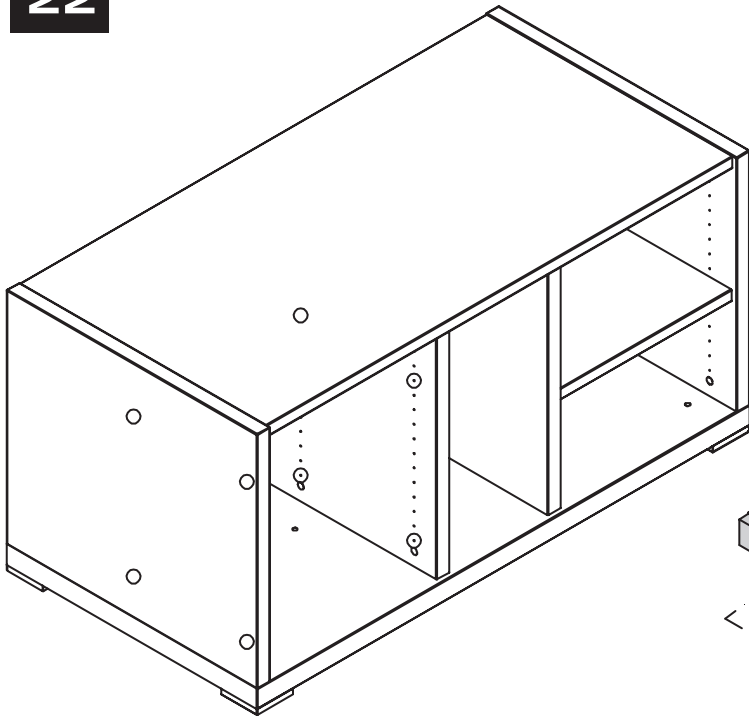

Linke Schubkastenschiene
Left drawer rail
Rail gauche du tiroir
Linker ladeloper

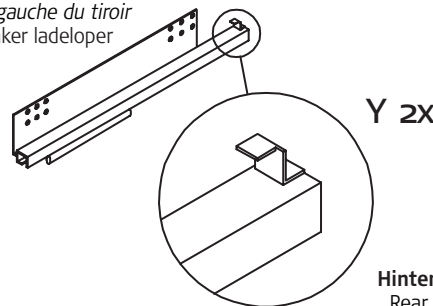

Rechte Schubkastenschiene
Right drawer rail
Rail droit du tiroir
Rechter ladeloper

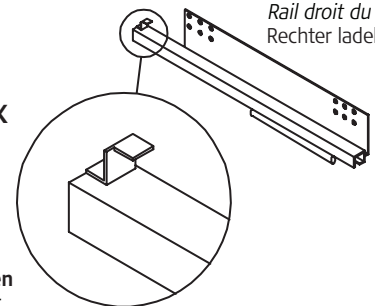

MONTAGEANLEITUNG MULTIFUNKTIONSCONTAINER TYP 7720 / 7722

MULTI-FUNCTIONAL CONTAINER
CONTAINER MULTI-FONCTIONS
MULTIFUNCTIE-CONTAINER

now! no.12
by hülsta

MONTAGE · ASSEMBLY · MONTAGE · MONTAGE

23

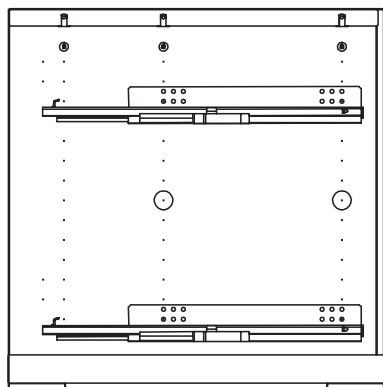
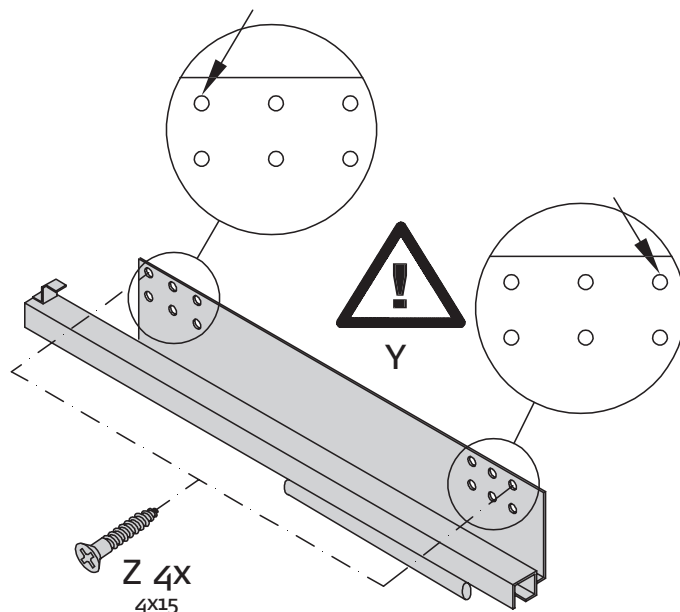
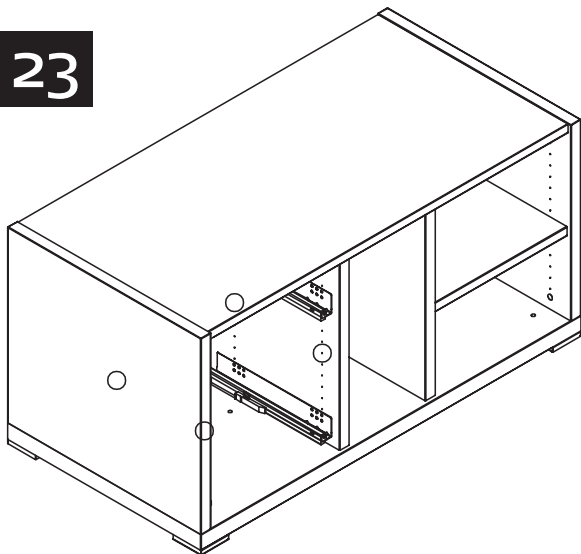

Linke Schubkastenschiene
Left drawer rail
Rail gauche du tiroir
Linker ladeloper

Rechte Schubkastenschiene
Right drawer rail
Rail droit du tiroir
Rechter ladeloper

7

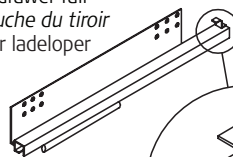

Y

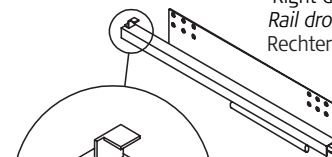

Hinten
Rear
Arrière
Achter

24

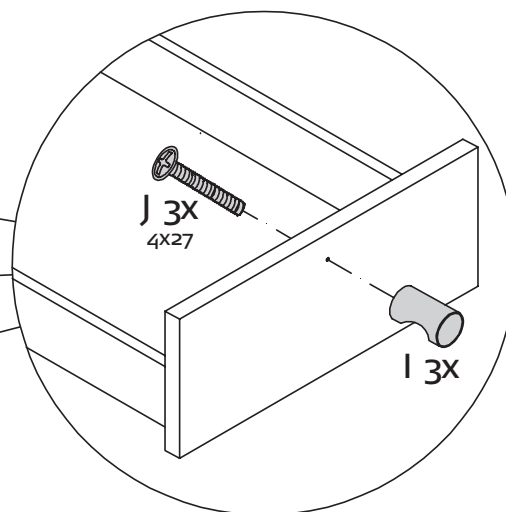
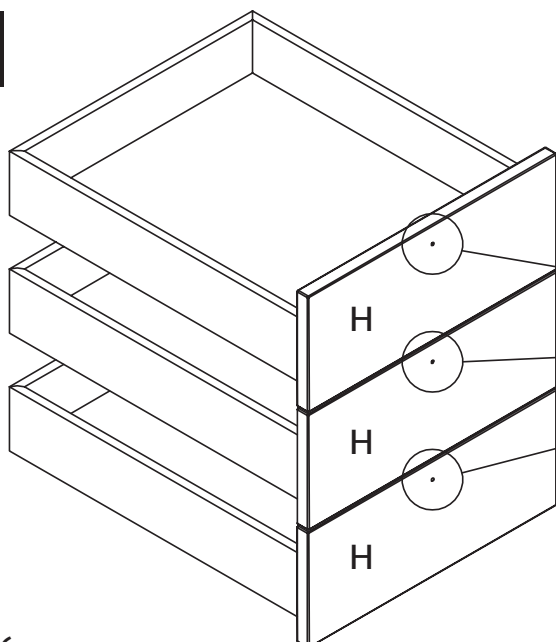

**MONTAGEANLEITUNG
MULTIFUNKTIONSCONTAINER
TYP 7720 / 7722**

MULTI-FUNCTIONAL CONTAINER
CONTAINER MULTI-FONCTIONS
MULTIFUNCTIE-CONTAINER

now! no.12
by hülsta

MONTAGE · ASSEMBLY · MONTAGE · MONTAGE

25

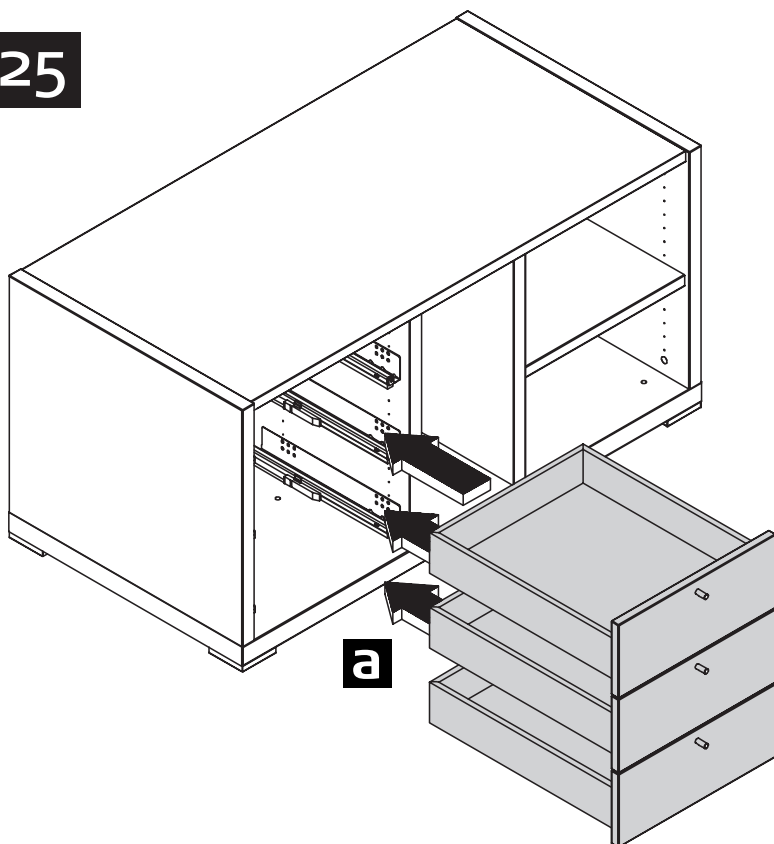

b



Aushängen des Schubkastens

Detaching the drawer
Dépose du tiroir
Lade demonteren

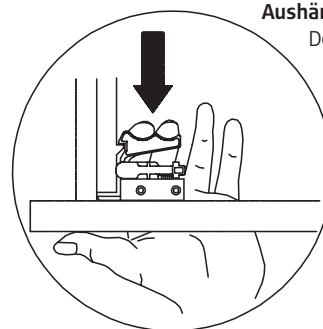

26

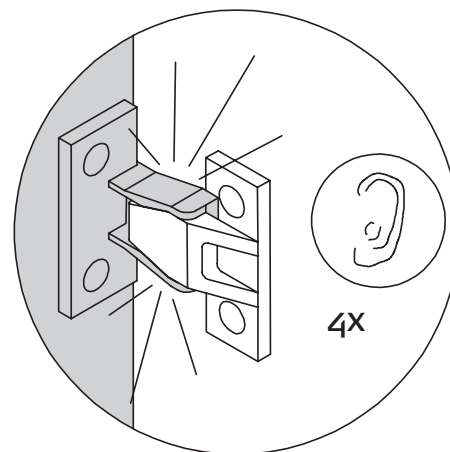
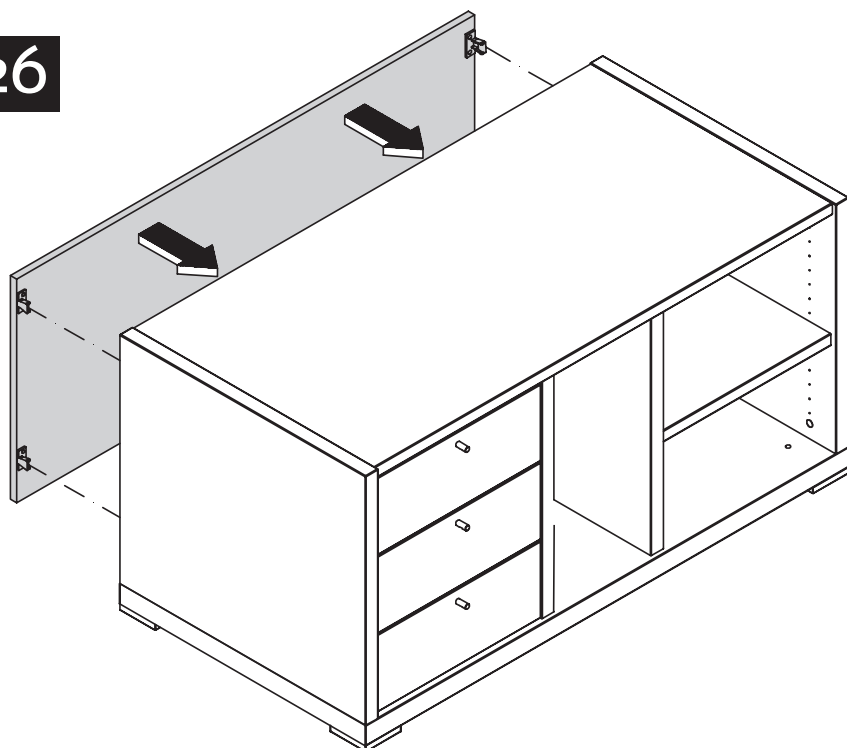

SERVICE

Stand: 03.2011

hülsta-werke · Karl-Hüls-Straße 1 · 48703 Stadthoorn
TEL.+49 2563 86-0 · FAX +49 2563 86-1417
www.huelsta.com · info@huelsta.com

Mat.Nr. 1261276

SEITE 17