



MONTAGEANLEITUNG Hängeelement 4R / 8R

TYP 4401 / 4402 / 4421 / 4422 / 4331 / 4332 / 4441 / 4442 /
4341L / 4342L / 4351R / 4352R / 4491 / 4492

WALL UNIT 4R / 8R
ELEMENT SUSPENDU 4U / 8U
HANGELEMENT 4R / 8R



MONTAGEANLEITUNG · ASSEMBLY INSTRUCTION · NOTICE DE MONTAGE · MONTAGEHANDLEIDING

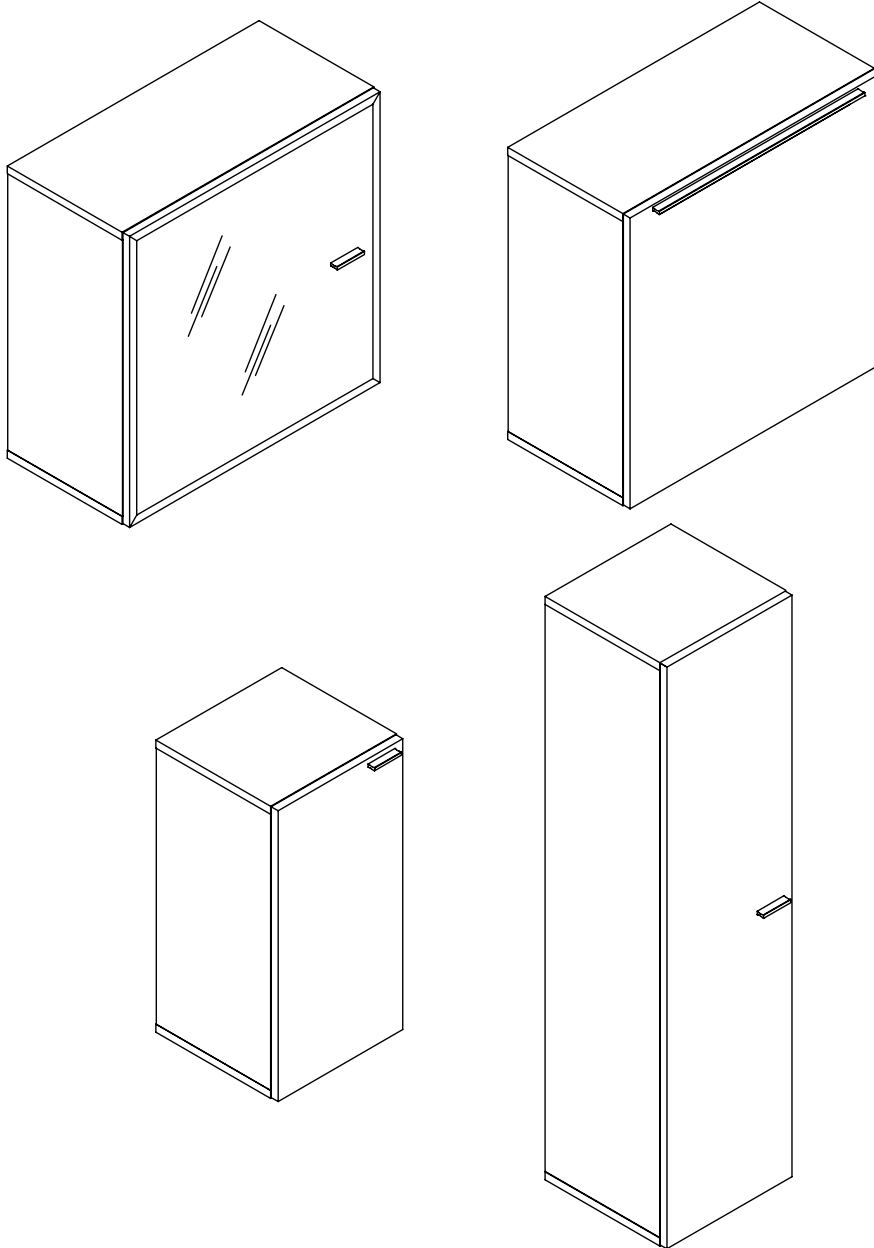

1358322

Lesen Sie zuerst die Anleitung und beginnen Sie dann mit der Montage

Before starting with the fitting, please read carefully the assembly instruction

Avant de commencer avec le montage, nous vous prions de bien lire le notice de montage

Voordat uw met de montage begint, a.u.b. de montagehandleiding lezen

MONTAGEANLEITUNG

Hängeelement 4R / 8R

TYP 4401 / 4402 / 4421 / 4422 / 4331 / 4332 / 4441 / 4442 /
4341L / 4342L / 4351R / 4352R / 4491 / 4492

WALL UNIT 4R / 8R
ELEMENT SUSPENDU 4U / 8U
HANGELEMENT 4R / 8R

now! by hülsta **no.7**

MONTAGEANLEITUNG · ASSEMBLY INSTRUCTION · NOTICE DE MONTAGE · MONTAGEHANDLEIDING

D:

Lieber now! by hülsta – Kunde,
sollten Sie – wider Erwarten – bei der Montage im Bereich der
beigepackten Beschläge Mängel in Form von:

- fehlenden Beschlagteilen
 - falschen Beschlagteilen
 - fehlerhaften Beschlagteilen (z.B. gebrochen, beschädigt o.ä.)
- feststellen, möchten wir Sie im Sinne einer zügigen und fehlerlosen
Abwicklung Ihrer Reklamation um folgende Angaben bitten:

1. Materialnummer des Beschlagkartons
2. Materialnummer und Stückzahl des Beschlagteils
3. Reklamationsgrund (z.B. fehlt, falsch, defekt, gebrochen...)
4. Packdatum (sofern vorhanden) der Beschlagkartonage
5. Prüfnummer (sofern vorhanden) auf dem Beschlagkarton

Diese Angaben können sie wahlweise per
E-mail: hotline@now.de

oder über die
now! by hülsta Servicehotline: 02563/ 86 – 1500
an uns weitergeben.

Mit freundlichen Grüßen
Ihr now! by hülsta - Team

GB:

Dear now! by hülsta customer,
If – contrary to expectations – there should be any discrepancies in the
accompanying fittings needed for assembly, such as:

- missing fittings
- incorrect fittings
- faulty fittings (e.g. broken, damaged, etc.)

we would like you to provide us with the following information so that your
complaint can be dealt with as quickly and successfully as possible:

1. Material number of fitting bracket packet
2. Material number and quantity of fitting brackets
3. Reason for complaint (e.g. part missing, incorrect, defective, broken...)
4. Date of packaging (if known) of fitting bracket packet
5. Check number (if known) on the fitting bracket packet

You can send us this data either by
e-mail: hotline@now.de
or by calling the
now! by hülsta service hotline: +49 (0) 2563 / 86 – 1500

With kind regards
Your now! by hülsta team

F:

Cher client now! by hülsta,
dans le cas où vous constateriez lors du montage, contrairement à nos intentions,
des anomalies dans le secteur des ferrures livrées se présentant sous les formes
suivantes:

- manque de certaines éléments des ferrures
- ferrures non adaptées
- éléments des ferrures défectueux (par exemple: cassées, abîmées ou similaires),
nous vous demandons de bien vouloir nous communiquer lors de votre réclamation
les données suivantes afin de permettre une réaction rapide et précise:

1. Référence du carton des ferrures
2. Référence et quantité de la pièce de la ferrure
3. Raison de la réclamation (par exemple: manque,
inadaptation, malfaçon, cassé ...)
4. Date d'emballage (si disponible) du carton des ferrures
5. Numéro de contrôle (si disponible) sur le carton de ferrures

Il vous est possible de nous communiquer ces données par
e-mail: hotline@now.de

ou en appelant notre
service hotline now! by hülsta: +49 (0) 2563 / 86 – 1500

Avec nos sincères salutations
L'équipe now! by hülsta

NL:

Geachte now! by hülsta-klant,
Indien u – tegen alle verwachtingen in – tijdens de montage m.b.t. de bijgepakte
beslagdelen klachten hebt, zoals:

- het ontbreken van bepaalde beslagdelen
- het onvoldoende ontvangen hebben van bepaalde beslagdelen
- of het hebben ontvangen van defecte beslagdelen

(bijv. gebroken of ernstig beschadigd),
dan verzoeken wij u – om uw reclamatie snel en correct te kunnen afwikkelen –
ons de volgende gegevens te verstrekken:

1. het materiaalnummer van de doos met beslagdelen
2. het materiaalnummer en het aantal stuks van de betr. beslagdelen
3. de reden van de reclamatie (bijv. ontbrak, verkeerd, defect, gebroken ...)
4. de inpakdatum op de doos met beslagdelen (indien voorhanden)
5. het controlnummer op de doos met beslagdelen (indien voorhanden)

Deze gegevens kunt u of per
e-mail: hotline@now.de

sturen, of per
now! by hülsta servicehotline: +49 (0) 2563 / 86 – 1500
telefonisch doorgeven.

Met vriendelijke groeten,
uw now! by hülsta-team

Angaben auf der Beschlagkartonage:

Data on fitting bracket packet:
Données sur le carton des ferrures:
Gegevens op de beslagdelendoos:

1. Materialnummer Beschlagkarton

1. Material number of fitting bracket packet
1. Référence du carton des ferrures
1. Materialnummer beslagdelendoos

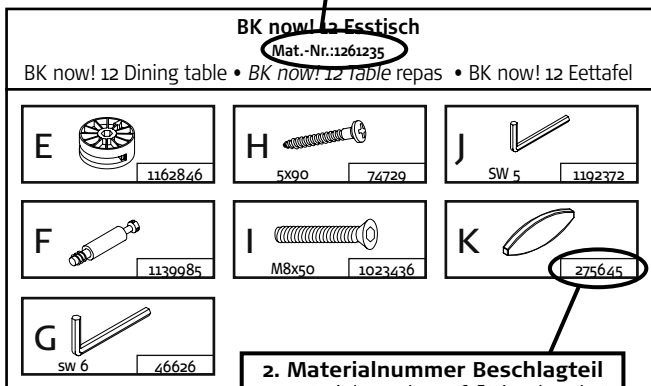

2. Materialnummer Beschlagteil
2. Référence de la pièce de la ferrure
2. Materiaalnummer beslagdeel

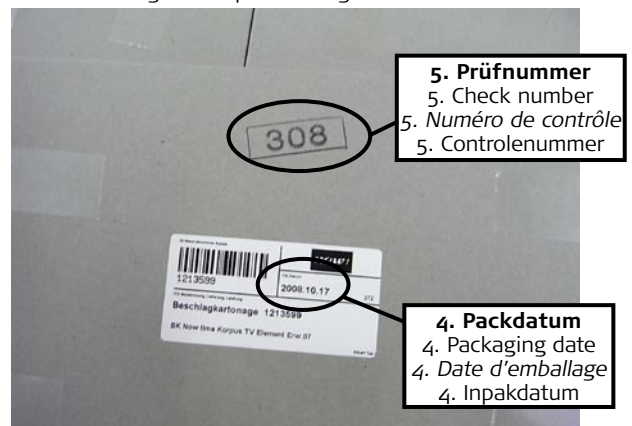

5. Prüfnummer
5. Check number
5. Numéro de contrôle
5. Controlnummer

4. Packdatum
4. Packaging date
4. Date d'emballage
4. Inpakdatum

MONTAGEANLEITUNG

Hängeelement 4R / 8R

TYP 4401 / 4402 / 4421 / 4422 / 4331 / 4332 / 4441 / 4442 /
4341L / 4342L / 4351R / 4352R / 4491 / 4492

WALL UNIT 4R / 8R

ELEMENT SUSPENDU 4U / 8U

HANGELEMENT 4R / 8R



INHALT · CONTENTS · TABLE DES MATIERES · INHOUD

INHALT · CONTENTS · TABLE DES MATIERS · INHOUD

SEITE · PAGE · PAGE · BLADZIJDE

Gesamtübersicht Hängeelement 4R 70er Breite Summary wall unit 4R, 70 cm wide · <i>Vue générale élément suspendu 4U, 70 cm de largeur</i> · Totaaloverzicht hangelement 4R, 70 cm breed	4-5
Gesamtübersicht Hängeelement 4R 35er Breite Summary wall unit 4R, 35 cm wide · <i>Vue générale élément suspendu 4U, 35 cm de largeur</i> · Totaaloverzicht hangelement 4R, 35 cm breed	6-7
Gesamtübersicht Hängeelement 8R 35er Breite Summary wall unit 8R, 35 cm wide · <i>Vue générale élément suspendu 8U, 35 cm de largeur</i> · Totaaloverzicht hangelement 8R, 35 cm breed	8-9
Korpus Carcase · <i>Corps</i> · Romp	10-11
Holztür / -einlegeboden Wooden door and wooden shelf · <i>Porte en bois et tablette en bois</i> · Houten deur en houten plank	12-19
Glastür / -einlegeboden Glass door and glass shelf · <i>Porte en verre et tablette en verre</i> · Glasdeur en glazen legger	20-22
Aufhängung Wall assembly · <i>Fixation murale</i> · Wandbevestiging	23-26

MONTAGEANLEITUNG

Hängeelement 4R 70er Breite

TYP 4331 / 4332 / 4441 / 4442 / 4341L / 4342L / 4351R / 4352R







WALL UNIT 4R, 70 CM WIDE
ELEMENT SUSPENDU 4U, 70 CM DE LARGE
HANGELEMENT 4R, 70 CM BREED

now!
by hülsta





no.7

GESAMTÜBERSICHT · SUMMARY · VUE GENERALE · TOTAALOVERZICHT



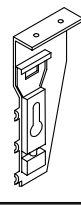

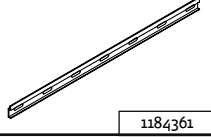
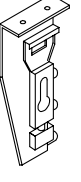

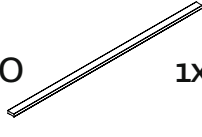

BK now! 7 Korpus Hänger Tür
Mat.-Nr.: 1174526
BK now! 7 Carcase wall unit door
BK now! 7 Corps élément suspendu porte
BK now! 7 Romp hangelement deur

A  8x 16154	E  8x 598798
B  Ø 15x16 353643	F  4x 937822 Weiß • White • Blanc • Wit 937820 Schwarz • Black • Noir • Zwart
C  4x 275556	G  8x 1120627 Weiß • White • Blanc • Wit 1120625 Schwarz • Black • Noir • Zwart
D  20x 275795	

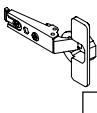







BK now! 7 Hängebeschlag
Mat.-Nr.: H59060000
BK now! 7 Mounting bracket
BK now! 7 Ferrure pour fixation murale
BK now! 7 Hangbevestiging

H  1x 911884	K  4x Ø 8mm 275620	N  1x 1184361
J  1x 911885	L  4x 3.5x13 275712	
	M  4x 5x60 176251	

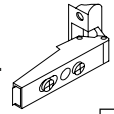
BK now! 7 Holzfront
Mat.-Nr.: 1174524
BK now! 7 Wooden front
BK now! 7 Façade en bois
BK now! 7 Houten front

O  1x 1170852	R  4x 4x15 936774
P  2x 1032832	S  3x M4x25 456264
Q  2x 1032845	T  4x 121192
	U  1x 1306325
	V  1x 1150790

BK now! 7 Glasfront
Mat.-Nr.: 1174525
BK now! 7 Glass front
BK now! 7 Façade en verre
BK now! 7 Glasfront

Q  2x 1032845	E1  4x M3x8 16751
R  4x 4x15 936774	F1  2x 1034299
T  4x 121192	G1  2x 375966
D1  1x 1170857	H1  2x M4x12 433290
	J1  2x 708423

Verehrter Kunde, hier haben Sie die Möglichkeit die mitgelieferten Schrauben nachzumessen!

Dear customer, here you find a possibility to measure the delivered screws!

Cher client, ici vous avez la possibilité de mesurer les vis livrées!

SEITE 4 Beste klant, hier heeft uw de mogelijkheid de schroeven te meten!



MONTAGEANLEITUNG

Hängeelement 4R 70er Breite

TYP 4331 / 4332 / 4441 / 4442 / 4341L / 4342L / 4351R / 4352R

WALL UNIT 4R, 70 CM WIDE
ELEMENT SUSPENDU 4U, 70 CM DE LARGE
HANGELEMENT 4R, 70 CM BREED

now!
by hülsta

no.7

GESAMTÜBERSICHT · SUMMARY · VUE GENERALE · TOTAALOVERZICHT

Für die Montage wird benötigt:

Necessary for assembly:

Pour le montage il faut:

Benodigdheden voor de montage:

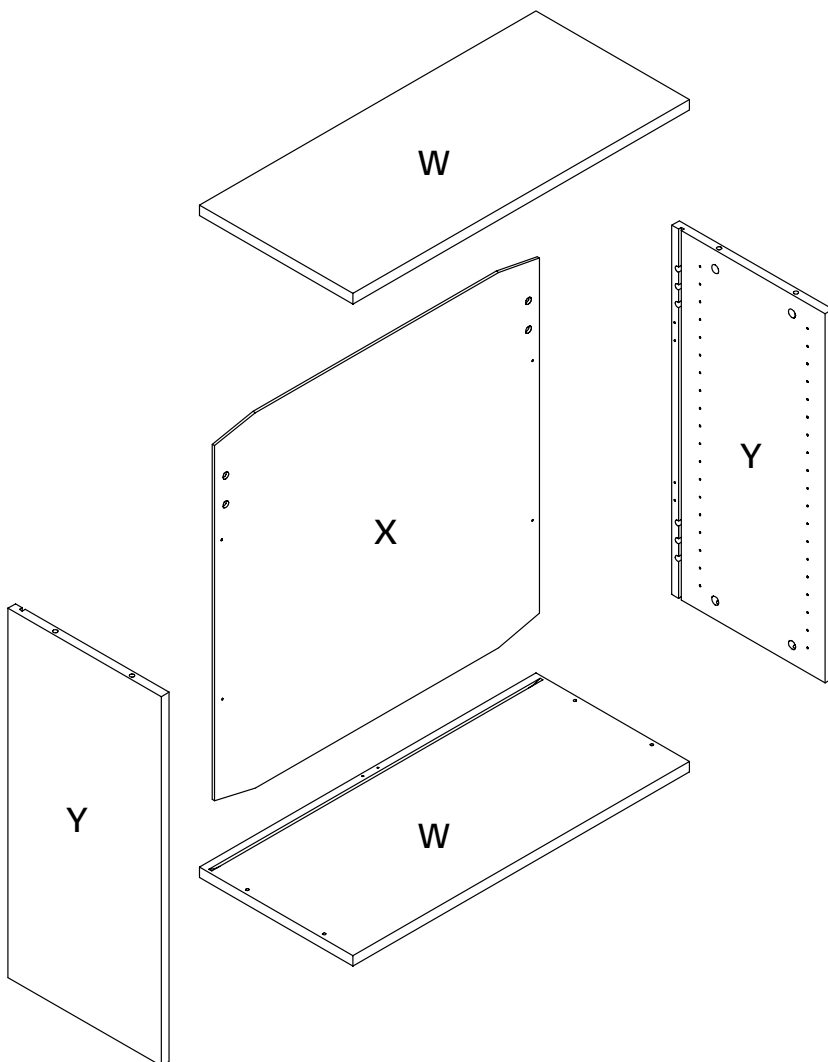
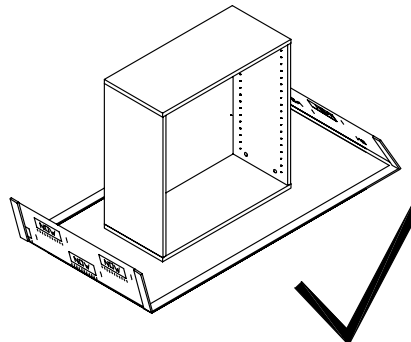
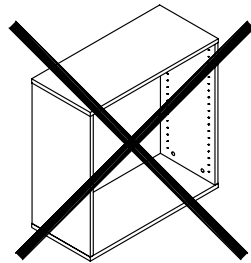
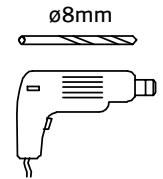
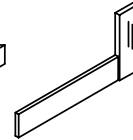
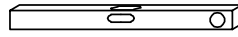
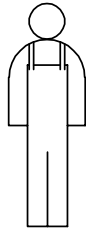

Holztür/ -einlegeboden

Wooden door and wooden shelf
Porte en bois et tablette en bois
Houten deur en houten plank

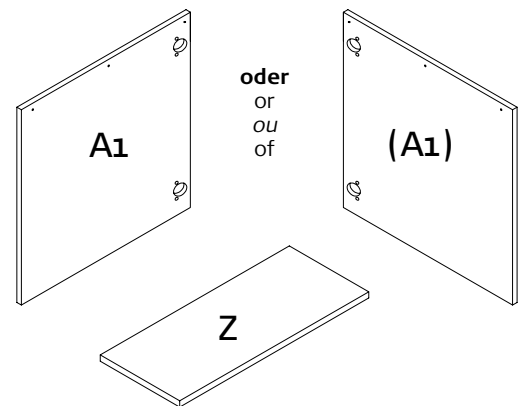

Glastür/ -einlegeboden

Glass door and glass shelf
Porte en verre et tablette en verre
Glasdeur en glazen legger

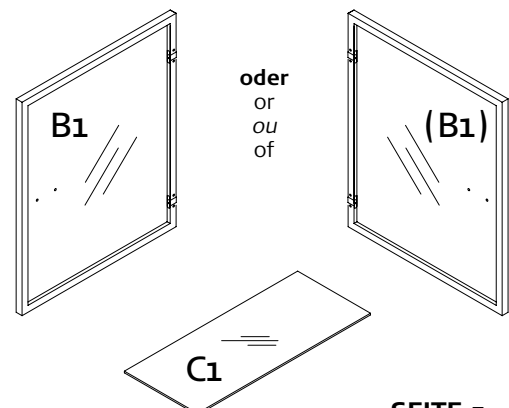

MONTAGEANLEITUNG Hängeelement 4R 35er Breite











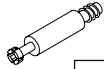

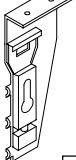

TYP 4401 / 4402 / 4421 / 4422

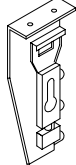





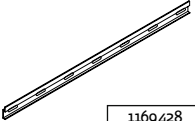

WALL UNIT 4R, 35 CM WIDE
ELEMENT SUSPENDU 4U, 35 CM DE LARGE
HANGELEMENT 4R, 35 CM BREED

now!
by hülsta

no.7

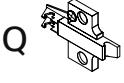
GESAMTÜBERSICHT · SUMMARY · VUE GENERALE · TOTAALOVERZICHT

BK now! 7 Korpus Hänger 350 Mat.-Nr.: 1358329 BK now! 7 Carcase wall unit, 35 cm wide BK now! 7 Corps élément suspendu, 35 cm de large BK now! 7 Romp hangelement, 35 cm breed				
A  8X 16154	E  12X 598798	H  1X 911884	K  4X ø 8mm 275620	K1  1X 1253304
B  8X ø 15x16 353643	F  6X 937822 Weiß • White • Blanc • Wit 937820 Schwarz • Black • Noir • Zwart	J  1X 911885	L  4X 3,5x13 275712	L1  1X ø 6mm 1119281
C  4X 275556	G  10X 1120627 Weiß • White • Blanc • Wit 1120625 Schwarz • Black • Noir • Zwart	M  5X 5x60 176251	N  1X 1169428	
D  26X 3,5x15 275795				

BK now! 7 Holzfront 4R 350 Mat.-Nr.: 1358330 BK now! 7 Wooden front 4R, 35 cm wide BK now! 7 Façade en bois 4U, 35 cm de large BK now! 7 Houten front 4R, 35 cm breed	
D1  1X 1170857	R  4X 4x15 936774
P  2X 1032832	S  2X M4x25 456264
Q  2X 1032845	T  4X 121192
	U  1X 1306325
	V  1X 1150790

Verehrter Kunde, hier haben Sie die Möglichkeit die mitgelieferten Schrauben nachzumessen!

Dear customer, here you find a possibility to measure the delivered screws!

Cher client, ici vous avez la possibilité de mesurer les vis livrées!

Beste klant, hier heeft uw de mogelijkheid de schroeven te meten!



MONTAGEANLEITUNG Hängeelement 4R 35er Breite

TYP 4401 / 4402 / 4421 / 4422

WALL UNIT 4R, 35 CM WIDE
ELEMENT SUSPENDU 4U, 35 CM DE LARGE
HANGELEMENT 4R, 35 CM BREED



GESAMTÜBERSICHT · SUMMARY · VUE GENERALE · TOTAALOVERZICHT

Für die Montage wird benötigt:

Necessary for assembly:

Pour le montage il faut:

Benodigdheden voor de montage:

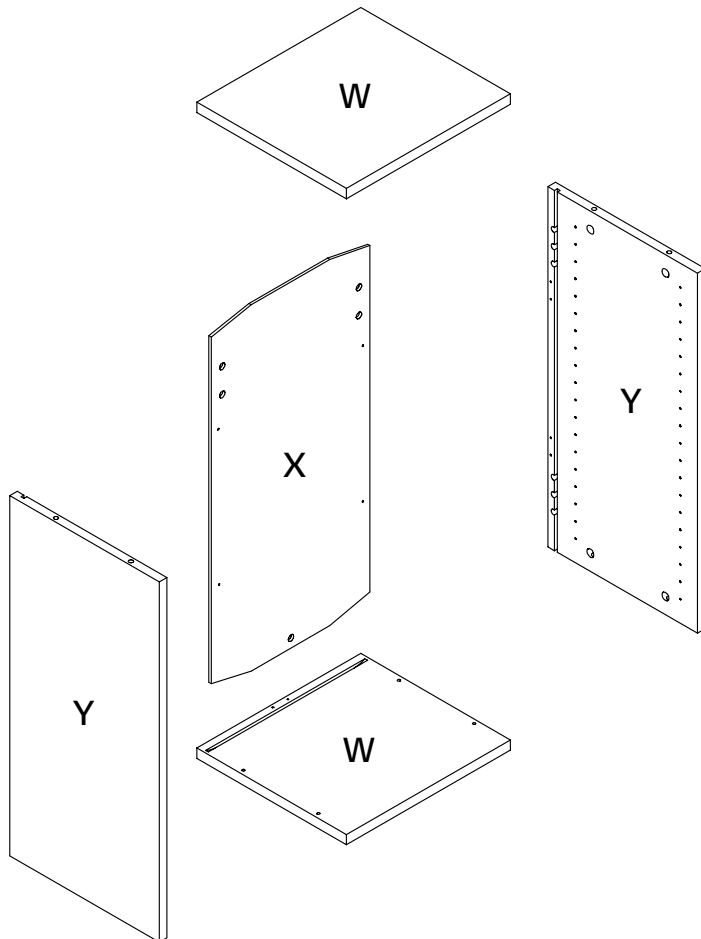
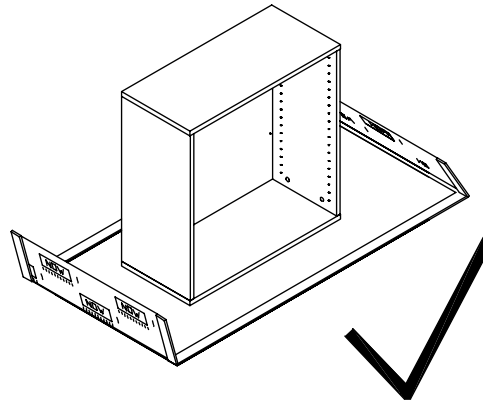
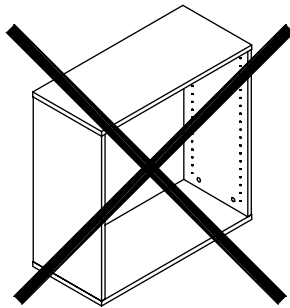
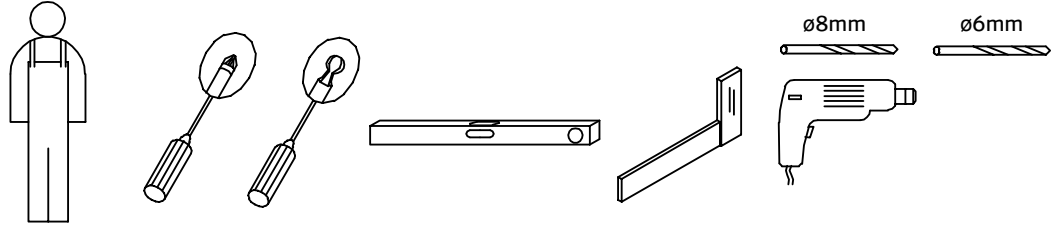

Holztür/ -einlegeboden
Wooden door and wooden shelf
Porte en bois et tablette en bois
Houten deur en houten plank

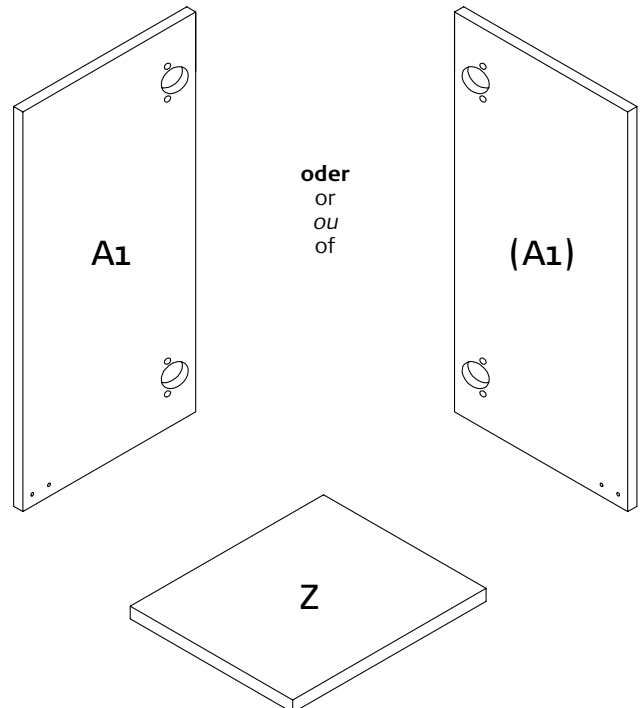

MONTAGEANLEITUNG

Hängeelement 8R 35er Breite











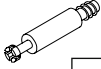

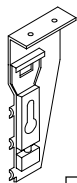

TYP 4491 / 4492

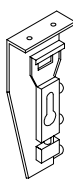





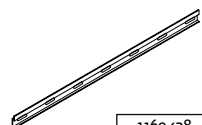

WALL UNIT 8R, 35 CM WIDE
ELEMENT SUSPENDU 8U, 35 CM DE LARGE
HANGELEMENT 8R, 35 CM BREED

now!
by hülsta

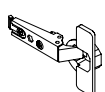
no.7

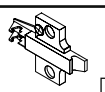
GESAMTÜBERSICHT · SUMMARY · VUE GENERALE · TOTAALOVERZICHT

BK now! 7 Korpus Hänger 350 Mat.-Nr.: 1358329 BK now! 7 Carcase wall unit, 35 cm wide BK now! 7 Corps élément suspendu, 35 cm de large BK now! 7 Romp hangelement, 35 cm breed				
A  8x 16154	E  12X 598798	H  1X 911884	K  4X ø 8mm 275620	K1  1X 1253304
B  8x ø 15x16 353643	F  6x 937822 Weiß • White • Blanc • Wit 937820 Schwarz • Black • Noir • Zwart	J  1X 911885	L  4X 3.5x13 275712	L1  1X ø 6mm 1119281
C  4X 275556	G  10X 1120627 Weiß • White • Blanc • Wit 1120625 Schwarz • Black • Noir • Zwart	M  5X 5x60 176251	N  1X 1169428	
D  26X 3.5x15 275795				

BK now! 7 Holzfront 8R 350 Mat.-Nr.: 1358341 BK now! 7 Wooden front 8R, 35 cm wide BK now! 7 Façade en bois 8U, 35 cm de large BK now! 7 Houten front 8R, 35 cm breed	
D1  1X 1170857	R  8X 4x15 936774
P  4X 1032832	S  2X M4x25 456264
Q  4X 1032845	T  4X 121192
	U  2X 1306325
	V  2X 1150790

Verehrter Kunde, hier haben Sie die Möglichkeit die mitgelieferten Schrauben nachzumessen!

Dear customer, here you find a possibility to measure the delivered screws!

Cher client, ici vous avez la possibilité de mesurer les vis livrées!

Beste klant, hier heeft uw de mogelijkheid de schroeven te meten!



MONTAGEANLEITUNG Hängeelement 8R 35er Breite

TYP 4491 / 4492

WALL UNIT 8R, 35 CM WIDE
ELEMENT SUSPENDU 8U, 35 CM DE LARGE
HANGELEMENT 8R, 35 CM BREED

now!
by hülsta

no.7

GESAMTÜBERSICHT · SUMMARY · VUE GENERALE · TOTAALOVERZICHT

Für die Montage wird benötigt:

Necessary for assembly:

Pour le montage il faut:

Benodigdheden voor de montage:

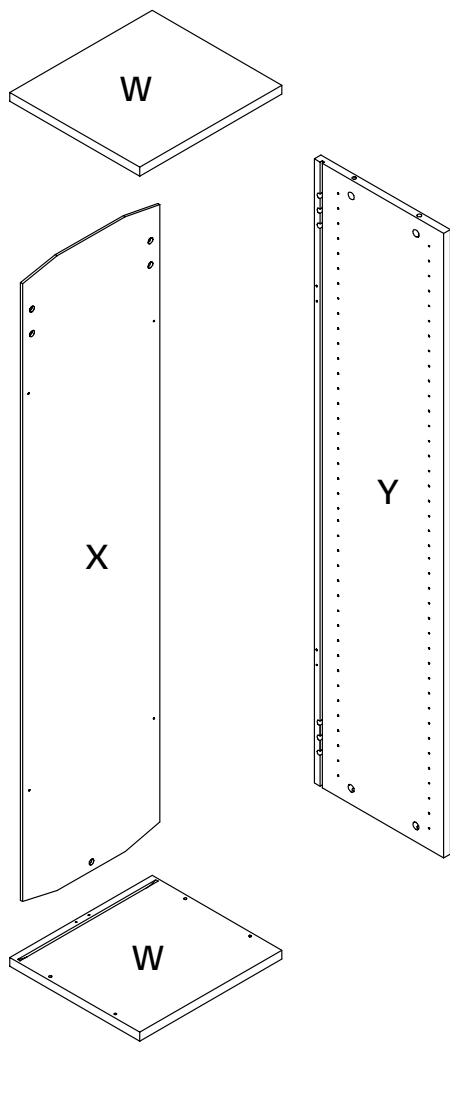
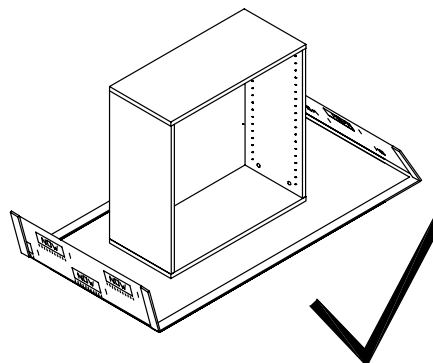
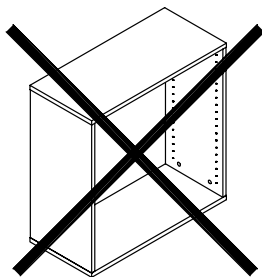
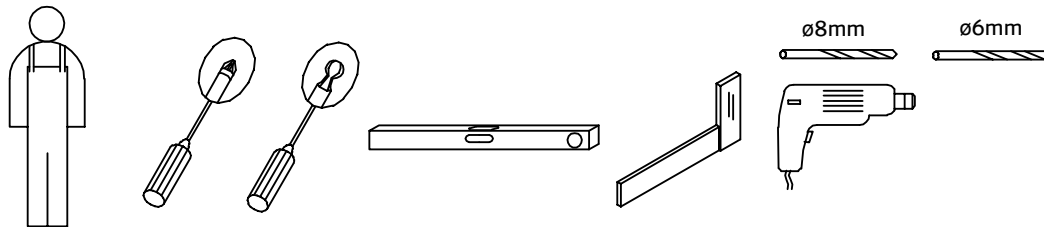

Holztür/ -einlegeboden

Wooden door and wooden shelf

Porte en bois et tablette en bois

Houten deur en houten plank

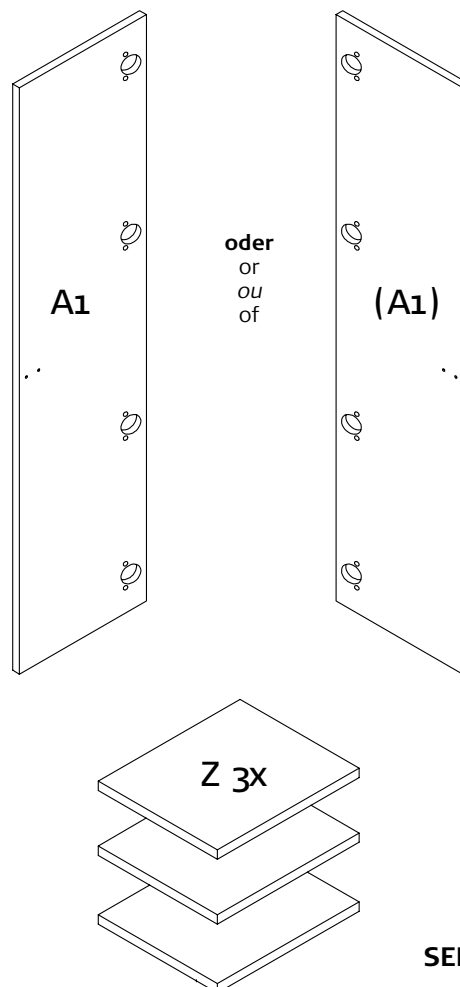

MONTAGEANLEITUNG

Hängeelement 4R / 8R

TYP 4401 / 4402 / 4421 / 4422 / 4331 / 4332 / 4441 / 4442 /
4341L / 4342L / 4351R / 4352R / 4491 / 4492

WALL UNIT 4R / 8R
ELEMENT SUSPENDU 4U / 8U
HANGELEMENT 4R / 8R

now!
by hülsta

no.7

MONTAGE · ASSEMBLY · MONTAGE · MONTAGE

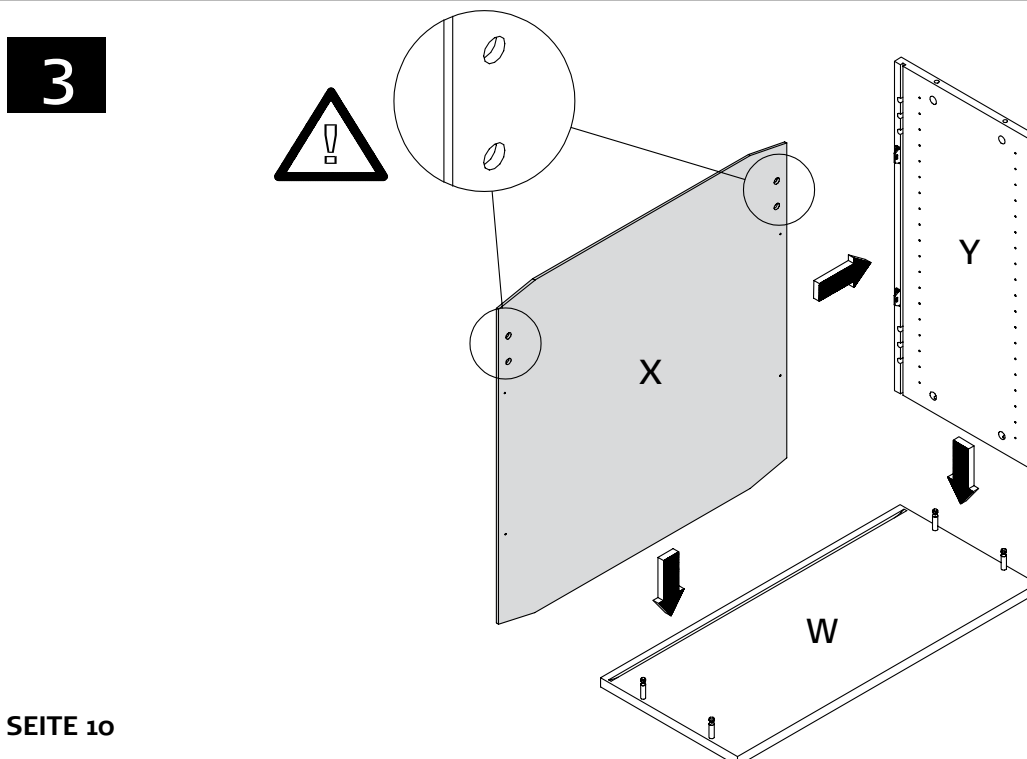
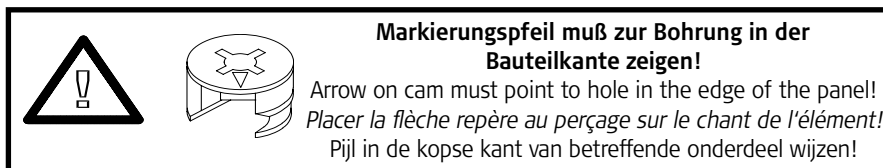
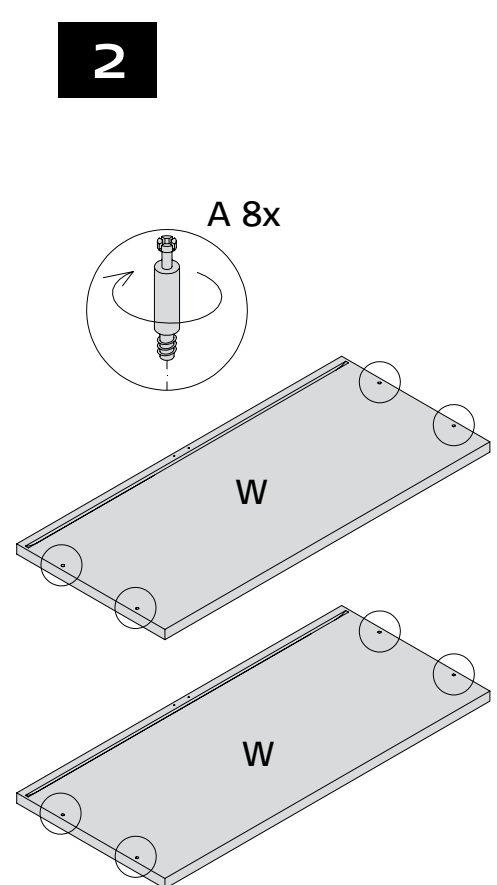
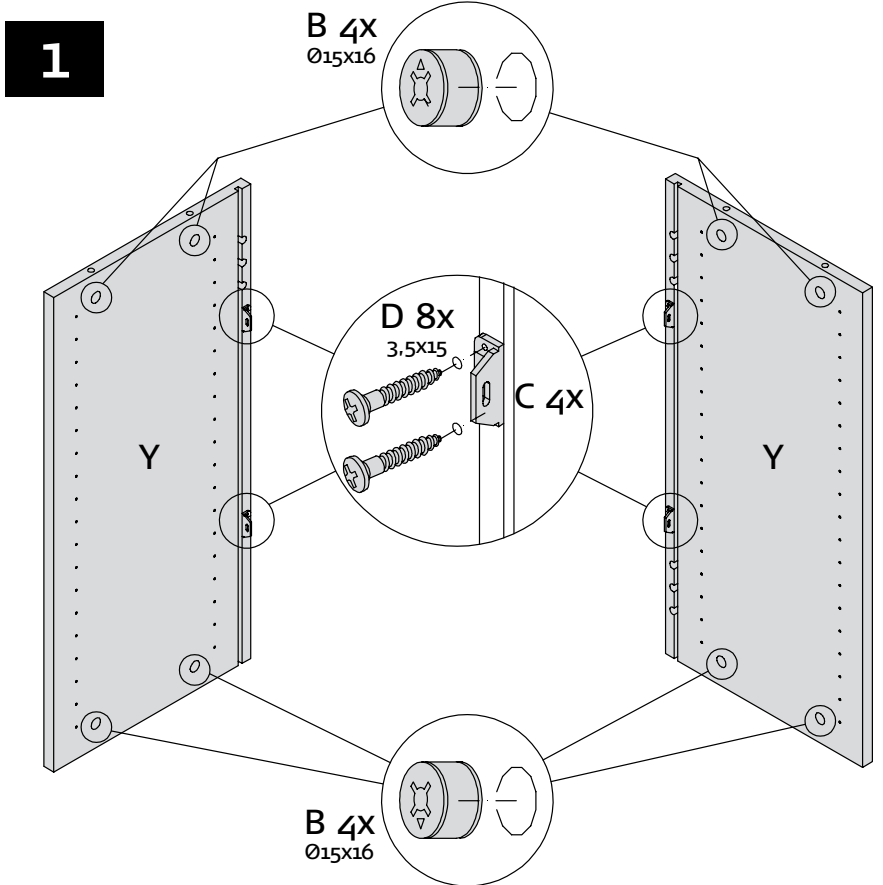

MONTAGEANLEITUNG

Hängeelement 4R / 8R

TYP 4401 / 4402 / 4421 / 4422 / 4331 / 4332 / 4441 / 4442 /
4341L / 4342L / 4351R / 4352R / 4491 / 4492

WALL UNIT 4R / 8R
ELEMENT SUSPENDU 4U / 8U
HANGELEMENT 4R / 8R

now!
by hülsta

no.7

MONTAGE · ASSEMBLY · MONTAGE · MONTAGE

4

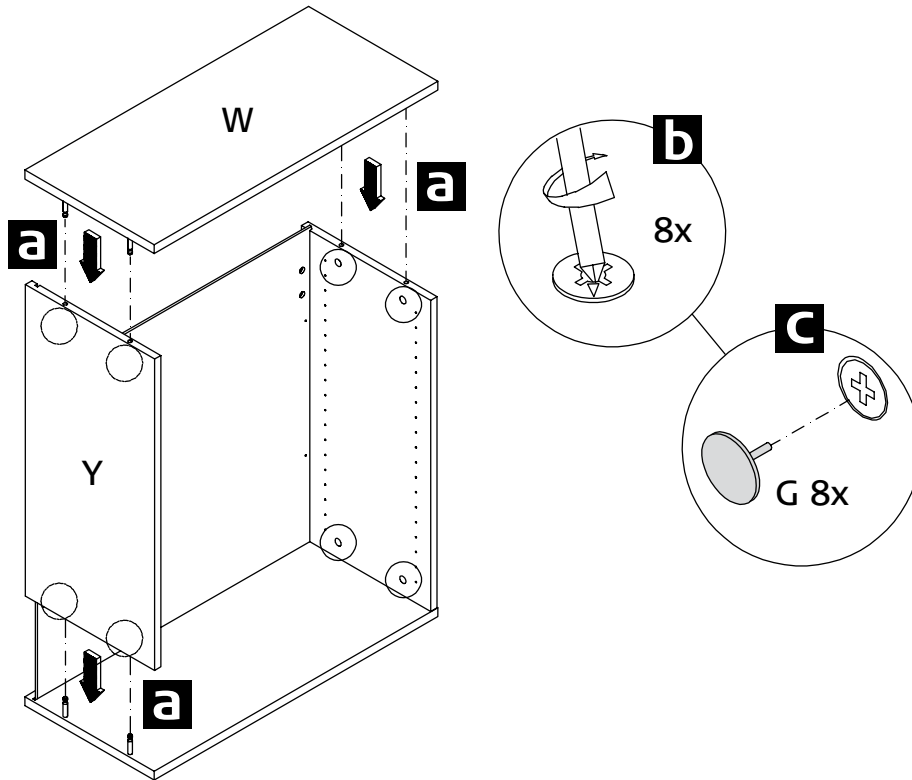

5

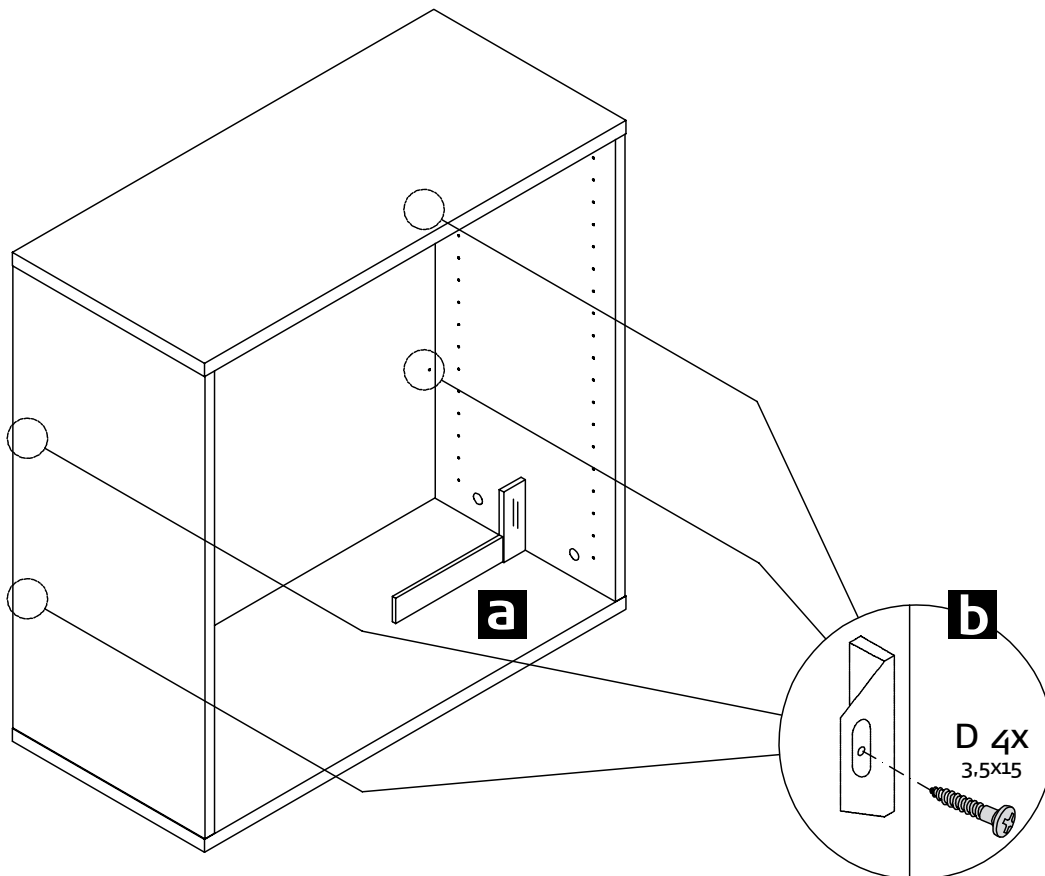

MONTAGEANLEITUNG

Hängeelement 4R / 8R - Holztür / -einlegeboden

TYP 4401 / 4402 / 4421 / 4422 / 4331 /
4332 / 4441 / 4442 / 4491 / 4492

WALL UNIT 4R / 8R - WOODEN DOOR AND WOODEN SHELF
ELEMENT SUSPENDU 4U / 8U - PORTE EN BOIS ET TABLETTE EN BOIS
HANGELEMENT 4R / 8R - HOUTEN DEUR EN HOUTEN PLANK

now!
by hülsta

no.7

MONTAGE · ASSEMBLY · MONTAGE · MONTAGE

6

4R Hängeelement

Typ 4331, 4332, 4441, 4442, 4401, 4402, 4421, 4422
Wall unit 4R

Élément suspendu 4U
Hängeelement 4R

Links
Left
Gauche
Links

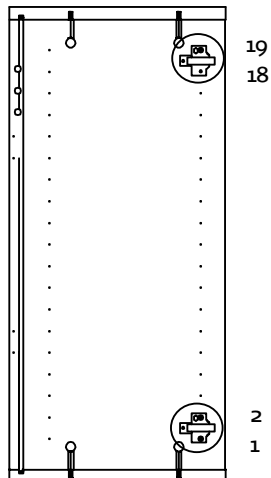
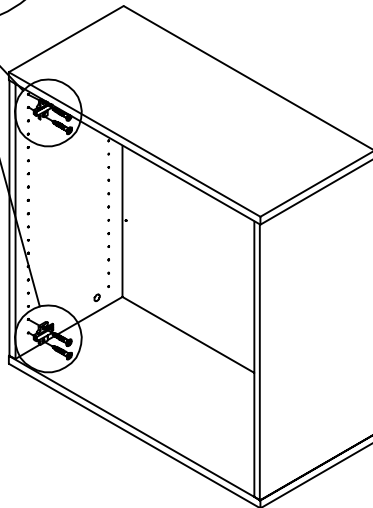
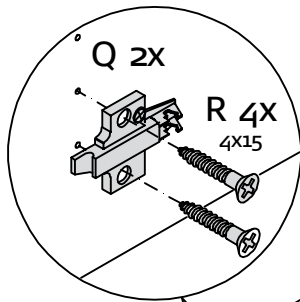
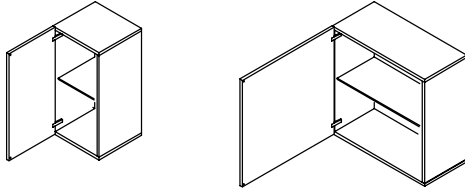

6

4R Hängeelement

Typ 4331, 4332, 4441, 4442, 4401, 4402, 4421, 4422
Wall unit 4R

Élément suspendu 4U
Hängeelement 4R

Rechts
Right
Droite
Rechts

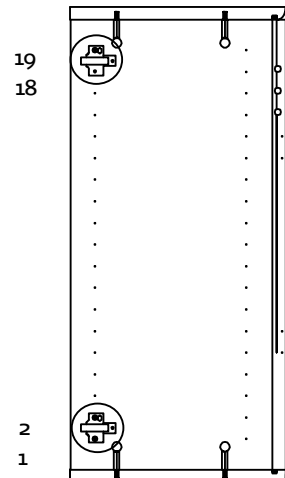
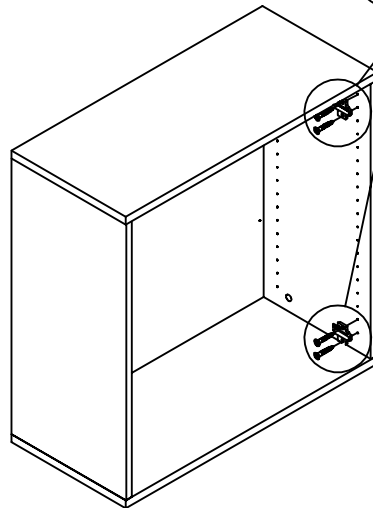
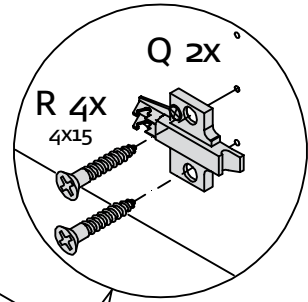
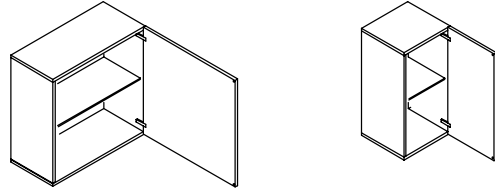

MONTAGEANLEITUNG

Hängeelement 4R / 8R - Holztür / -einlegeboden

TYP 4401 / 4402 / 4421 / 4422 / 4331 /
4332 / 4441 / 4442 / 4491 / 4492

WALL UNIT 4R / 8R - WOODEN DOOR AND WOODEN SHELF
ELEMENT SUSPENDU 4U / 8U - PORTE EN BOIS ET TABLETTE EN BOIS
HANGLEMENT 4R / 8R - HOUTEN DEUR EN HOUTEN PLANK

now!
by hülsta

no.7

MONTAGE · ASSEMBLY · MONTAGE · MONTAGE

6

8R Hängeelement
Typ 4491, 4492
Wall unit 8R
Élément suspendu 8U
Hängelement 8R

Links
Left
Gauche
Links

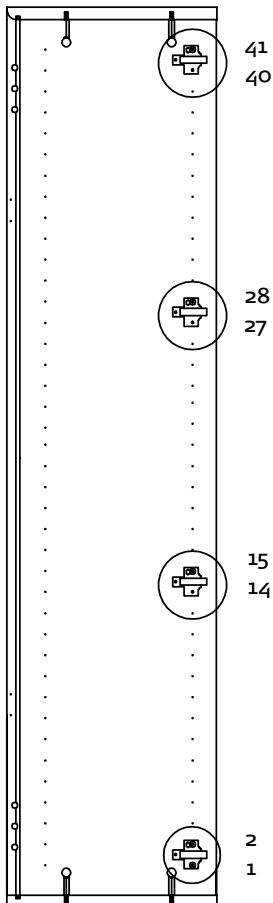
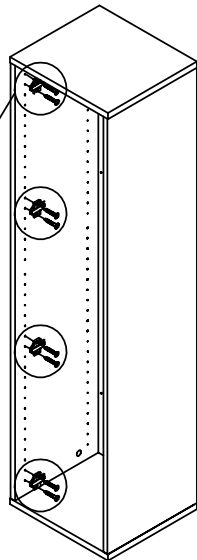
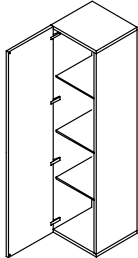

6

8R Hängeelement
Typ 4491, 4492
Wall unit 8R
Élément suspendu 8U
Hängelement 8R

Rechts
Right
Droite
Rechts

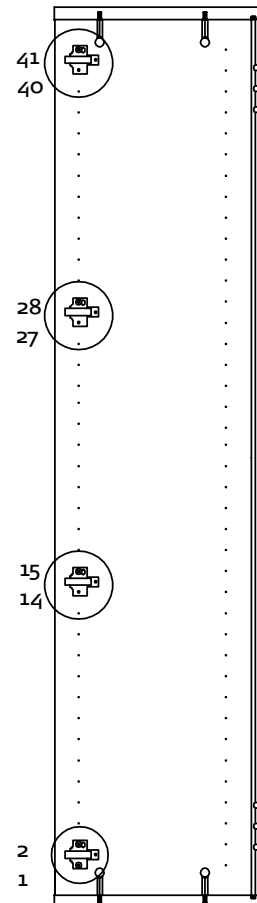
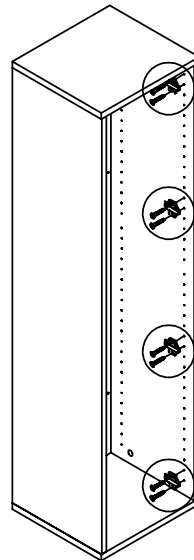
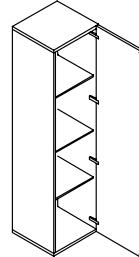

MONTAGEANLEITUNG

Hängeelement 4R / 8R - Holztür / -einlegeboden

TYP 4401 / 4402 / 4421 / 4422 / 4331 /
4332 / 4441 / 4442 / 4491 / 4492

WALL UNIT 4R / 8R - WOODEN DOOR AND WOODEN SHELF
ELEMENT SUSPENDU 4U / 8U - PORTE EN BOIS ET TABLETTE EN BOIS
HANGLEMENT 4R / 8R - HOUTEN DEUR EN HOUTEN PLANK

now!
by hülsta

no.7

MONTAGE · ASSEMBLY · MONTAGE · MONTAGE

7

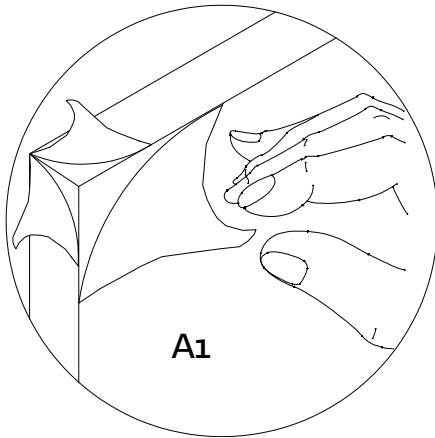

Schutzfolie abziehen!
Remove protective foil!
Enlever feuille de protection!
Beschermingsfolie aftrekken!

8

4R Hängeelement 70er Breite
Typ 4331, 4332, 4441, 4442
Wall unit 4R, 70 cm wide
Élément suspendu 4U, 70 cm de large
Hangelement 4R, 70 cm breed

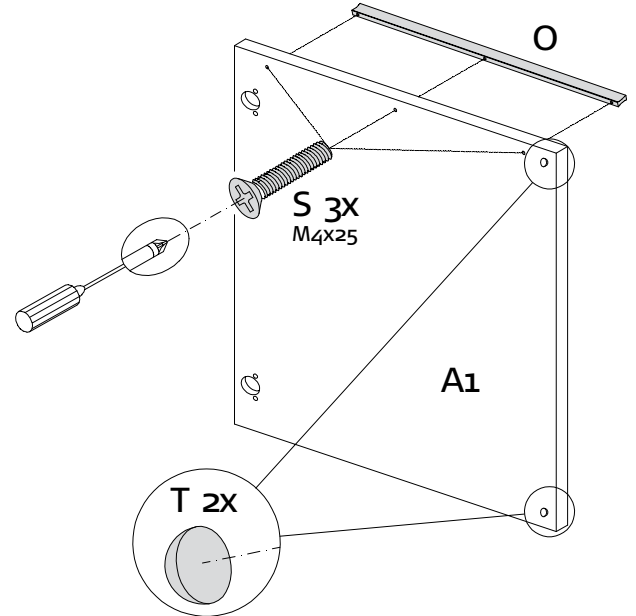

8

4R Hängeelement 35er Breite
Typ 4401, 4402, 4421, 4422
Wall unit 4R, 35 cm wide
Élément suspendu 4U, 35 cm de large
Hangelement 4R, 35 cm breed

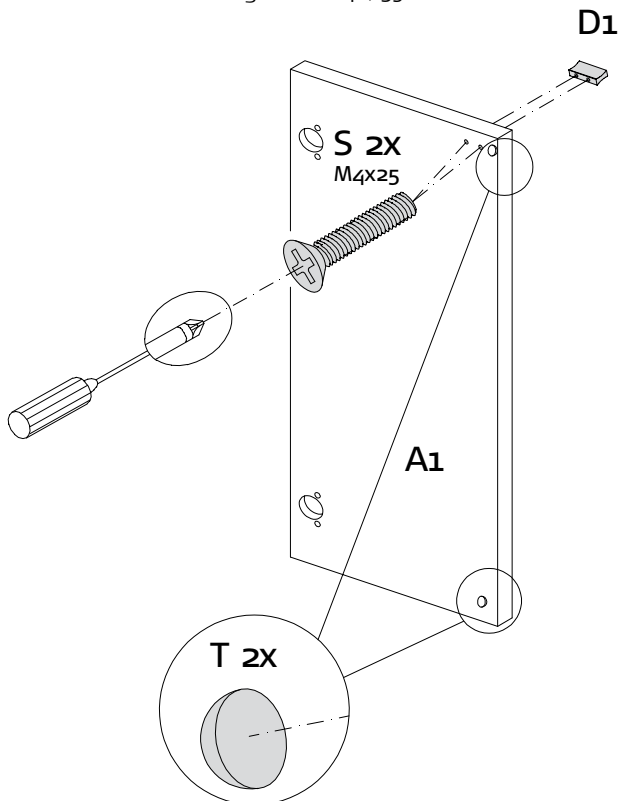

8

8R Hängeelement
Typ 4491, 4492
Wall unit 8R
Élément suspendu 8U
Hangelement 8R

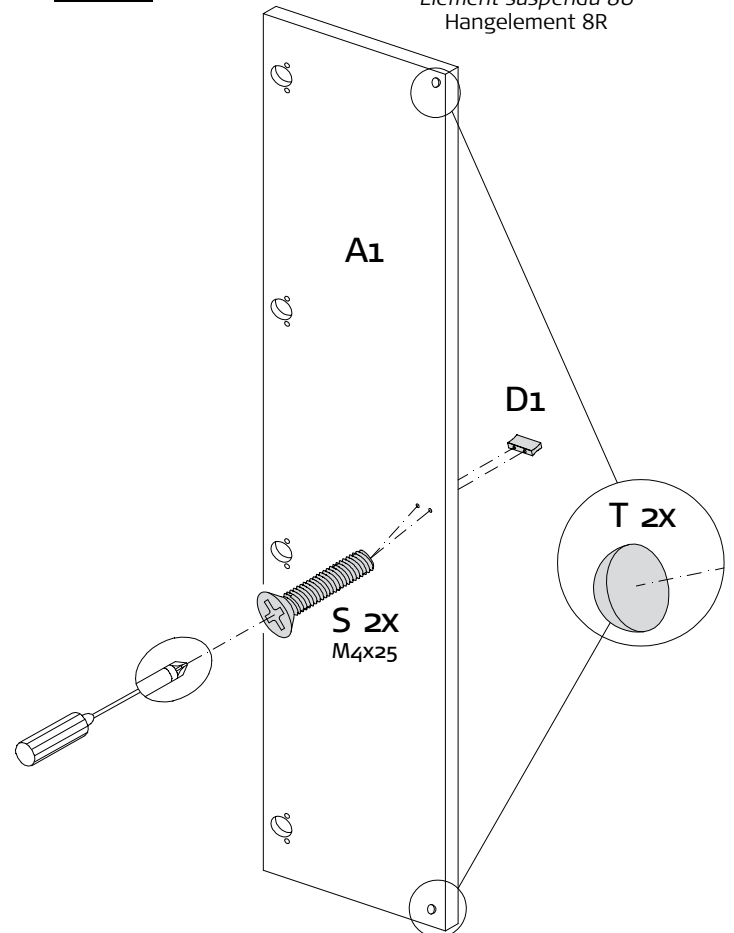

MONTAGEANLEITUNG

Hängeelement 4R / 8R - Holztür / -einlegeboden

Typ 4401 / 4402 / 4421 / 4422 / 4331 /

4332 / 4441 / 4442 / 4491 / 4492

WALL UNIT 4R / 8R - WOODEN DOOR AND WOODEN SHELF
ELEMENT SUSPENDU 4U / 8U - PORTE EN BOIS ET TABLETTE EN BOIS
HANGELEMENT 4R / 8R - HOUTEN DEUR EN HOUTEN PLANK

now!
by hülsta

no.7

MONTAGE · ASSEMBLY · MONTAGE · MONTAGE

9

4R Hängeelement

Typ 4331, 4332, 4441, 4442, 4401, 4402, 4421, 4422

Wall unit 4R

Elément suspendu 4U

Hängeelement 4R

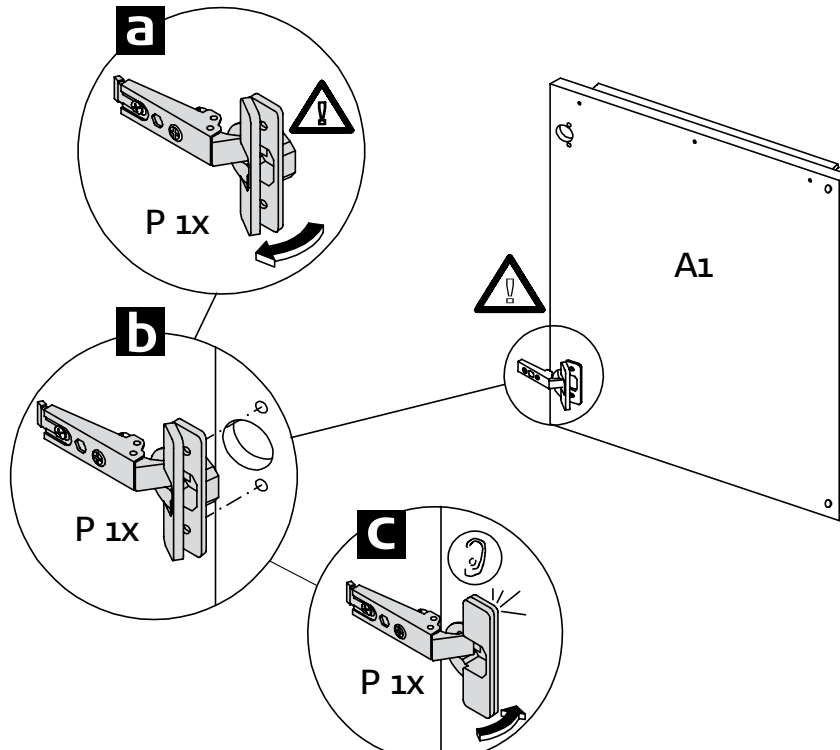

9

8R Hängeelement

Typ 4491, 4492

Wall unit 8R

Elément suspendu 8U

Hängeelement 8R

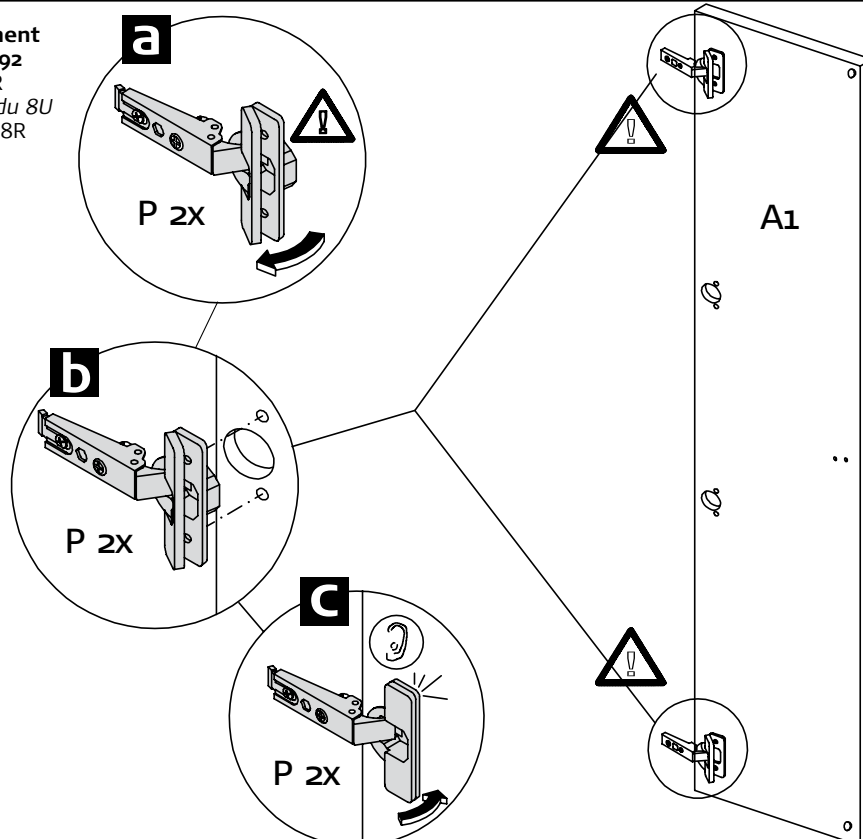

MONTAGEANLEITUNG

Hängeelement 4R / 8R - Holztür / -einlegeboden

TYP 4401 / 4402 / 4421 / 4422 / 4331 /
4332 / 4441 / 4442 / 4491 / 4492

WALL UNIT 4R / 8R - WOODEN DOOR AND WOODEN SHELF
ELEMENT SUSPENDU 4U / 8U - PORTE EN BOIS ET TABLETTE EN BOIS
HANGELEMENT 4R / 8R - HOUTEN DEUR EN HOUTEN PLANK

now!
by hülsta

no.7

MONTAGE · ASSEMBLY · MONTAGE · MONTAGE

10

4R Hängeelement
Typ 4331, 4332, 4441, 4442,
4401, 4402, 4421, 4422
Wall unit 4R
Elément suspendu 4U
Hängeelement 4R

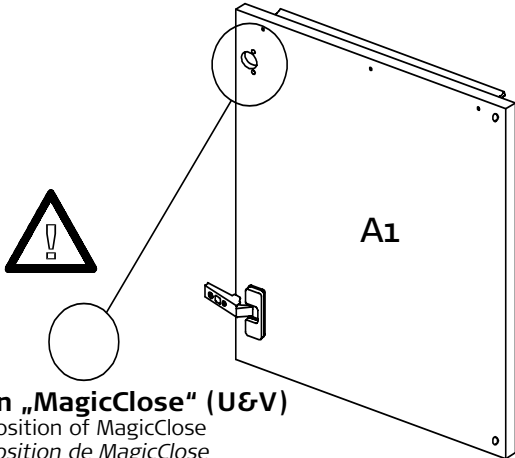

Position „MagicClose“ (U&V)
Position of MagicClose
Position de MagicClose
Positie van MagicClose

10

8R Hängeelement
Typ 4491, 4492
Wall unit 8R
Elément suspendu 8U
Hängeelement 8R

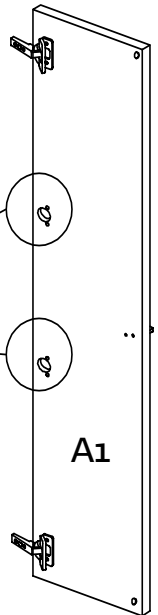

Position MagicClose (U&V)
Position of MagicClose
Position de MagicClose
Positie van MagicClose

11

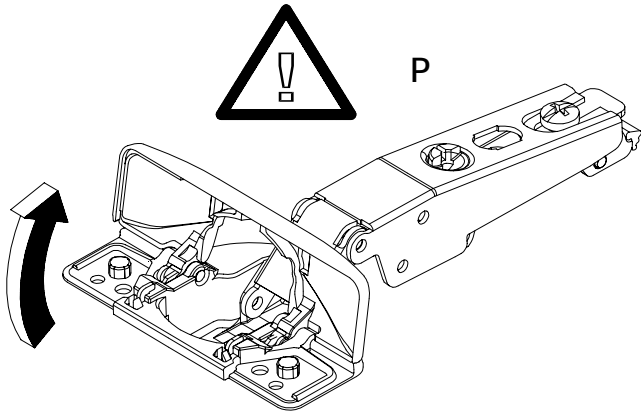

12

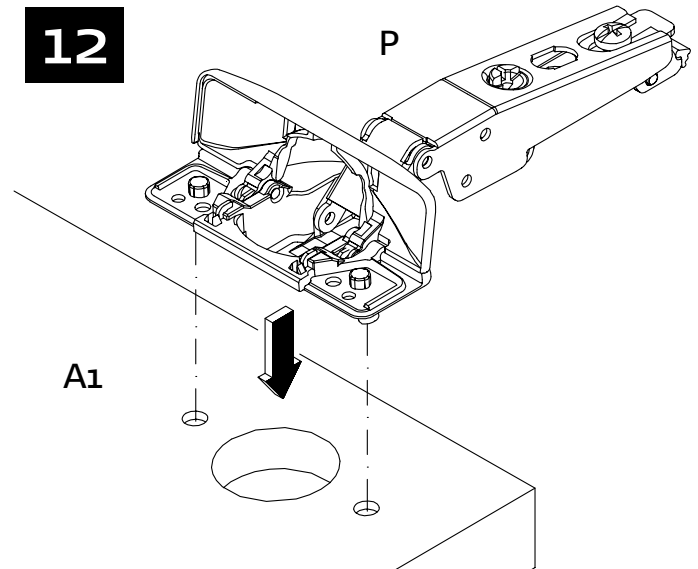

13

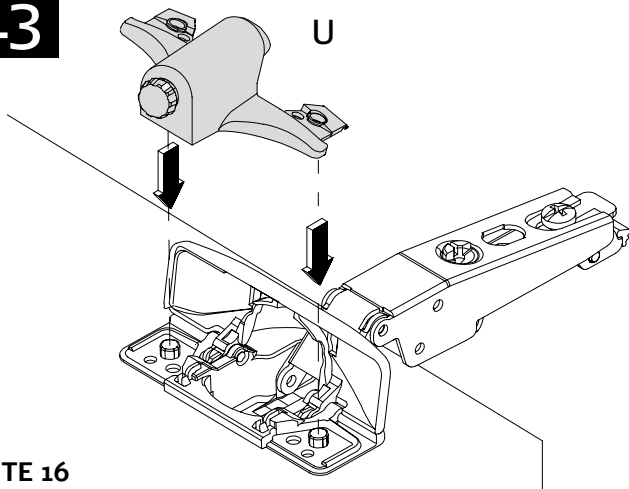

14

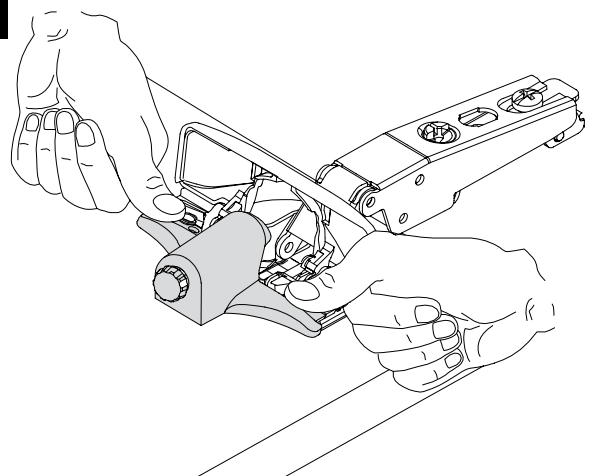

MONTAGEANLEITUNG

Hängeelement 4R / 8R - Holztür / -einlegeboden

TYP 4401 / 4402 / 4421 / 4422 / 4331 /
4332 / 4441 / 4442 / 4491 / 4492

WALL UNIT 4R / 8R - WOODEN DOOR AND WOODEN SHELF
ELEMENT SUSPENDU 4U / 8U - PORTE EN BOIS ET TABLETTE EN BOIS
HANGELEMENT 4R / 8R - HOUTEN DEUR EN HOUTEN PLANK

now!
by hülsta

no.7

MONTAGE · ASSEMBLY · MONTAGE · MONTAGE

15

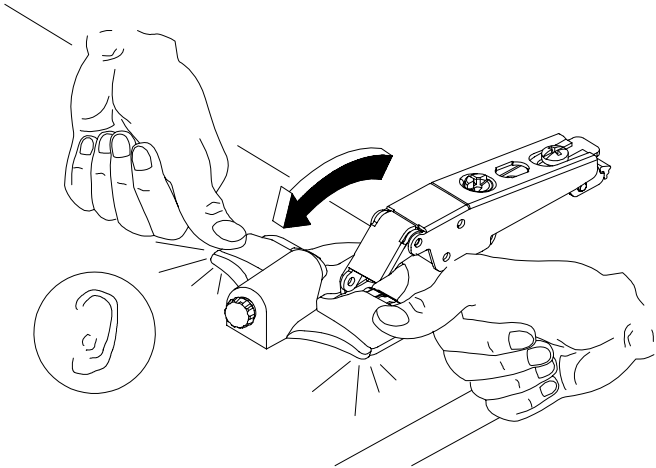

16

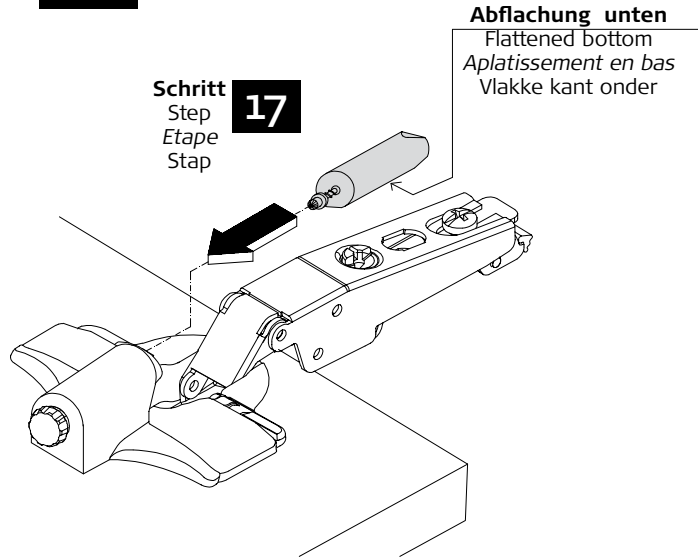

Abflachung unten
Flattened bottom
Aplatissement en bas
Vlakke kant onder

Schritt 17
Step
Etape
Stap

17

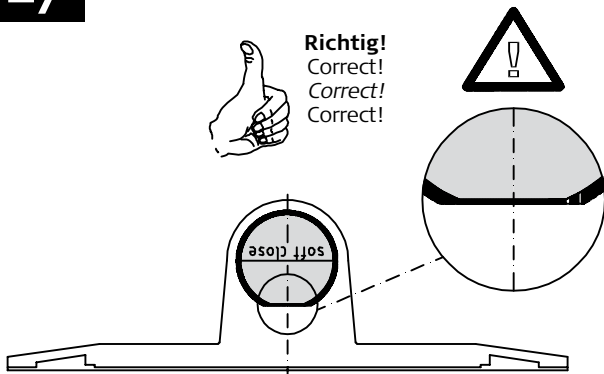

Richtig!
Correct!
Correct!
Correct!

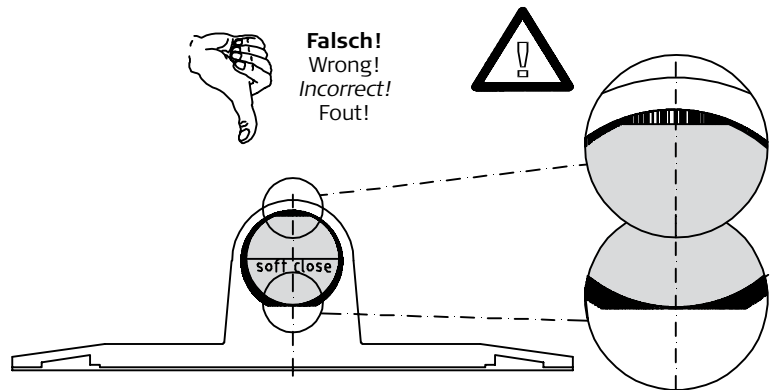

Falsch!
Wrong!
Incorrect!
Fout!

18

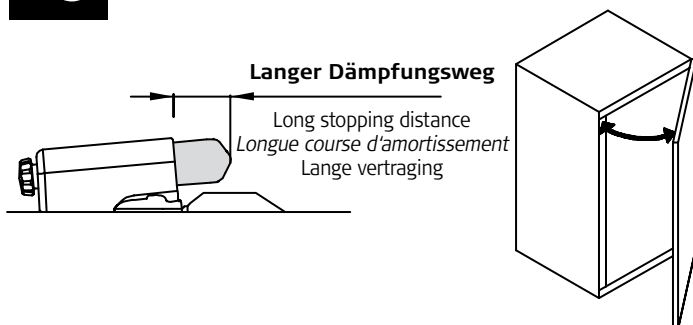

Langer Dämpfungsweg

Long stopping distance
Longue course d'amortissement
Lange vertraging

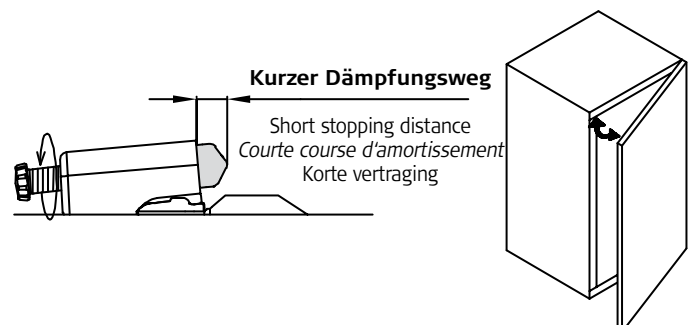

Kurzer Dämpfungsweg

Short stopping distance
Courte course d'amortissement
Korte vertraging

MONTAGEANLEITUNG

Hängeelement 4R / 8R - Holztür / -einlegeboden

TYP 4401 / 4402 / 4421 / 4422 / 4331 /
4332 / 4441 / 4442 / 4491 / 4492

WALL UNIT 4R / 8R - WOODEN DOOR AND WOODEN SHELF
ELEMENT SUSPENDU 4U / 8U - PORTE EN BOIS ET TABLETTE EN BOIS
HANGELEMENT 4R / 8R - HOUTEN DEUR EN HOUTEN PLANK

now!
by hülsta

no.7

MONTAGE · ASSEMBLY · MONTAGE · MONTAGE

19

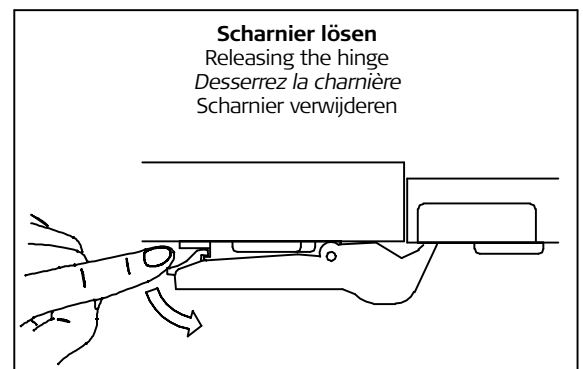
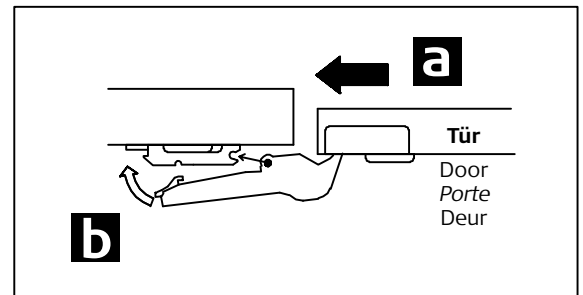
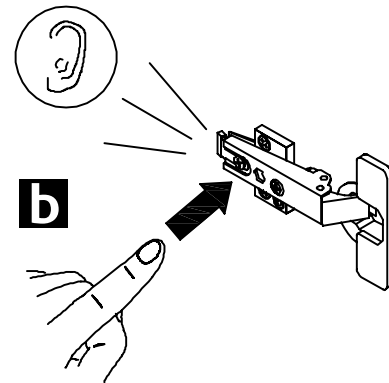
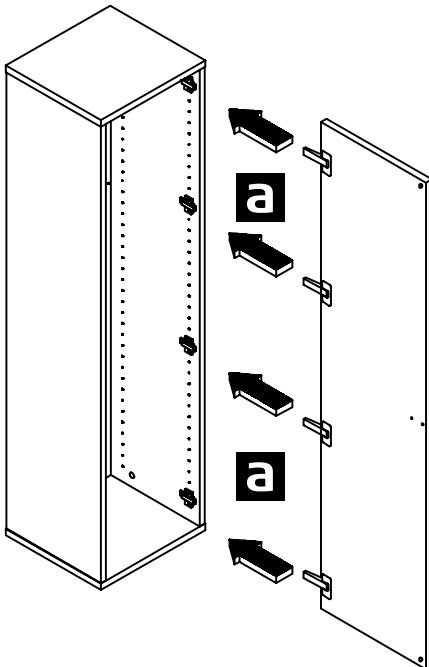
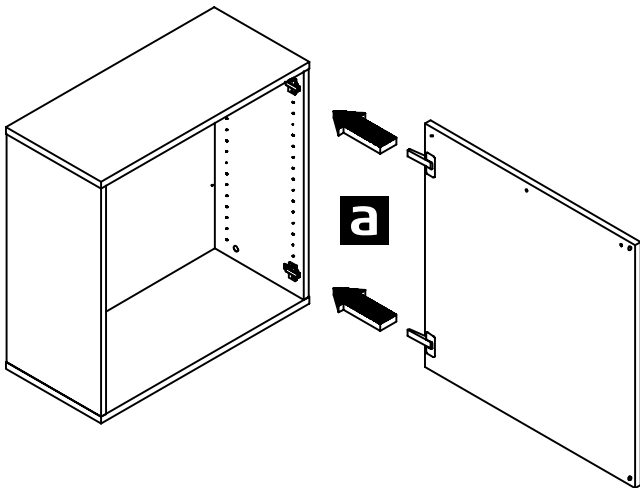

MONTAGEANLEITUNG

Hängeelement 4R / 8R - Holztür / -einlegeboden

TYP 4401 / 4402 / 4421 / 4422 / 4331 /
4332 / 4441 / 4442 / 4491 / 4492

WALL UNIT 4R / 8R - WOODEN DOOR AND WOODEN SHELF
ELEMENT SUSPENDU 4U / 8U - PORTE EN BOIS ET TABLETTE EN BOIS
HANGELEMENT 4R / 8R - HOUTEN DEUR EN HOUTEN PLANK

now!
by hülsta

no.7

MONTAGE · ASSEMBLY · MONTAGE · MONTAGE

20

Scharnierverstellung
Hinge adjustment
Réglage de la charnière
Scharnierverstelling

Holztür
Wooden door
Porte en bois
Houten deur

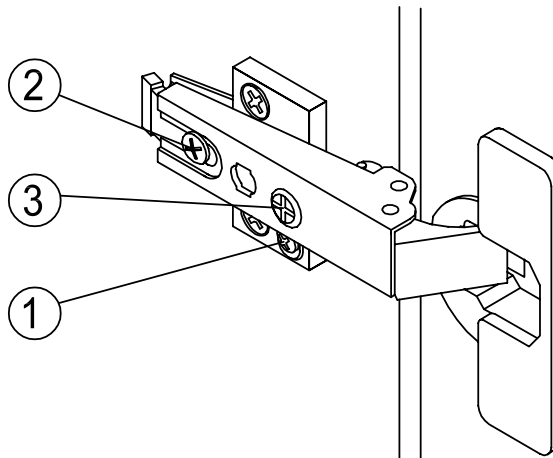
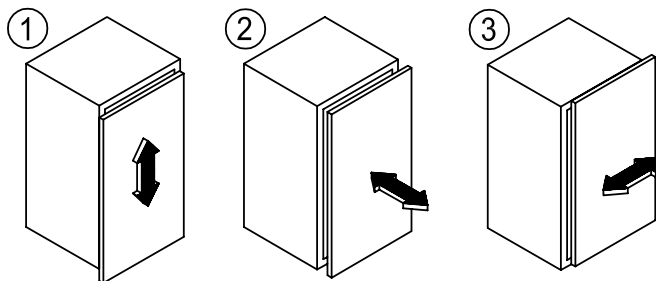

21

4R Hängeelement
Typ 4331, 4332, 4441, 4442,
4401, 4402, 4421, 4422
Wall unit 4R
Elément suspendu 4U
Hängeelement 4R

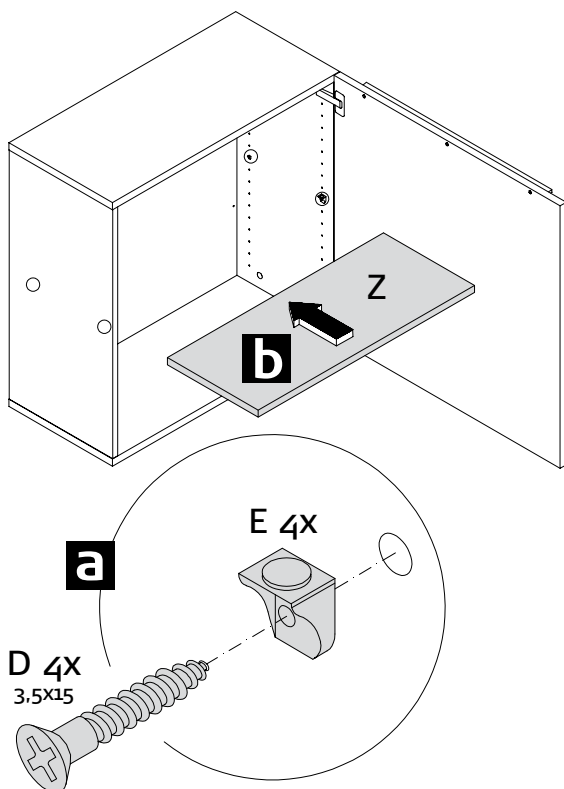

21

8R Hängeelement
Typ 4491, 4492
Wall unit 8R
Elément suspendu 8U
Hängeelement 8R

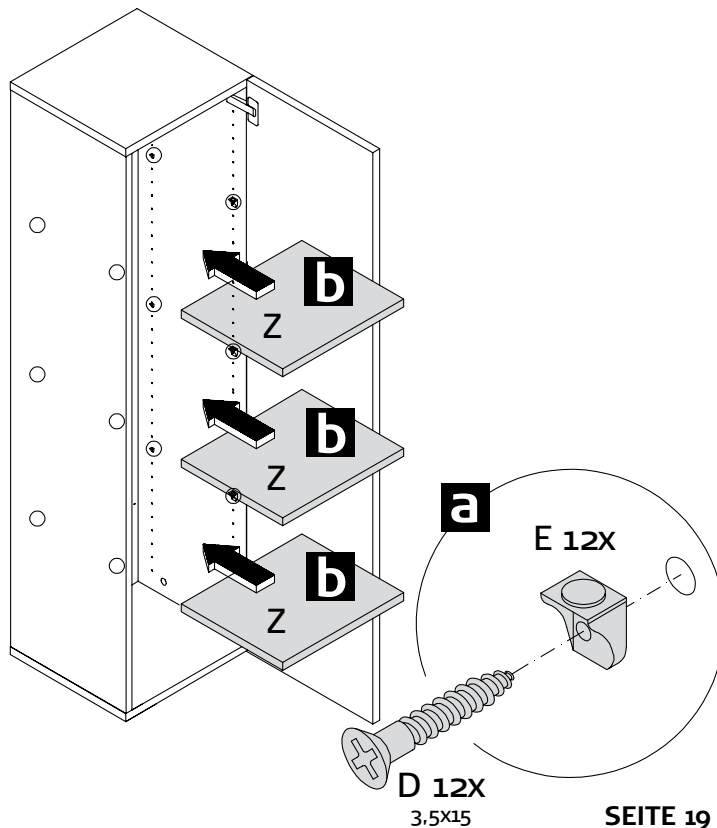

SEITE 19

MONTAGEANLEITUNG

Hängeelement 4R - Glastür / -einlegeboden

TYP 4341L / 4342L / 4351R / 4352R



WALL UNIT 4R - GLASS DOOR AND GLASS SHELF
 ELEMENT SUSPENDU 4U - PORTE EN VERRE ET TABLETTE EN VERRE
 HANGELEMENT 4R - GLASDEUR EN GLAZEN LEGGER

MONTAGE · ASSEMBLY · MONTAGE · MONTAGE

6

Links
 Left
 Gauche
 Links

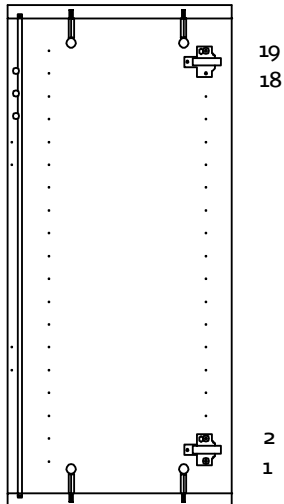
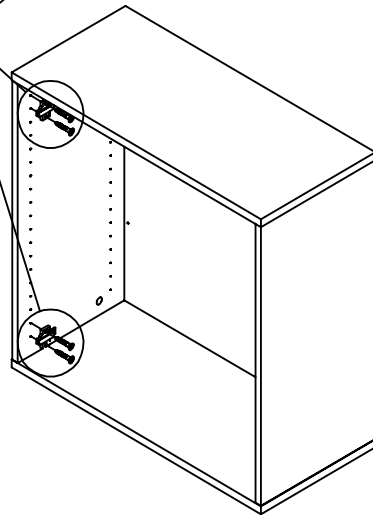
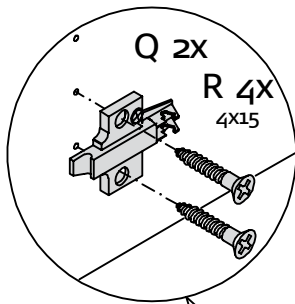
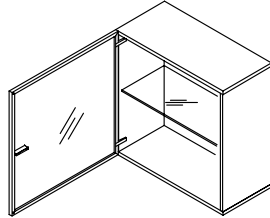

6

Rechts
 Right
 Droite
 Rechts

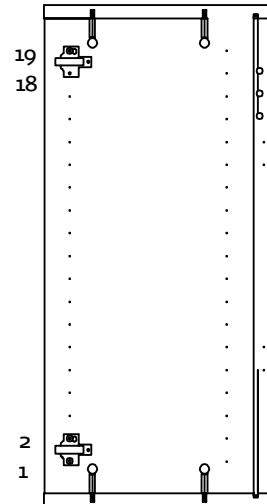
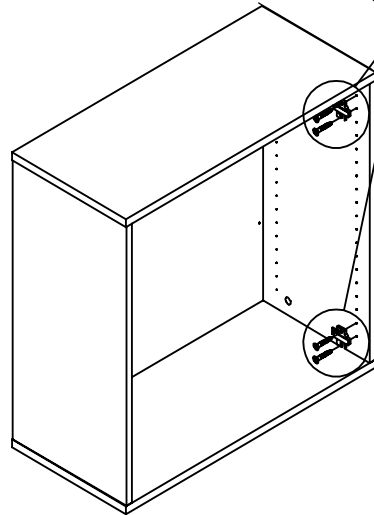
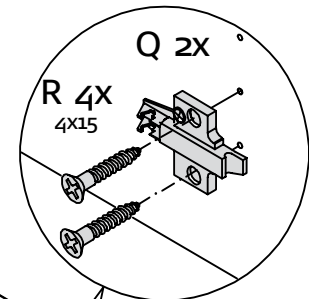
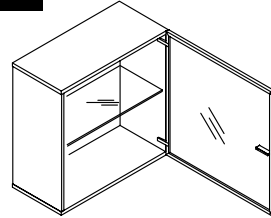

MONTAGEANLEITUNG

Hängeelement 4R - Glastür / -einlegeboden

TYP 4341L / 4342L / 4351R / 4352R

now!
by hülsta

no.7

WALL UNIT 4R - GLASS DOOR AND GLASS SHELF
ELEMENT SUSPENDU 4U - PORTE EN VERRE ET TABLETTE EN VERRE
HANGELEMENT 4R - GLASDEUR EN GLAZEN LEGGER

MONTAGE · ASSEMBLY · MONTAGE · MONTAGE

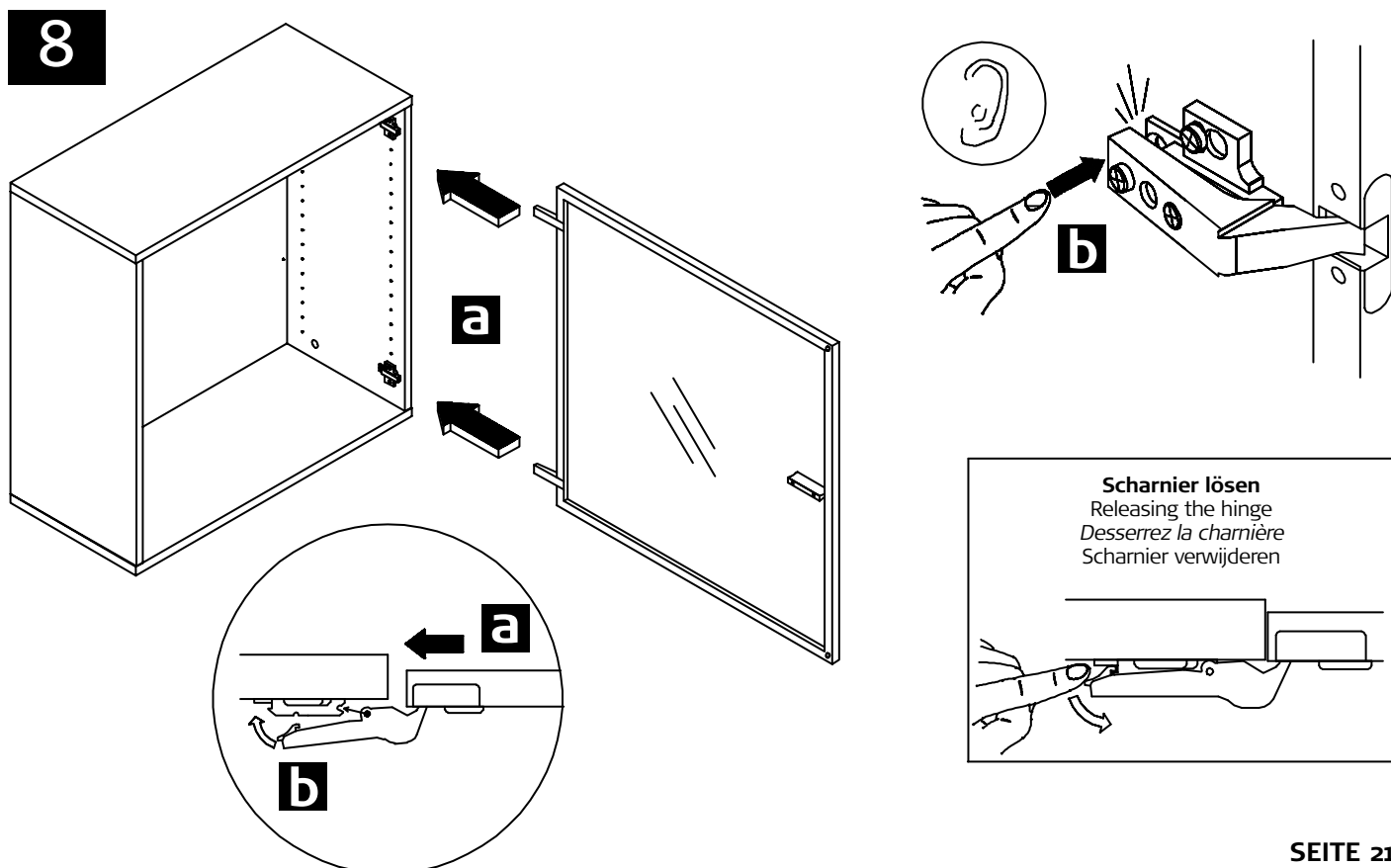
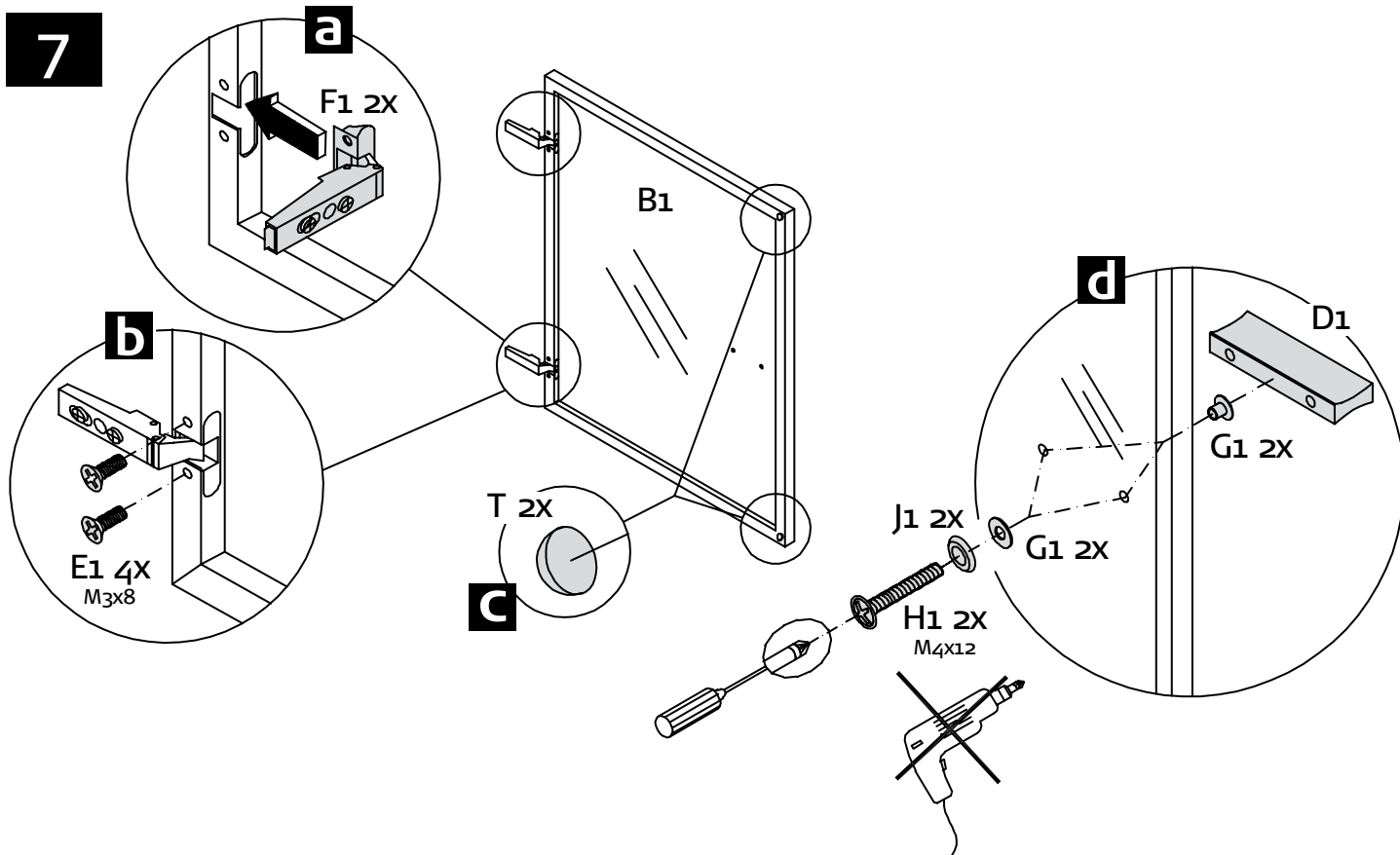

MONTAGEANLEITUNG
Hängeelement 4R - Glastür / -einlegeboden
 TYP 4341L / 4342L / 4351R / 4352R



WALL UNIT 4R - GLASS DOOR AND GLASS SHELF
 ELEMENT SUSPENDU 4U - PORTE EN VERRE ET TABLETTE EN VERRE
 HANGELEMENT 4R - GLASDEUR EN GLAZEN LEGGER

MONTAGE · ASSEMBLY · MONTAGE · MONTAGE

9

Scharnierverstellung
 Hinge adjustment
 Réglage de la charnière
 Scharnierverstellung

Glastür
 Glass door
 Porte en verre
 Glasdeur

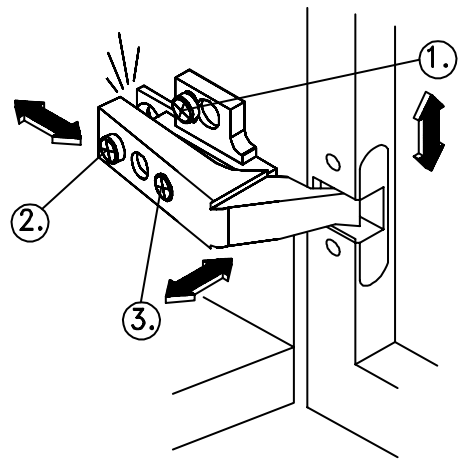
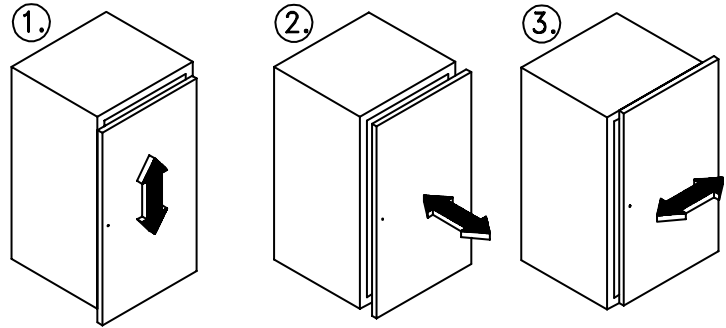

10

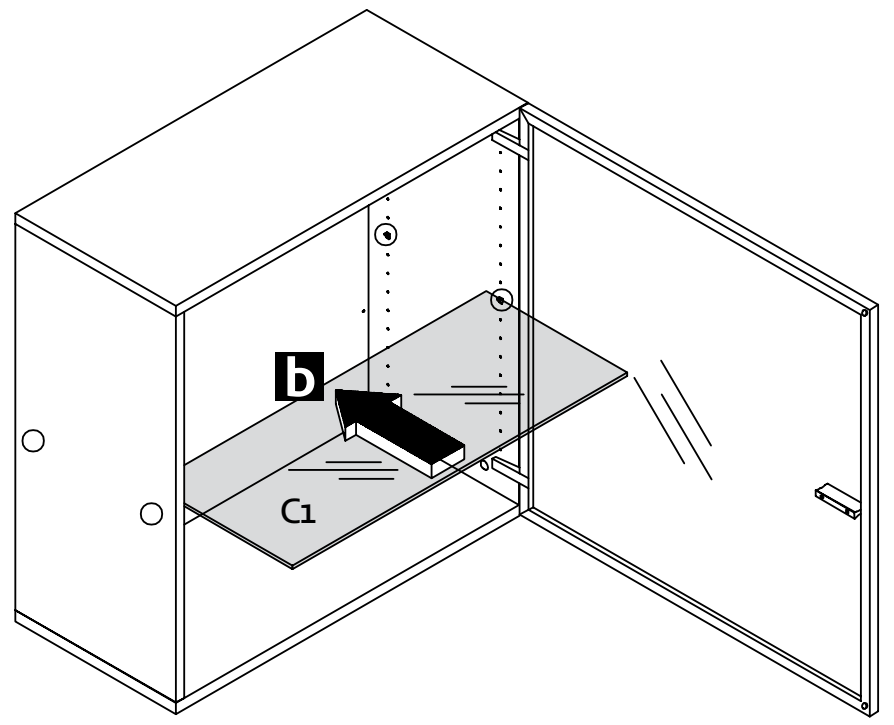
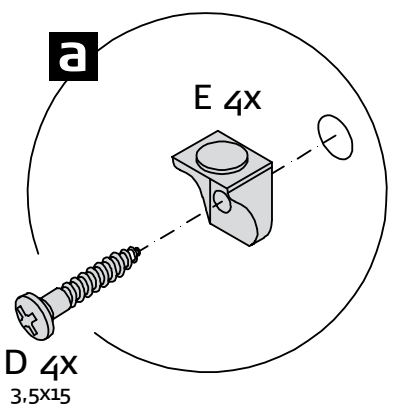

MONTAGEANLEITUNG
Hängeelement 4R / 8R - Aufhängung
 TYP 4401 / 4402 / 4421 / 4422 / 4331 / 4332 / 4441 / 4442 /
 4341L / 4342L / 4351R / 4352R / 4491 / 4492
 WALL UNIT 4R / 8R - WALL ASSEMBLY
 ELEMENT SUSPENDU 4U / 8U - FIXATION MURALE
 HANGELEMENT 4R / 8R - WANDBEVESTIGING

now! by hülsta **no.7**

MONTAGE · ASSEMBLY · MONTAGE · MONTAGE

1

Nur bei Typ:
 Only for type:
Seulement pour réf.:
 Slechts voor type:
4401, 4402, 4421,
4422, 4491, 4492

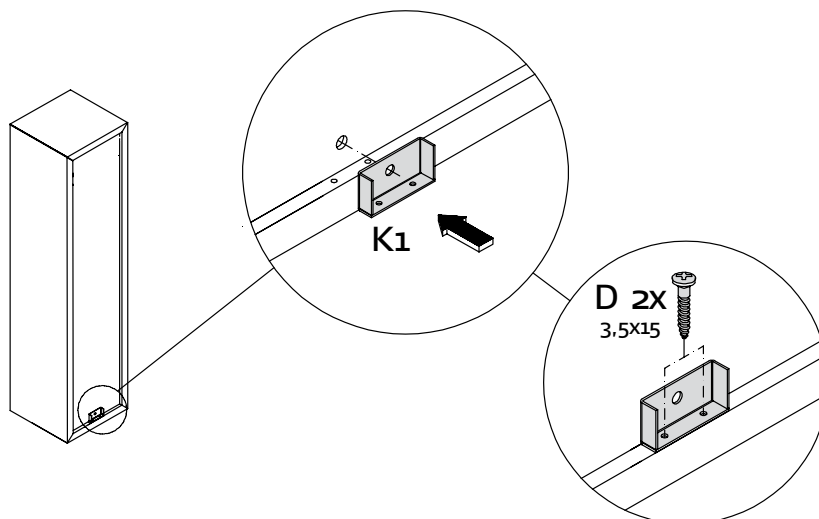

2

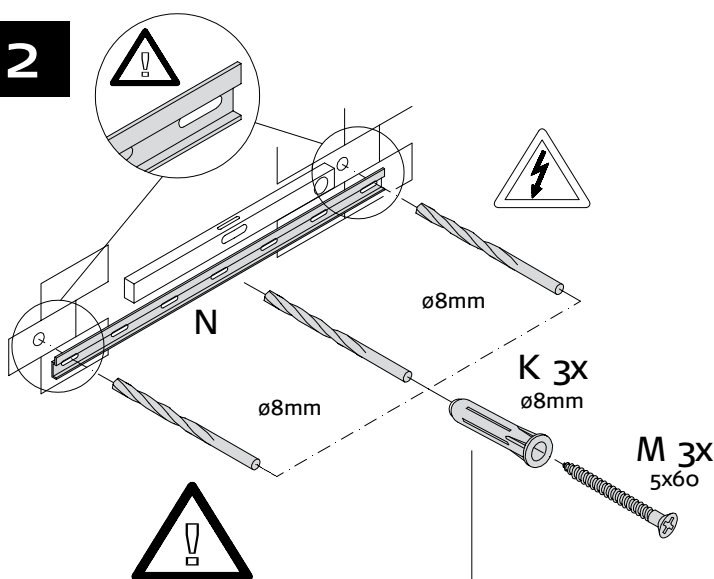

Gefahr bei fehlerhafter Montage!

Danger if not properly fitted!

Danger lors d'un montage incorrect!

Attentie! Een verkeerde montage kan gevaarlijk zijn!

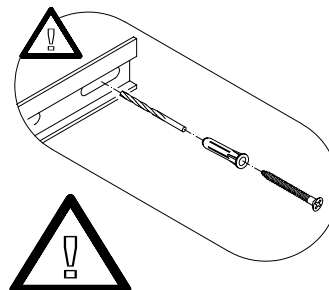

Schiene zwingend an den äußersten Langlöchern befestigen.

Be sure to secure the rail in the oval holes at the ends.

Fixer absolument les rails sur les trous oblongues extérieurs.

Het is absoluut noodzakelijk de buitenste sleufgaten voor de bevestiging van de rail te gebruiken.

Wandbefestigung

Achtung! Die Wandbeschaffenheit ist vor der Montage unbedingt zu prüfen. Verwendung von Dübeln bei Beton und/oder festem Mauerwerk. Bei abweichender Beschaffenheit (z.B. Rahmenbauweise mit Gipskartonplatten, Leichtbausteinen etc.) ist eine andere, der Belastung angemessene Befestigung bauseits vorzunehmen. Beachten Sie, dass in dem Befestigungsbereich keine Elektro-Installationszonen und keine Ver- oder Entsorgungsleitungen vorhanden sein dürfen. Prüfen Sie mit einem geeigneten Leitungssuchgerät. Beachten Sie, dass Kunststoffrohre nicht dedektiert werden.

Wall mounting

Please note! Please be sure to test the soundness of walls beforehand. Use plugs for concrete and solid walls. Use a different method that is capable of withstanding the load for lighter types of walls (e.g. framed gypsum plaster board, light brickwork, etc.). Please note that there must not be any electrical installations nor any electrical connections or leads of any kind in the assembly area. Please ensure this is so by testing the area with a suitable electrical leads search device. Please also note that plastic tubing will not be detected.

Fixation murale

Attention! La composition du mur doit absolument être contrôlée. Utilisation de chevilles pour le béton et/ou la maçonnerie dure. Pour les autres types de construction (cloisons en placoplâtre, maçonnerie légère, etc...), il faut prévoir un autre mode de fixation en rapport avec la charge. Veuillez contrôler l'absence d'installations électriques et de conduits dans le secteur de la fixation à l'aide d'un appareil. Veuillez noter que les tubes en matière synthétique ne sont pas détectés.

Bevestiging aan de muur

Attentie! Controleer, alvorens te beginnen, altijd de aard en de kwaliteit van de muur, waaraan gemonteerd moet worden. Gebruik voor de bevestiging aan beton en schoon metselwerk de door hülsta meegeleverde standaard pluggen en passende schroeven. In geval van muren van een ander, lichter soort materiaal (bijv. gipsplaten op een raamwerk of lichte bouwstenen) moet een ander, aan het draagvermogen aangepast speciaal bevestigingsmateriaal gebruikt worden. N.B.! In het muurgedeelte waar gemonteerd moet worden, mogen zich geen elektro-installatiezones bevinden resp. mogen geen aan- en/of afvoerleidingen (buizen) lopen. Dit kan gecontroleerd worden met speciale daarvoor bestemde detectieapparatuur. N.B.! Kunststoffleidingen kunnen helaas niet worden gedetecteerd.

MONTAGEANLEITUNG Hängeelement 4R / 8R - Aufhängung

TYP 4401 / 4402 / 4421 / 4422 / 4331 / 4332 / 4441 / 4442 /
4341L / 4342L / 4351R / 4352R / 4491 / 4492

WALL UNIT 4R / 8R - WALL ASSEMBLY
ELEMENT SUSPENDU 4U / 8U - FIXATION MURALE
HANGELEMENT 4R / 8R - WANDBEVESTIGUNG

now!
by hülsta

no.7

MONTAGE · ASSEMBLY · MONTAGE · MONTAGE

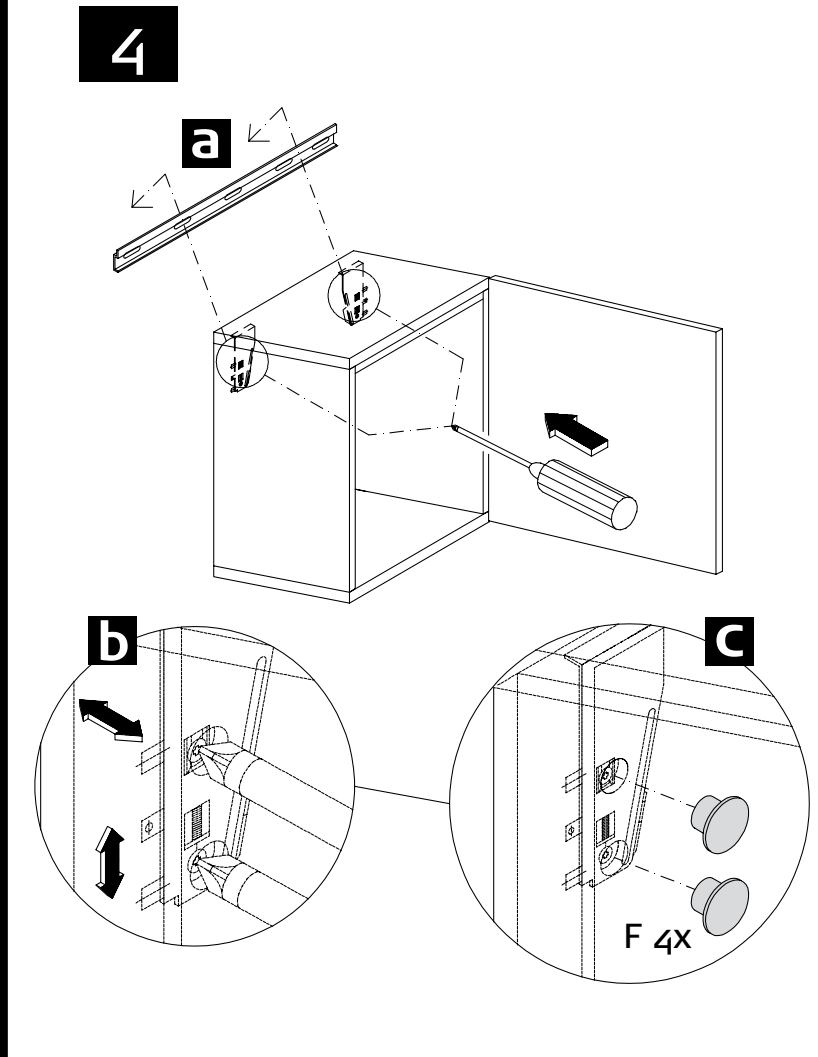
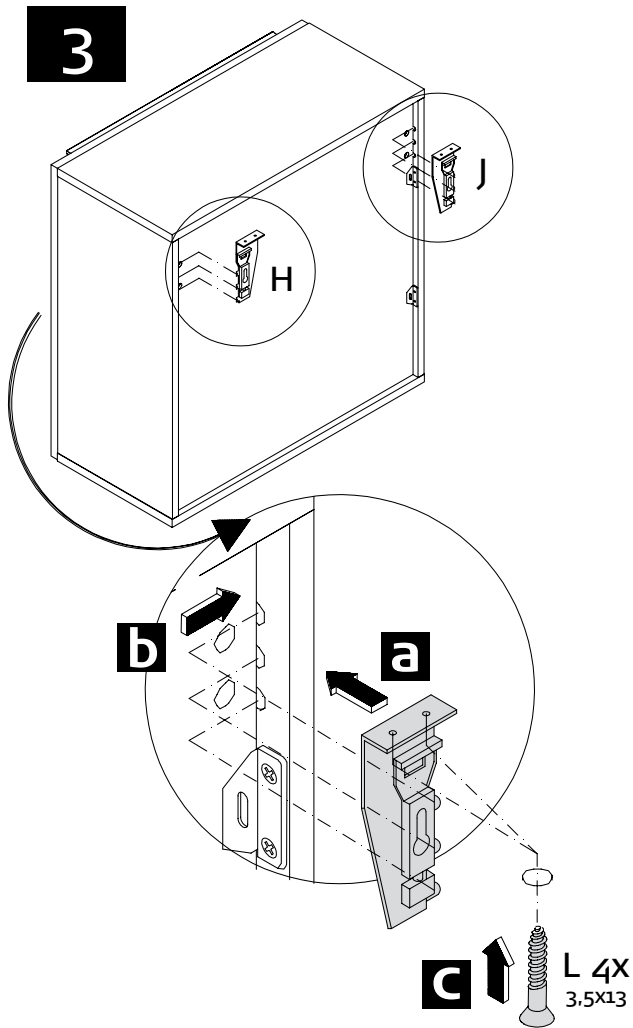

5

Nur bei Typ:
Only for type:
Seulement pour réf.:
Slechts voor type:
4401, 4402, 4421,
4422, 4491, 4492

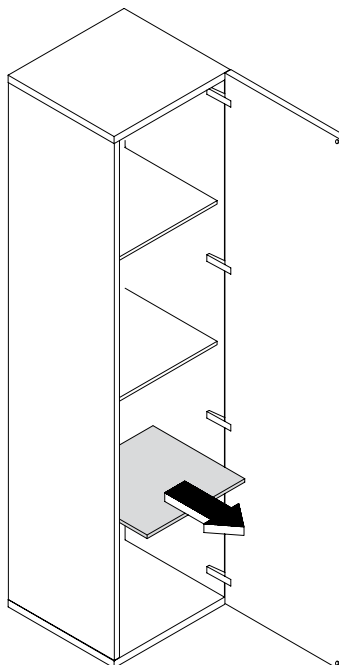

MONTAGEANLEITUNG

Hängeelement 4R / 8R - Aufhängung

TYP 4401 / 4402 / 4421 / 4422 / 4331 / 4332 / 4441 / 4442 /
4341L / 4342L / 4351R / 4352R / 4491 / 4492

WALL UNIT 4R / 8R - WALL ASSEMBLY
ELEMENT SUSPENDU 4U / 8U - FIXATION MURALE
HANGELEMENT 4R / 8R - WANDBEVESTIGING

now!
by hülsta

no.7

MONTAGE · ASSEMBLY · MONTAGE · MONTAGE

6

Nur bei Typ:
Only for type:
Seulement pour réf.:
Slechts voor type:
**4401, 4402, 4421,
4422, 4491, 4492**

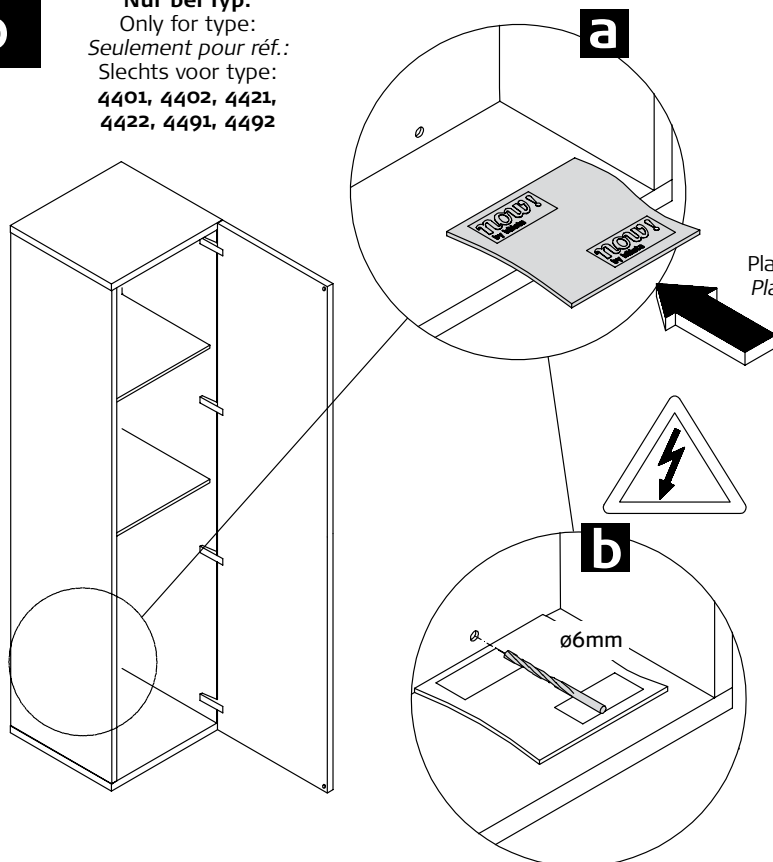

Pappe unterlegen!
Place cardboard underneath!
Placer le carton au-dessous!
Leg karton eronder!

Wandbefestigung

Achtung! Die Wandbeschaffenheit ist vor der Montage unbedingt zu prüfen. Verwendung von Dübeln bei Beton und/oder festem Mauerwerk. Bei abweichender Beschaffenheit (z.B. Rahmenbauweise mit Gipskartonplatten, Leichtbausteinen etc.) ist eine andere, der Belastung angemessene Befestigung bauseits vorzunehmen. Beachten Sie, dass in dem Befestigungsbereich keine Elektro-Installationszonen und keine Ver- oder Entsorgungsleitungen vorhanden sein dürfen. Prüfen Sie mit einem geeigneten Leitungssuchgerät. Beachten Sie, dass Kunststoffrohre nicht dedektiert werden.

Wall mounting

Please note! Please be sure to test the soundness of walls beforehand. Use plugs for concrete and solid walls. Use a different method that is capable of withstanding the load for lighter types of walls (e.g. framed gypsum plaster board, light brickwork, etc.). Please note that there must not be any electrical installations nor any electrical connections or leads of any kind in the assembly area. Please ensure this is so by testing the area with a suitable electrical leads search device. Please also note that plastic tubing will not be detected.

Fixation murale

Attention! La composition du mur doit absolument être contrôlée. Utilisation de chevilles pour le béton et/ou la maçonnerie dure. Pour les autres types de construction (cloisons en placoplâtre, maçonnerie légère, etc...), il faut prévoir un autre mode de fixation en rapport avec la charge. Veuillez contrôler l'absence d'installations électriques et de conduits dans le secteur de la fixation à l'aide d'un appareil. Veuillez noter que les tubes en matière synthétique ne sont pas détectés.

Bevestiging aan de muur

Attentie! Controleer, alvorens te beginnen, altijd de aard en de kwaliteit van de muur, waaraan gemonteerd moet worden. Gebruik voor de bevestiging aan beton en schoon metselwerk de door hülsta meegeleverde standaard pluggen en passende schroeven. In geval van muren van een ander, lichter soort materiaal (bijv. gipsplaten op een raamwerk of lichte bouwstenen) moet een ander, aan het draagvermogen aangepast speciaal bevestigingsmateriaal gebruikt worden. N.B.! In het muurgedeelte waar gemonteerd moet worden, mogen zich geen elektro-installatiezones bevinden resp. mogen geen aan- en/of afvoerleidingen (buisen) lopen. Dit kan gecontroleerd worden met speciale daarvoor bestemde detectieapparatuur. N.B.! Kunststoffleidingen kunnen helaas niet worden gedetecteerd.

7

Nur bei Typ:
Only for type:
Seulement pour réf.:
Slechts voor type:
**4401, 4402, 4421,
4422, 4491, 4492**

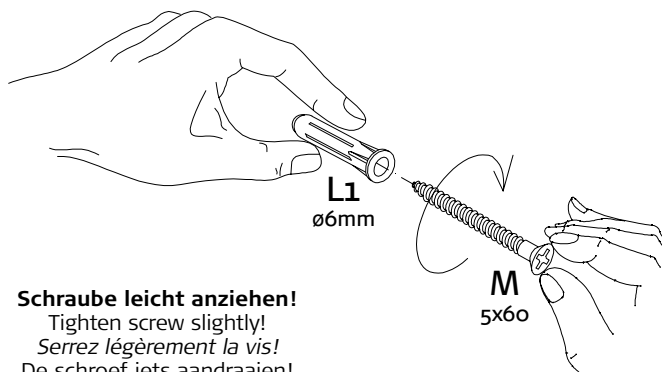

Schraube leicht anziehen!
Tighten screw slightly!
Serrez légèrement la vis!
De schroef iets aandraaien!

MONTAGEANLEITUNG

Hängeelement 4R / 8R - Aufhängung

TYP 4401 / 4402 / 4421 / 4422 / 4331 / 4332 / 4441 / 4442 /
4341L / 4342L / 4351R / 4352R / 4491 / 4492

WALL UNIT 4R / 8R - WALL ASSEMBLY
ELEMENT SUSPENDU 4U / 8U - FIXATION MURALE
HANGELEMENT 4R / 8R - WANDBEVESTIGING

now!
by hülsta

no.7

MONTAGE · ASSEMBLY · MONTAGE · MONTAGE

8

Nur bei Typ:
Only for type:
Seulement pour réf.:
Slechts voor type:
4401, 4402, 4421,
4422, 4491, 4492

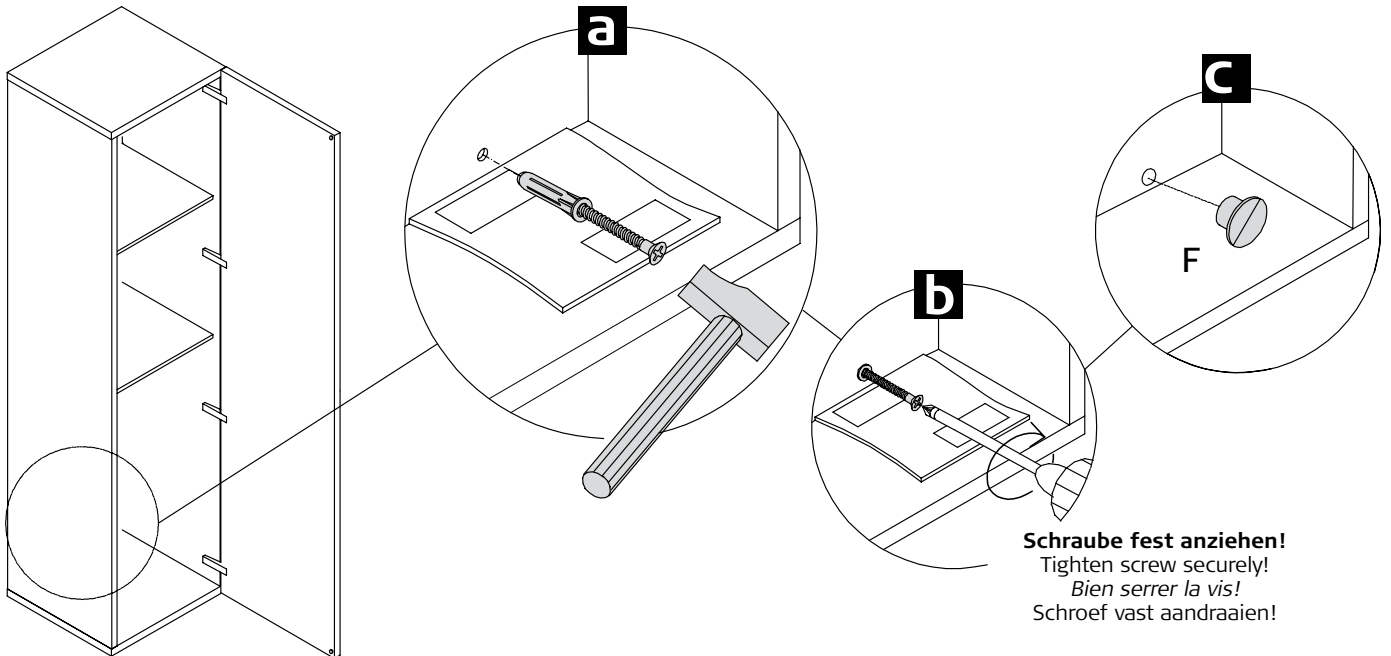

9

Nur bei Typ:
Only for type:
Seulement pour réf.:
Slechts voor type:
4401, 4402, 4421,
4422, 4491, 4492

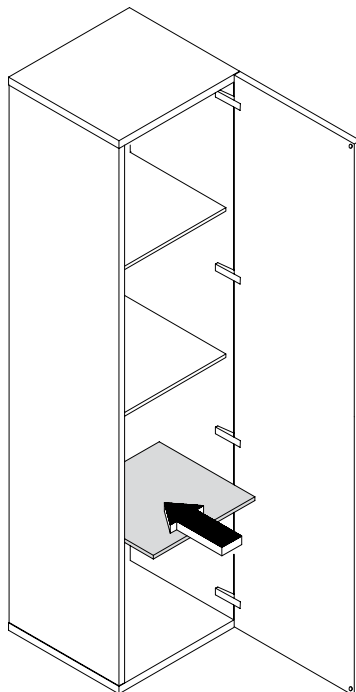

SERVICE