



MONTAGEANLEITUNG HÄNGEELEMENT 2R

TYP 4371 / 4372 / 4301 / 4302 / 4381 /
4382 / 4391 / 4392 / 4481 / 4482

WALL UNIT 2R
ELEMENT SUSPENDU 2U
HÄNGEELEMENT 2R

now! no.7
by hülsta

MONTAGEANLEITUNG · ASSEMBLY INSTRUCTION · NOTICE DE MONTAGE · MONTAGEHANDLEIDING

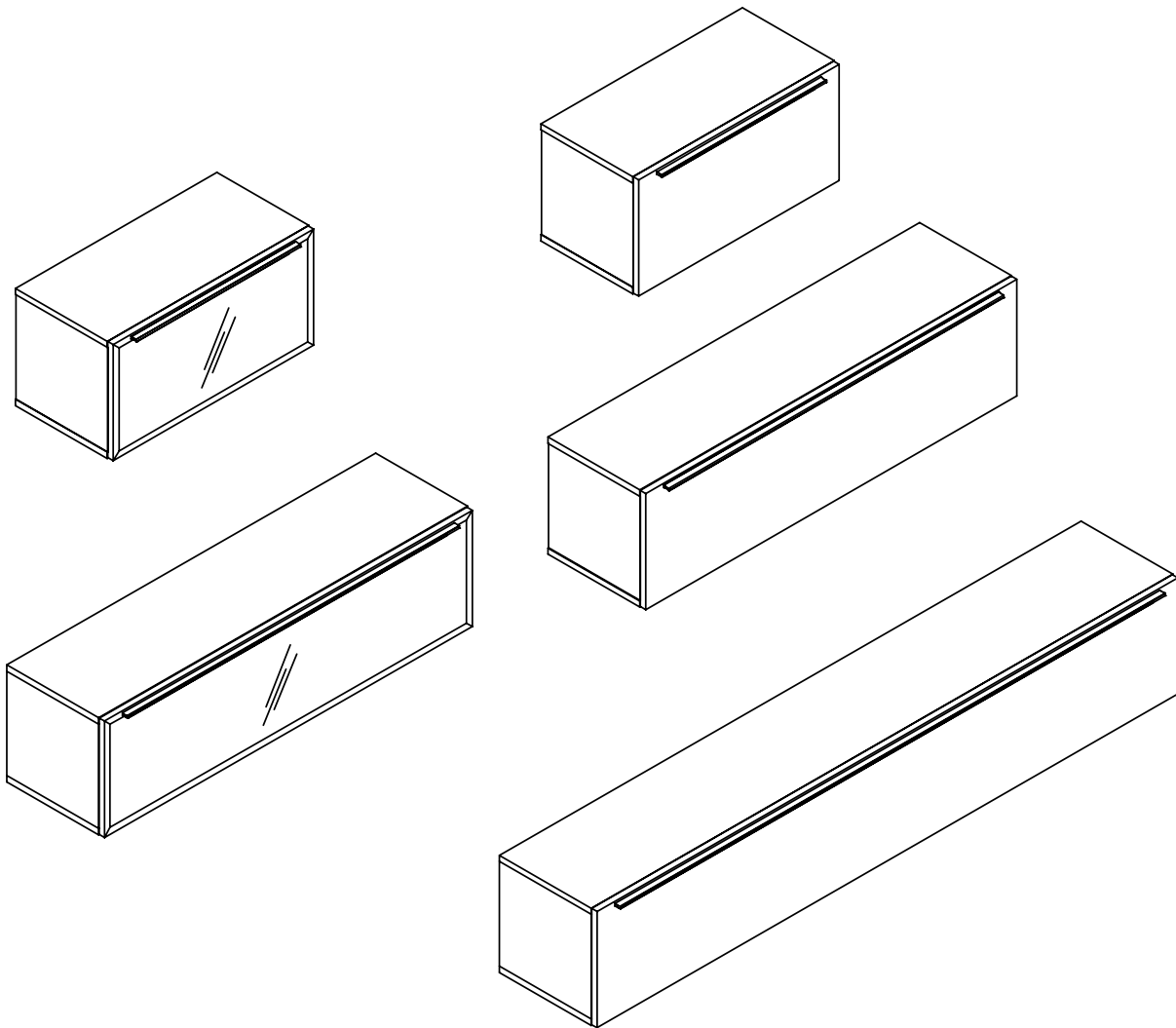

1358320

Lesen Sie zuerst die Anleitung und beginnen Sie dann mit der Montage

Before starting with the fitting, please read carefully the assembly instruction

Avant de commencer avec le montage, nous vous prions de bien lire le notice de montage

Voordat uw met de montage begint, a.u.b. de montagehandleiding lezen

MONTAGEANLEITUNG HÄNGEELEMENT 2R

TYP 4371 / 4372 / 4301 / 4302 / 4381 /
4382 / 4391 / 4392 / 4481 / 4482

WALL UNIT 2R
ELEMENT SUSPENDU 2U
HÄNGEELEMENT 2R



MONTAGEANLEITUNG · ASSEMBLY INSTRUCTION · NOTICE DE MONTAGE · MONTAGEHANDLEIDING

D:

Lieber now! by hülsta – Kunde,
sollten Sie – wider Erwarten - bei der Montage im Bereich der
beigepackten Beschläge Mängel in Form von:

- fehlenden Beschlagteilen
 - falschen Beschlagteilen
 - fehlerhaften Beschlagteilen (z.B. gebrochen, beschädigt o.ä.)
- feststellen, möchten wir Sie im Sinne einer zügigen und fehlerlosen
Abwicklung Ihrer Reklamation um folgende Angaben bitten:

1. Materialnummer des Beschlagkartons
2. Materialnummer und Stückzahl des Beschlagteils
3. Reklamationsgrund (z.B. fehlt, falsch, defekt, gebrochen...)
4. Packdatum (sofern vorhanden) der Beschlagkartonage
5. Prüfnummer (sofern vorhanden) auf dem Beschlagkarton

Diese Angaben können sie wahlweise per

E-mail: hotline@now.de

oder über die

now! by hülsta Servicehotline: 02563/ 86 – 1500

an uns weitergeben.

Mit freundlichen Grüßen

Ihr now! by hülsta - Team

GB:

Dear now! by hülsta customer,

If – contrary to expectations - there should be any discrepancies in the
accompanying fittings needed for assembly, such as:

- missing fittings
- incorrect fittings
- faulty fittings (e.g. broken, damaged, etc.)

we would like you to provide us with the following information so that your
complaint can be dealt with as quickly and successfully as possible:

1. Material number of fitting bracket packet
2. Material number and quantity of fitting brackets
3. Reason for complaint (e.g. part missing, incorrect, defective, broken...)
4. Date of packaging (if known) of fitting bracket packet
5. Check number (if known) on the fitting bracket packet

You can send us this data either by

e-mail: hotline@now.de

or by calling the

now! by hülsta service hotline: +49 (0) 2563 / 86 – 1500

With kind regards

Your now! by hülsta team

F:

Cher client now! by hülsta,

dans le cas où vous constateriez lors du montage, contrairement à nos intentions,
des anomalies dans le secteur des ferrures livrées se présentant sous les formes
suivantes:

- manque de certaines éléments des ferrures
- ferrures non adaptées
- éléments des ferrures défectueux (par exemple: cassées, abîmées ou similaires),
nous vous demandons de bien vouloir nous communiquer lors de votre réclamation
les données suivantes afin de permettre une réaction rapide et précise:

1. Référence du carton des ferrures
2. Référence et quantité de la pièce de la ferrure
3. Raison de la réclamation (par exemple: manque,
inadaptation, malfaçon, cassé ...)
4. Date d'emballage (si disponible) du carton des ferrures
5. Numéro de contrôle (si disponible) sur le carton de ferrures

Il vous est possible de nous communiquer ces données par

e-mail: hotline@now.de

ou en appelant notre

service hotline now! by hülsta: +49 (0) 2563 / 86 - 1500

Avec nos sincères salutations

L'équipe now! by hülsta

NL:

Geachte now! by hülsta-klant,

Indien u - tegen alle verwachtingen in - tijdens de montage m.b.t. de bijgepakte
beslagdelen klachten hebt, zoals:

- het ontbreken van bepaalde beslagdelen
- het onvoldoende ontvangen hebben van bepaalde beslagdelen
- of het hebben ontvangen van defecte beslagdelen

(bijv. gebroken of ernstig beschadigd),
dan verzoeken wij u - om uw reclamatie snel en correct te kunnen afwikkelen -
ons de volgende gegevens te verstrekken:

1. het materiaalnummer van de doos met beslagdelen
2. het materiaalnummer en het aantal stuks van de betr. beslagdelen
3. de reden van de reclamatie (bijv. ontbrak, verkeerd, defect, gebroken ...)
4. de inpakdatum op de doos met beslagdelen (indien voorhanden)
5. het controlnummer op de doos met beslagdelen (indien voorhanden)

Deze gegevens kunt u of per

e-mail: hotline@now.de

sturen, of per

now! by hülsta servicehotline: +49 (0) 2563 / 86 - 1500
telefonisch doorgeven.

Met vriendelijke groeten,

uw now! by hülsta-team

Angaben auf der Beschlagkartonage:

Data on fitting bracket packet:

Données sur le carton des ferrures:

Gegevens op de beslagdelendoos:

1. Materialnummer Beschlagkarton

1. Material number of fitting bracket packet

1. Référence du carton des ferrures
1. Materialnummer beslagdelendoos

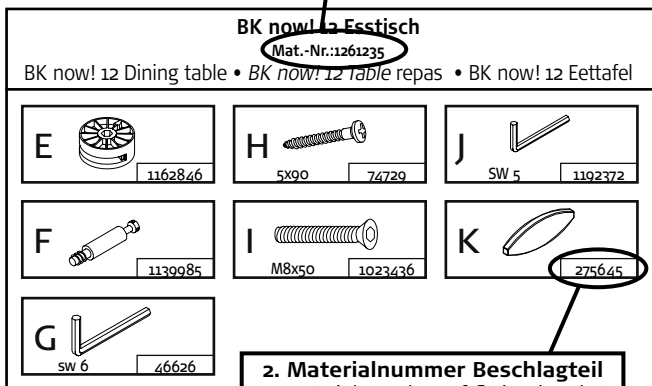

2. Materialnummer Beschlagteil

2. Material number of fitting bracket

2. Référence de la pièce de la ferrure
2. Materiaalnummer beslagdeel

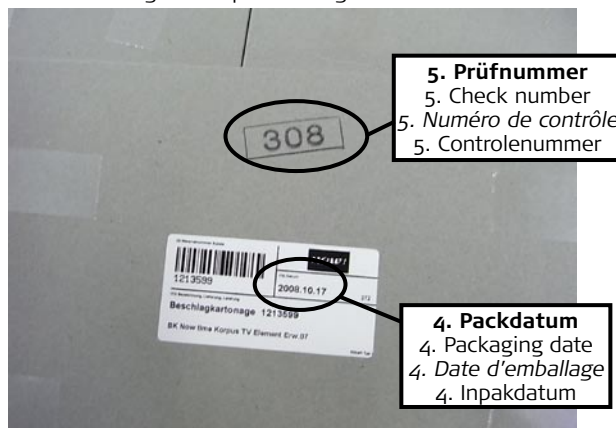

5. Prüfnummer

5. Check number
5. Numéro de contrôle
5. Controlnummer

4. Packdatum

4. Packaging date
4. Date d'emballage
4. Inpakdatum

MONTAGEANLEITUNG HÄNGEELEMENT 2R

TYP 4371 / 4372 / 4301 / 4302 / 4381 /
4382 / 4391 / 4392 / 4481 / 4482

WALL UNIT 2R
ELEMENT SUSPENDU 2U
HÄNGEELEMENT 2R



INHALT · CONTENTS · TABLE DES MATIERES · INHOUD

INHALT · CONTENTS · TABLE DES MATIERS · INHOUD SEITE · PAGE · PAGE · BLADZIJDE

Hängeelement 2R 70er Breite 4-15
Wall unit 2 R, 70 cm wide · *Élément suspendu 2U, 70 cm de large* · Hangelement 2 R, 70 cm breed

Gesamtübersicht 70er Breite 4-5
Summary 70 cm width · *Vue générale 70 cm de largeur* · Totaaloverzicht 70 cm breedte

Korpus 6-7
Carcase · *Corps* · Romp

Holzklappe 8-11
Wooden flap · *Abattant en bois* · Houten klep

Glasklappe 12-14
Glass flap · *Abattant en verre* · Glasklep

Aufhängung 15
Wall assembly · *Fixation murale* · Wandbevestiging

Hängeelement 2R 140er / 210er Breite 16-34
Wall unit 2 R, 140/210 cm wide · *Élément suspendu 2U, 140/210 cm de large* · Hangelement 2 R, 140/210 cm breed

Gesamtübersicht 140er Breite 16-17
Summary 140 cm width · *Vue générale 140 cm de largeur* · Totaaloverzicht 140 cm breedte

Gesamtübersicht 210er Breite 18-19
Summary 210 cm width · *Vue générale 210 cm de largeur* · Totaaloverzicht 210 cm breedte

Korpus 20-24
Carcase · *Corps* · Romp

Holzklappe 25-28
Wooden flap · *Abattant en bois* · Houten klep

Glasklappe 29-32
Glass flap · *Abattant en verre* · Glasklep

Aufhängung 32-34
Wall assembly · *Fixation murale* · Wandbevestiging

MONTAGEANLEITUNG HÄNGEELEMENT 2R 70ER BREITE

TYP 4371 / 4372 / 4301 / 4302





WALL UNIT 2 R, 70 CM WIDE
ELEMENT SUSPENDU 2U, 70 CM DE LARGE
HANGELEMENT 2 R, 70 CM BREED

now!
by hülsta





no.7

GESAMTÜBERSICHT · SUMMARY · VUE GENERALE · TOTAALOVERZICHT



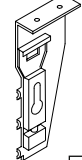

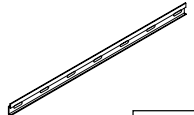
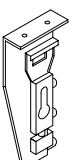

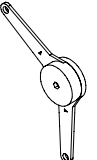

BK now! 7 Korpus Hänger Klappe
Mat.-Nr.: 1174527
BK now! 7 Carcase wall unit flap
BK now! 7 Corps élément suspendu abattant
BK now! 7 Romp hangelement klep

A  8x 16154	D  6x 3.5x15 275795
B  8x Ø 15x16 353643	E  4x 937822 Weiß • White • Blanc • Wit 937820 Schwarz • Black • Noir • Zwart
C  2x 275556	



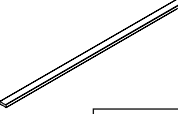





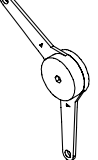

BK now! 7 Hängebeschlag
Mat.-Nr.: H59060000
BK now! 7 Mounting bracket
BK now! 7 Ferrure pour fixation murale
BK now! 7 Hangbevestiging

F  1x 911884	H  4x Ø 8mm 275620	L  1x 1184361
G  1x 911885	J  4x 3.5x13 275712	
	K  4x 5x60 176251	

BK now! 7 Holzklappe
Mat.-Nr.: 1174528
BK now! 7 Wooden flap
BK now! 7 Abattant en bois
BK now! 7 Houten klep

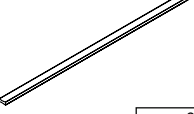
M  2x 1114592	R  12x 3.5x15 275795
N  2x 1114593	S  8x 1120627 Weiß • White • Blanc • Wit 1120625 Schwarz • Black • Noir • Zwart
O  2x 1143528	T  1x 1170852
P  2x 1032832	U  3x M4x25 456264
Q  2x 1176661	V  4x 121192

BK now! 7 Glasklappe
Mat.-Nr.: 1174529
BK now! 7 Glass flap
BK now! 7 Abattant en verre
BK now! 7 Glasklep

M  2x 1114592	R  8x 3.5x15 275795	W  4x M4x10 275919
E1  2x 1117408	S  8x 1120627 Weiß • White • Blanc • Wit 1120625 Schwarz • Black • Noir • Zwart	X  4x M3x8 16751
O  2x 1143528	T  1x 1170852	
F1  2x 1034299	U  3x M4x25 456264	
Q  2x 1176661	V  4x 121192	

Verehrter Kunde, hier haben Sie die Möglichkeit die mitgelieferten Schrauben nachzumessen!

Dear customer, here you find a possibility to measure the delivered screws!

Cher client, ici vous avez la possibilité de mesurer les vis livrées!

SEITE 4 Beste klant, hier heeft uw de mogelijkheid de schroeven te meten!



MONTAGEANLEITUNG HÄNGEELEMENT 2R 70ER BREITE

TYP 4371 / 4372 / 4301 / 4302

WALL UNIT 2 R, 70 CM WIDE
ELEMENT SUSPENDU 2U, 70 CM DE LARGE
HANGELEMENT 2 R, 70 CM BREED

now!
by hülsta

no.7

GESAMTÜBERSICHT · SUMMARY · VUE GENERALE · TOTAALOVERZICHT

Für die Montage wird benötigt:

Necessary for assembly:

Pour le montage il faut:

Benodigdheden voor de montage:

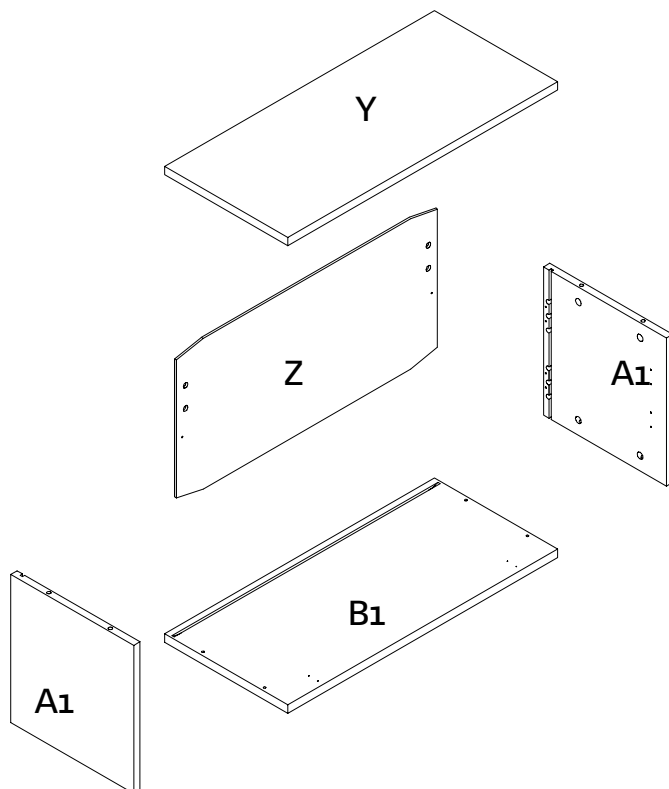
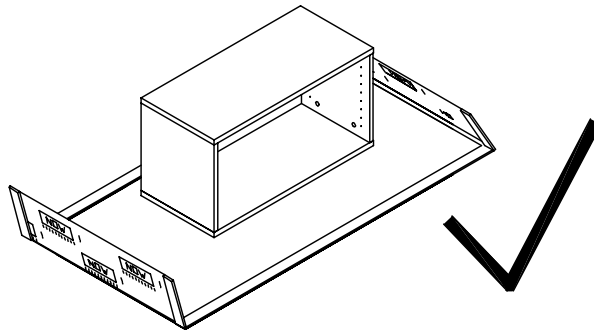
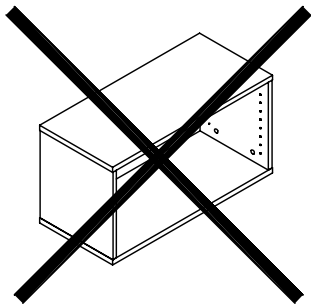
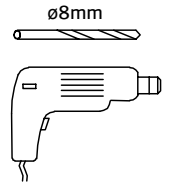
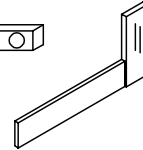
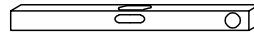
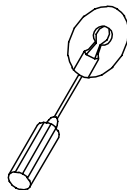
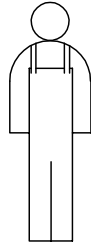

Holzklappe
Wooden flap
Abattant en bois
Houten klep

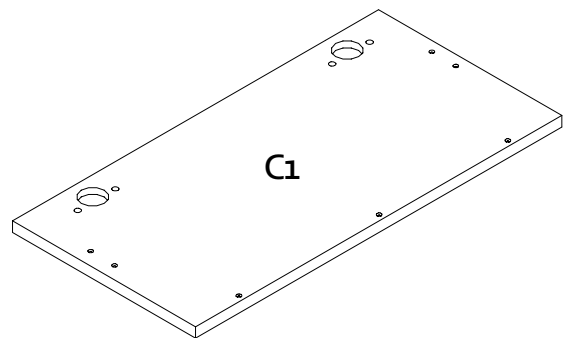

Glasklappe
Glass flap
Abattant en verre
Glasklep

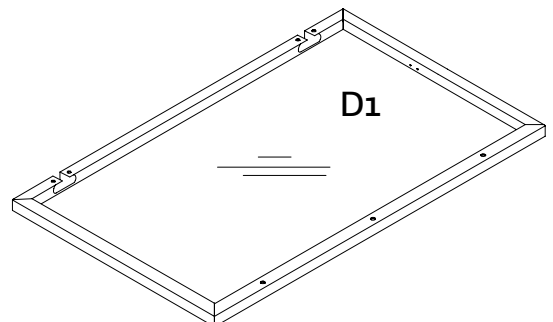

MONTAGEANLEITUNG HÄNGEELEMENT 2R 70ER BREITE

TYP 4371 / 4372 / 4301 / 4302

WALL UNIT 2 R, 70 CM WIDE
ELEMENT SUSPENDU 2U, 70 CM DE LARGE
HÄNGELELEMENT 2 R, 70 CM BREIT

now!
by hülsta

no.7

MONTAGE · ASSEMBLY · MONTAGE · MONTAGE

1

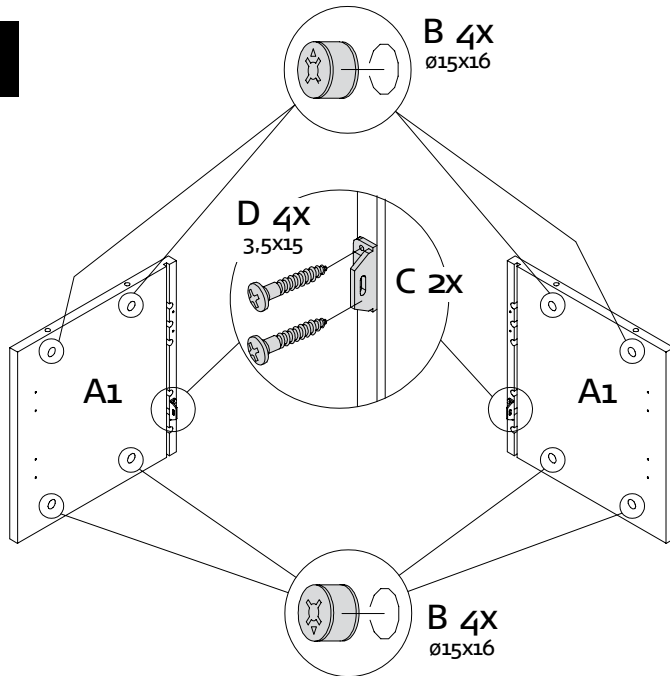

2

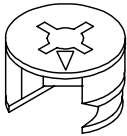
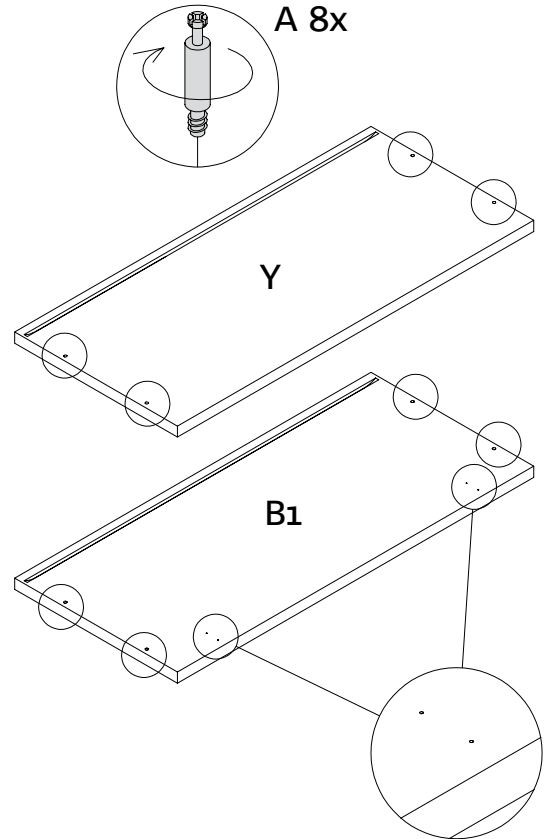

**Markierungsfeil muß zur Boh-
rung in der Bauteilkante zeigen!**

Arrow on cam must point to hole in
the edge of the panel!

*Placer la flèche repère au perçage
sur le chant de l'élément!*

Pijl in de kopse kant van betreffen-
de onderdeel wijzen!

3

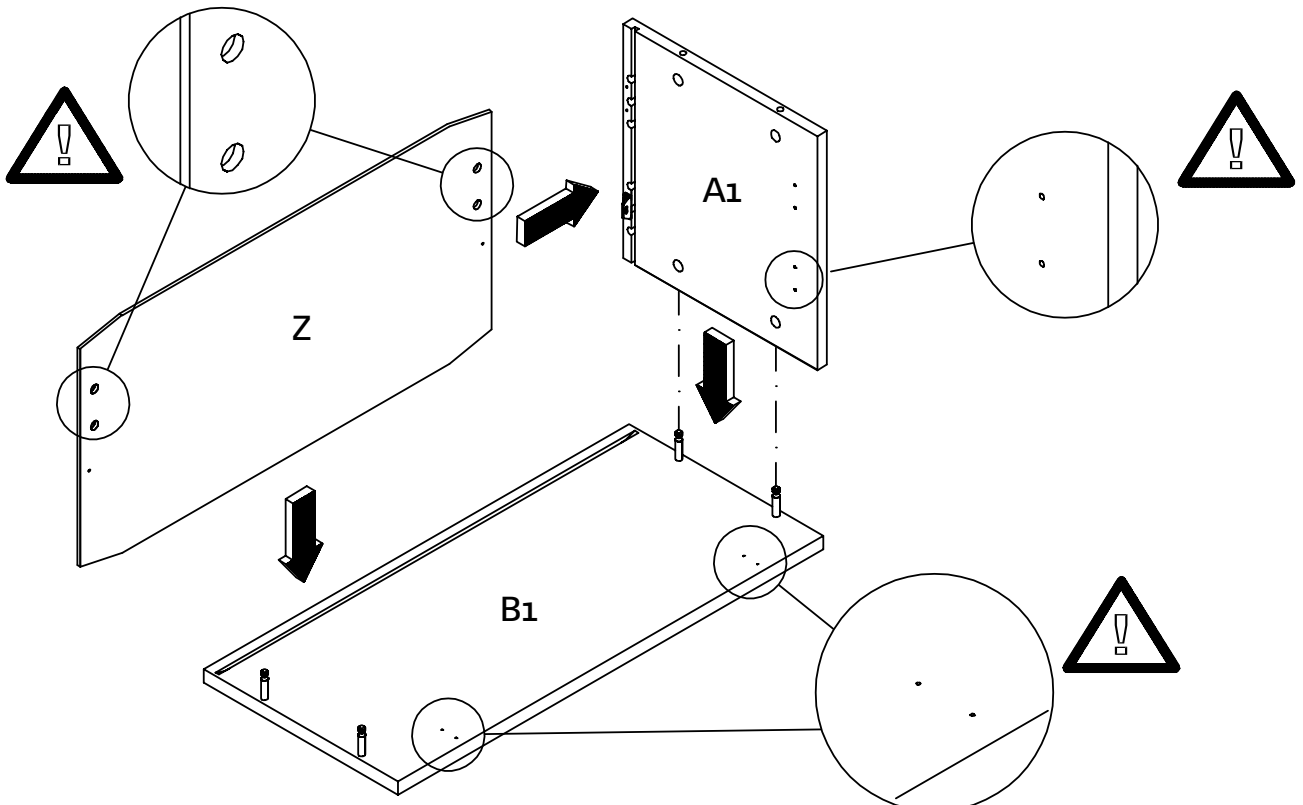

MONTAGEANLEITUNG HÄNGEELEMENT 2R 70ER BREITE

TYP 4371 / 4372 / 4301 / 4302

WALL UNIT 2 R, 70 CM WIDE
ELEMENT SUSPENDU 2U, 70 CM DE LARGE
HÄNGEELEMENT 2 R, 70 CM BREIT

now!
by hülsta

no.7

MONTAGE · ASSEMBLY · MONTAGE · MONTAGE

4

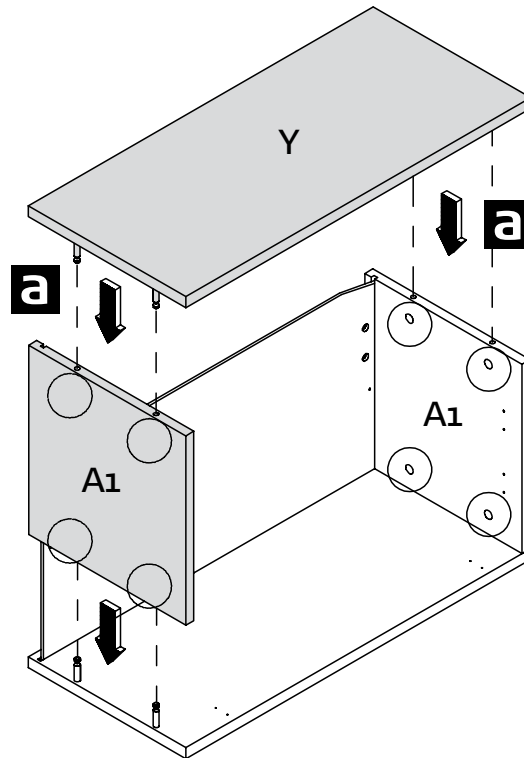
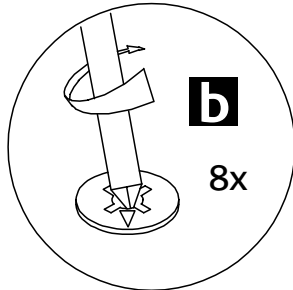

5

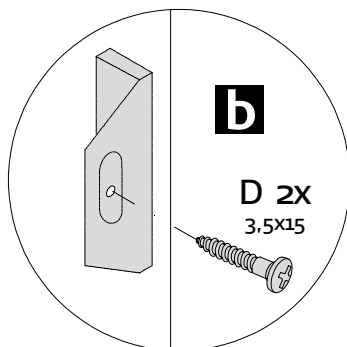
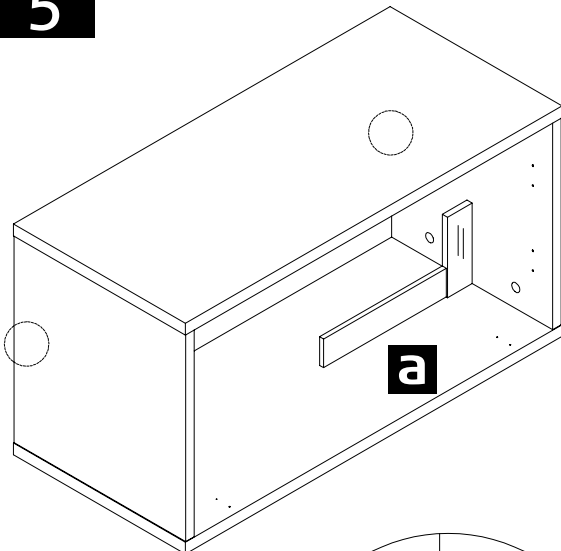

6

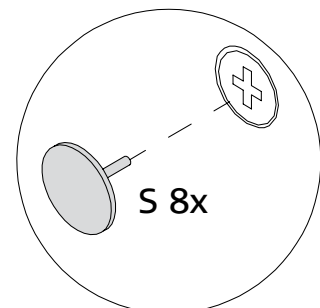
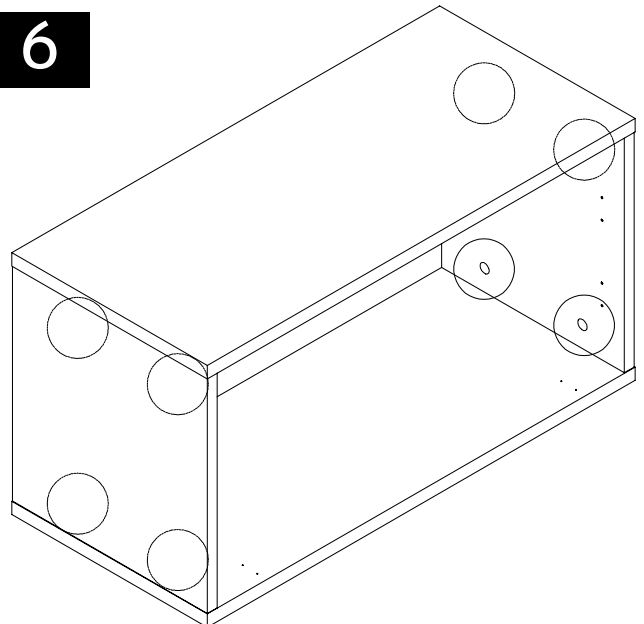

MONTAGEANLEITUNG
HÄNGEELEMENT 2R, 70ER BREITE - HOLZKLAPPE
 TYP 4371 / 4372



WALL UNIT 2 R, 70 CM WIDE - WOODEN FLAP
 ELEMENT SUSPENDU 2U, 70 CM DE LARGE - ABATTANT EN BOIS
 HANGELEMENT 2 R, 70 CM BREED - HOUTEN KLEP

MONTAGE · ASSEMBLY · MONTAGE · MONTAGE

7

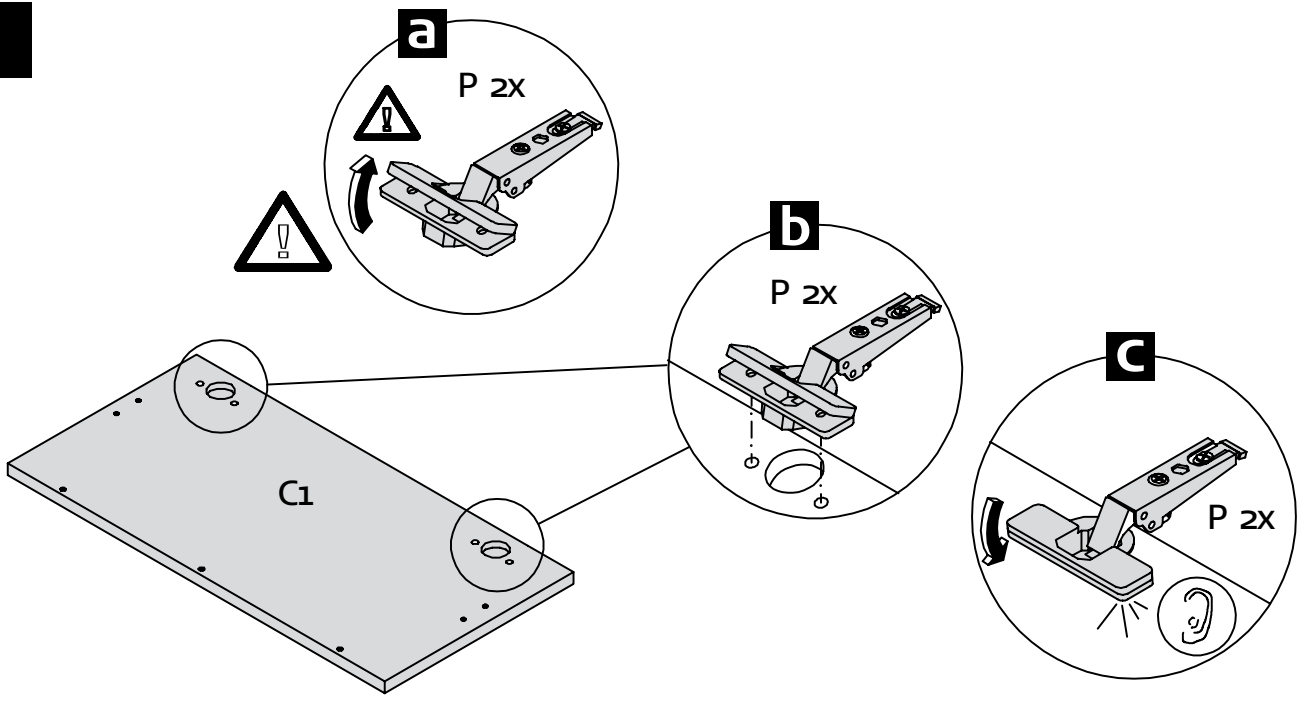

8

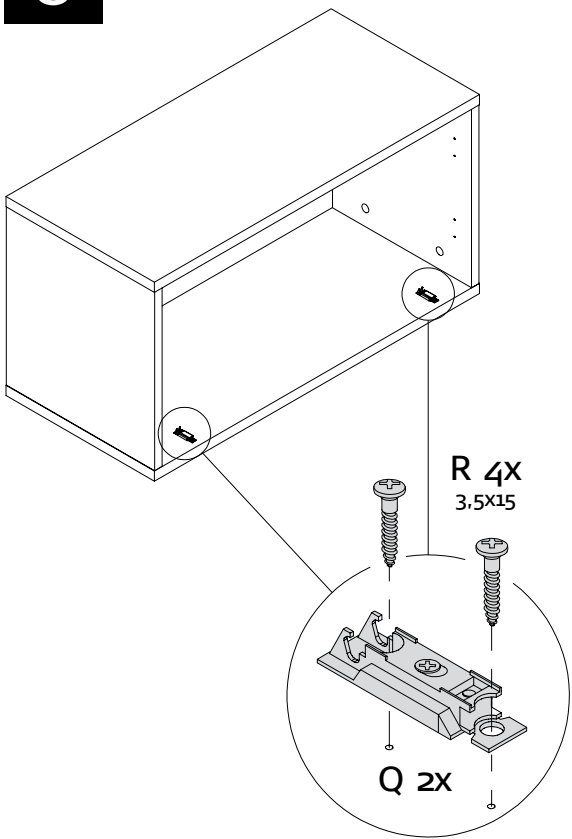

9

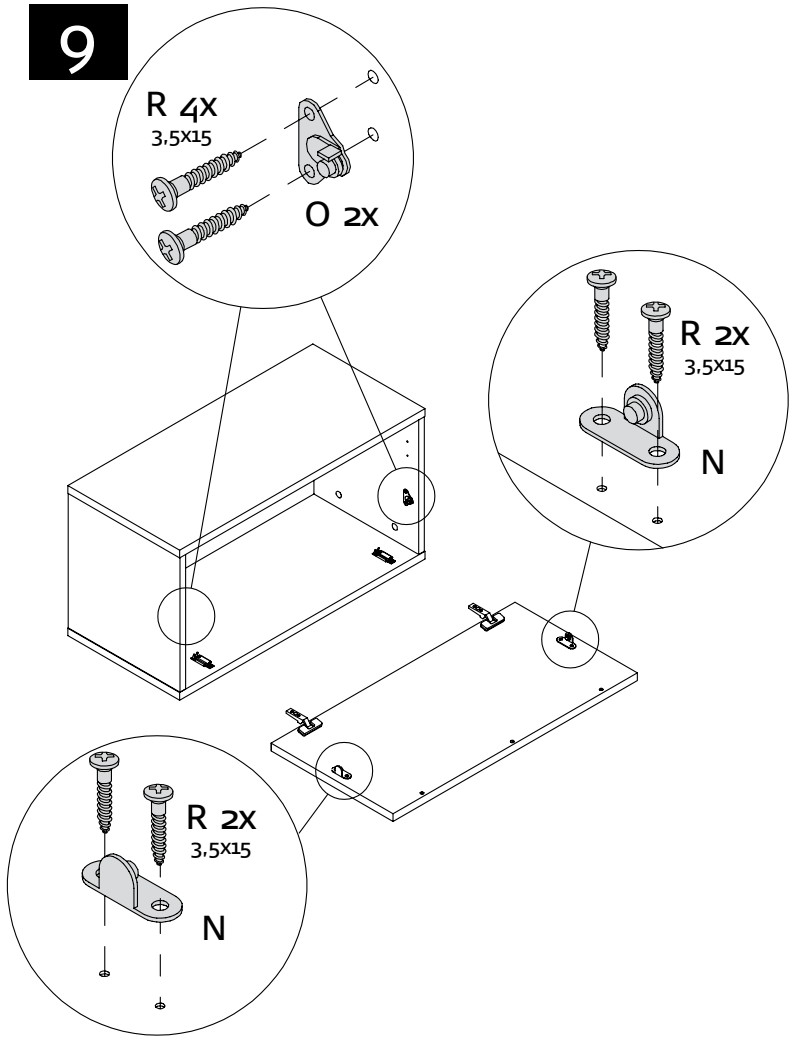

MONTAGEANLEITUNG HÄNGEELEMENT 2R 70ER BREITE - HOLZKLAPPE

TYP 4371 / 4372

WALL UNIT 2 R, 70 CM WIDE - WOODEN FLAP
ELEMENT SUSPENDU 2U, 70 CM DE LARGE - ABATTANT EN BOIS
HANGELEMENT 2 R, 70 CM BREED - HOUTEN KLEP

now!
by hülsta

no.7

MONTAGE · ASSEMBLY · MONTAGE · MONTAGE

10

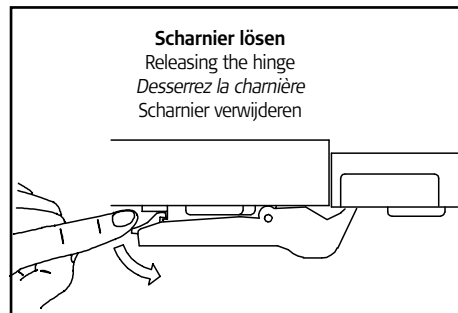
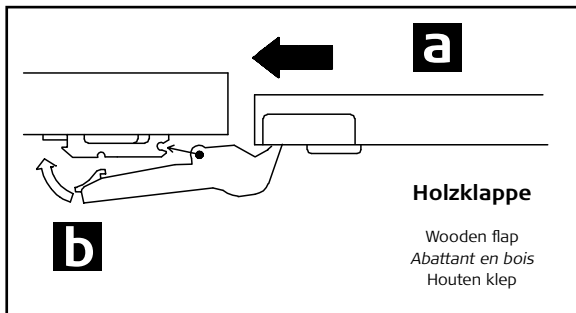
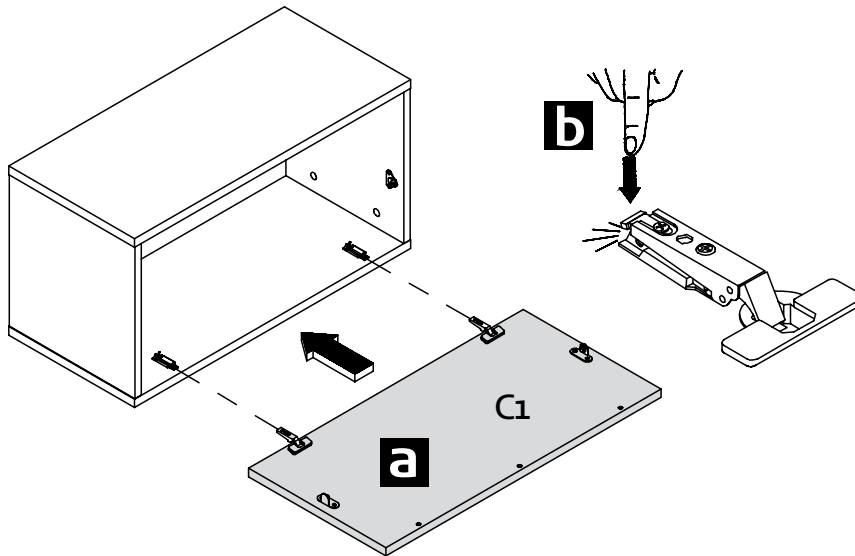

11

Falsch!
Wrong!
Incorrect!
Fout!



Richtig!
Correct!
Correct!
Correct!

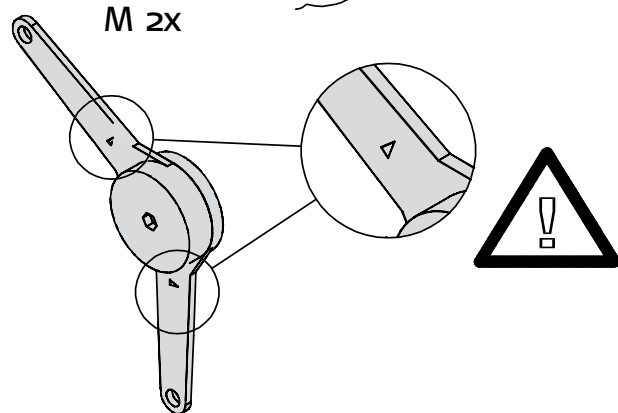
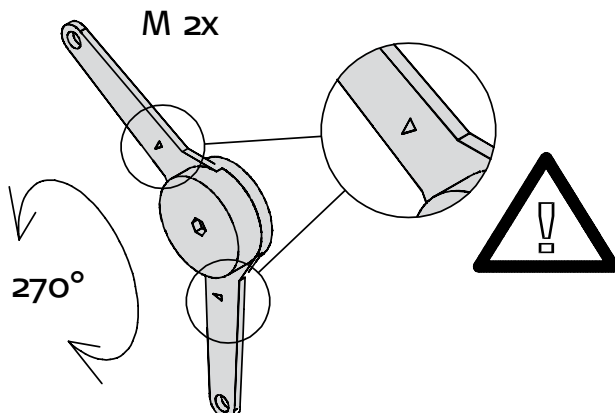

MONTAGEANLEITUNG HÄNGEELEMENT 2R 70ER BREITE - HOLZKLAPPE

TYP 4371 / 4372

WALL UNIT 2 R, 70 CM WIDE - WOODEN FLAP
ELEMENT SUSPENDU 2U, 70 CM DE LARGE - ABATTANT EN BOIS
HÄNGEELEMENT 2 R, 70 CM BREED - HOUTEN KLEP

now!
by hülsta

no.7

MONTAGE · ASSEMBLY · MONTAGE · MONTAGE

12

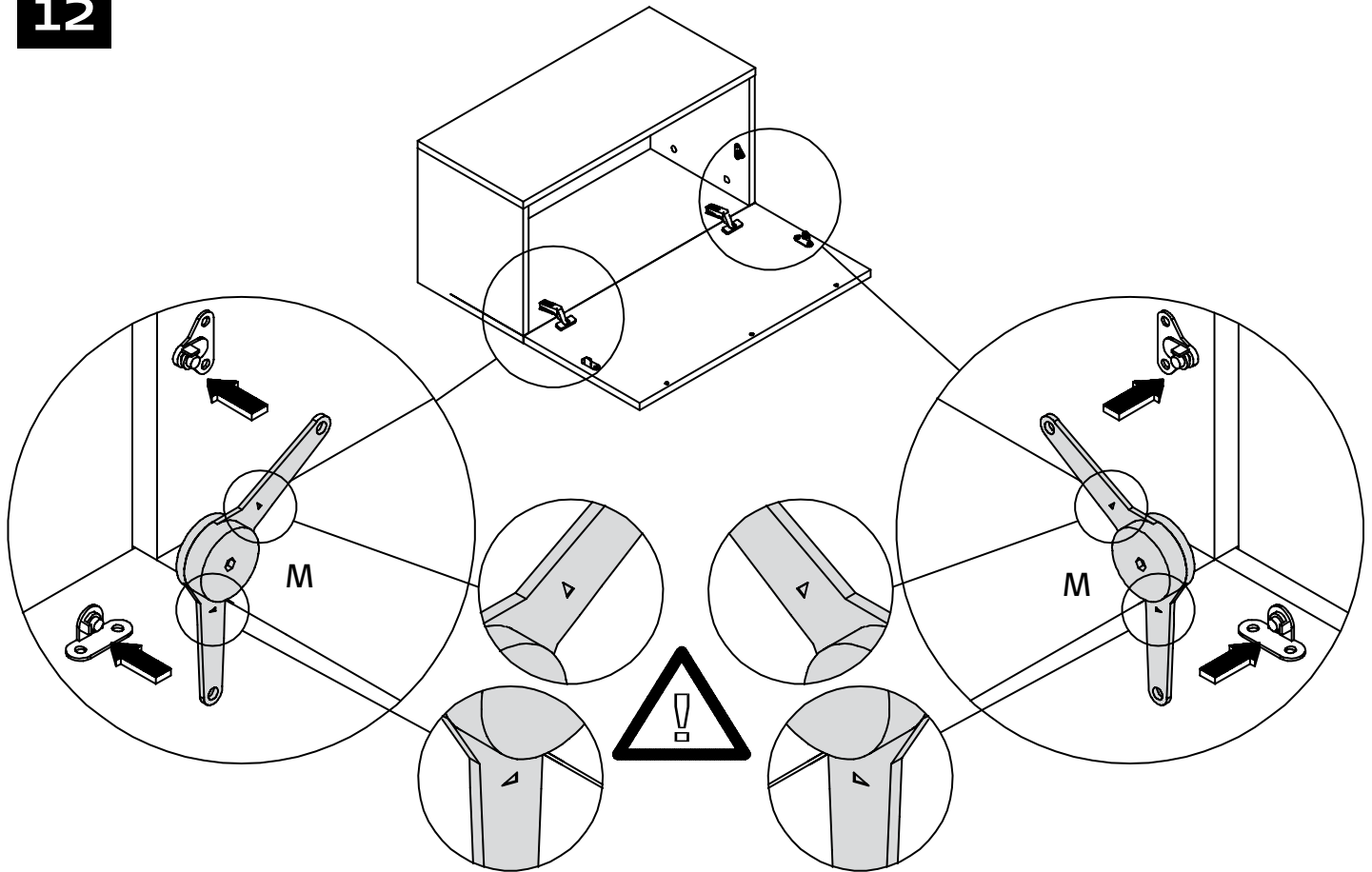

13

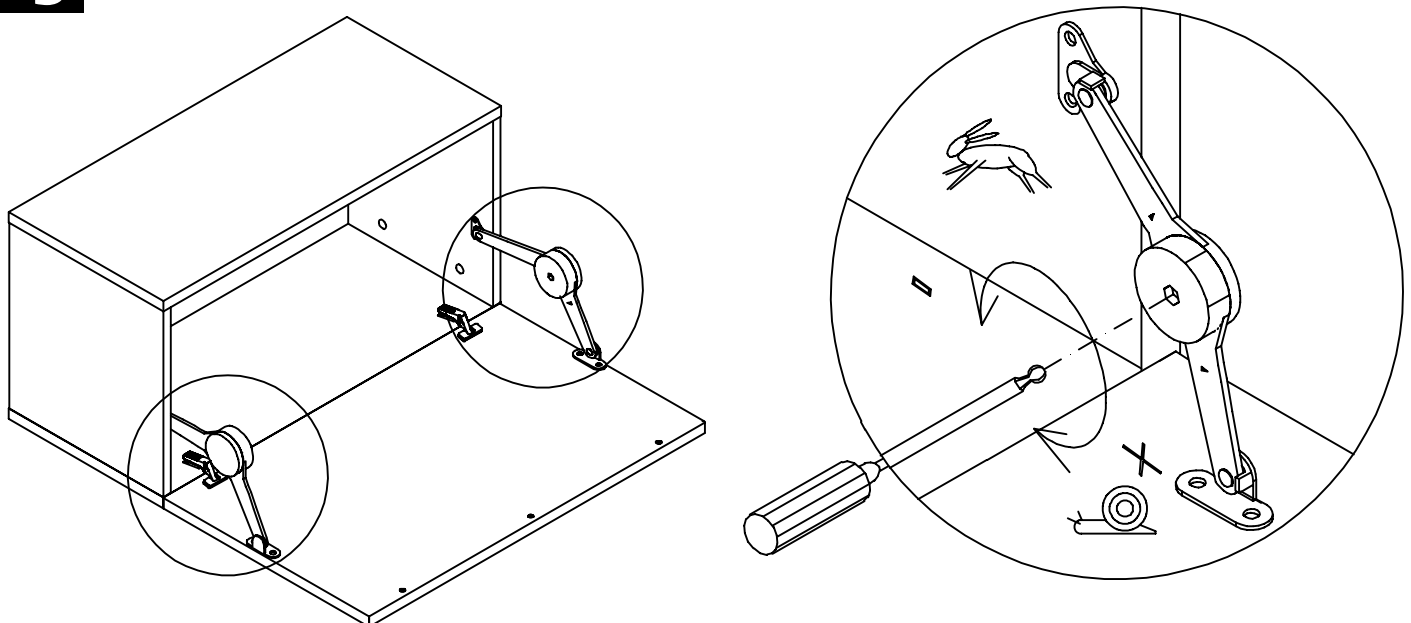

MONTAGEANLEITUNG HÄNGEELEMENT 2R 70ER BREITE - HOLZKLAPPE

TYP 4371 / 4372

WALL UNIT 2 R, 70 CM WIDE - WOODEN FLAP
ELEMENT SUSPENDU 2U, 70 CM DE LARGE - ABATTANT EN BOIS
HÄNGELEMANT 2 R, 70 CM BREED - HOUTEN KLEP

now!
by hülsta

no.7

MONTAGE · ASSEMBLY · MONTAGE · MONTAGE

14

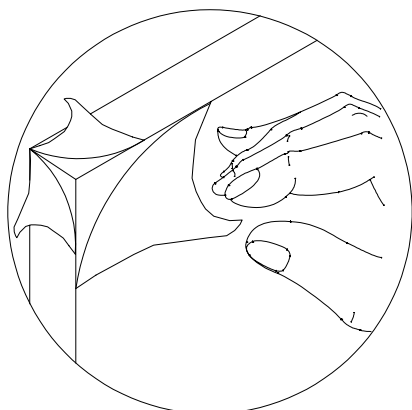

Schutzfolie abziehen!

Remove protective foil!
Enlever feuille de protection!
Beschermingsfolie aftrekken!

15

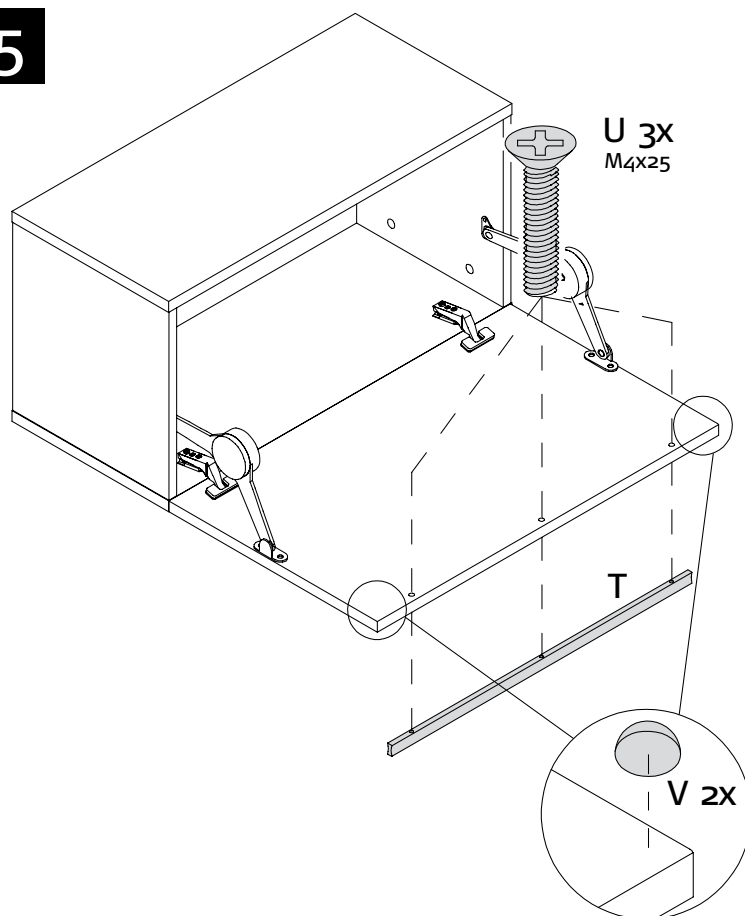

16

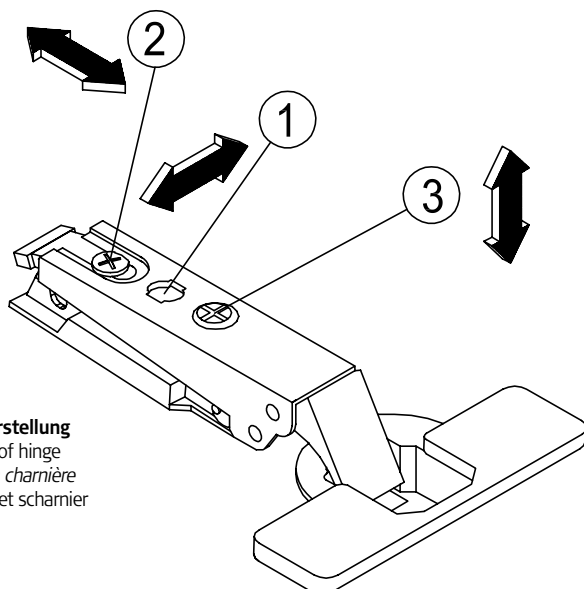

Scharniverstellung
Adjustment of hinge
Ajustage de la charnière
Afhangen van het scharnier

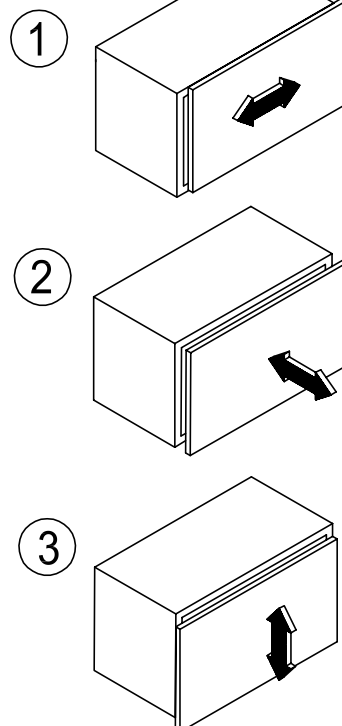

MONTAGEANLEITUNG HÄNGEELEMENT 2R 70ER BREITE - GLASKLAPPE

TYP 4301 / 4302

WALL UNIT 2 R, 70 CM WIDE - GLASS FLAP
ELEMENT SUSPENDU 2U, 70 CM DE LARGE - ABATTANT EN VERRE
HÄNGEELEMENT 2 R, 70 CM BREIT - GLASKLEP

now!
by hülsta

no.7

MONTAGE · ASSEMBLY · MONTAGE · MONTAGE

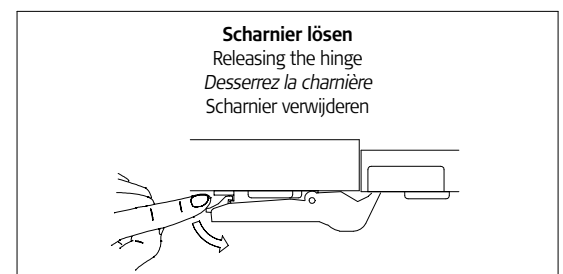
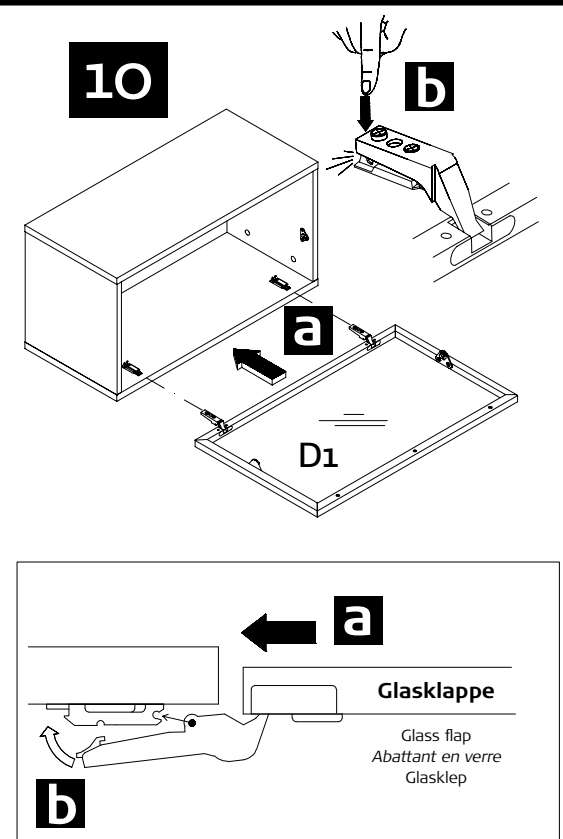
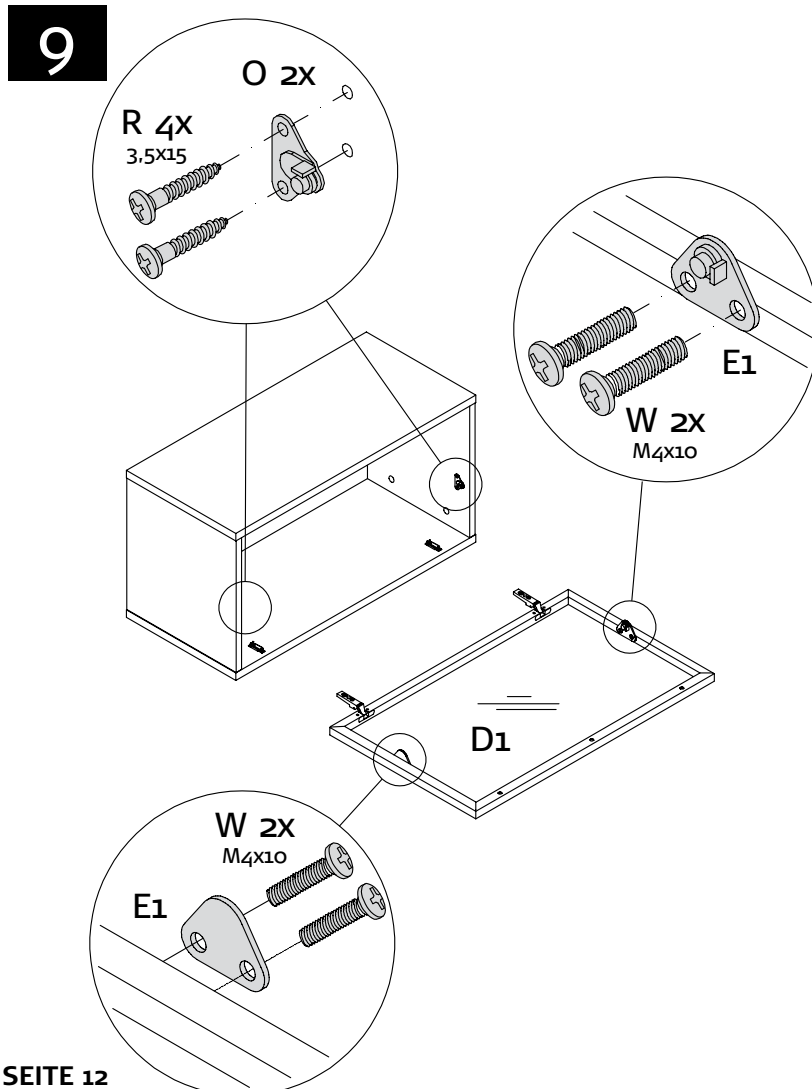
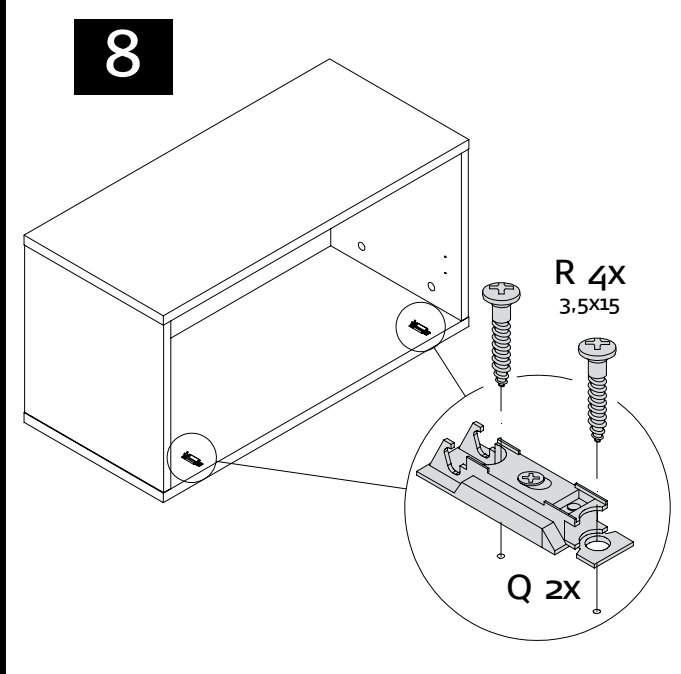
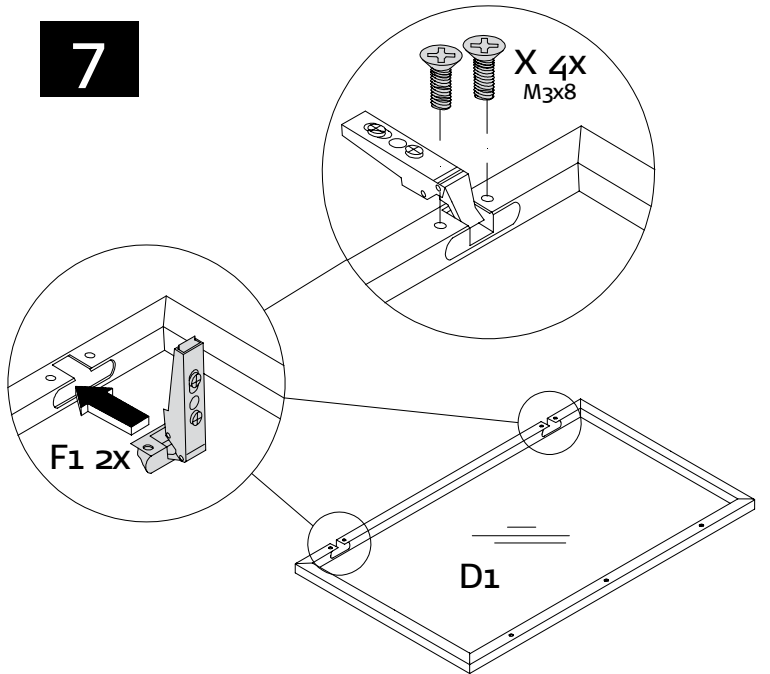

MONTAGEANLEITUNG
HÄNGEELEMENT 2R 70ER BREITE - GLASKLAPPE
 TYP 4301 / 4302



WALL UNIT 2 R, 70 CM WIDE - GLASS FLAP
 ELEMENT SUSPENDU 2U, 70 CM DE LARGE - ABATTANT EN VERRE
 HÄNGEELEMENT 2 R, 70 CM BREED - GLASKLEP

MONTAGE · ASSEMBLY · MONTAGE · MONTAGE

11

Falsch!
 Wrong!
 Incorrect!
 Fout!



Richtig!
 Correct!
 Correct!
 Correct!

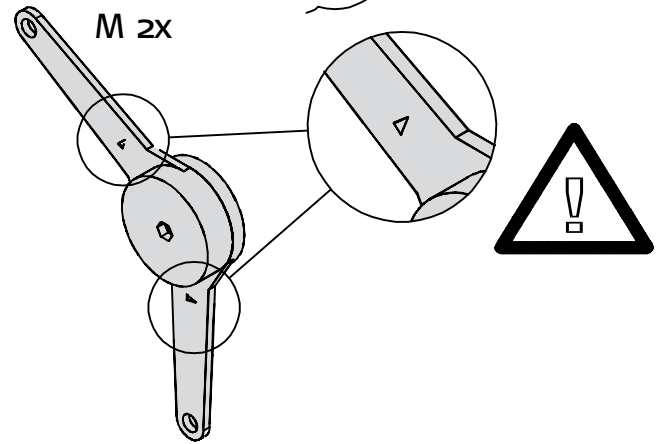
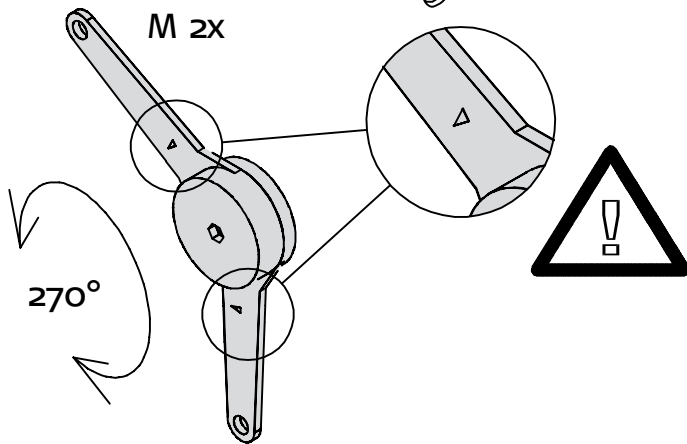

12

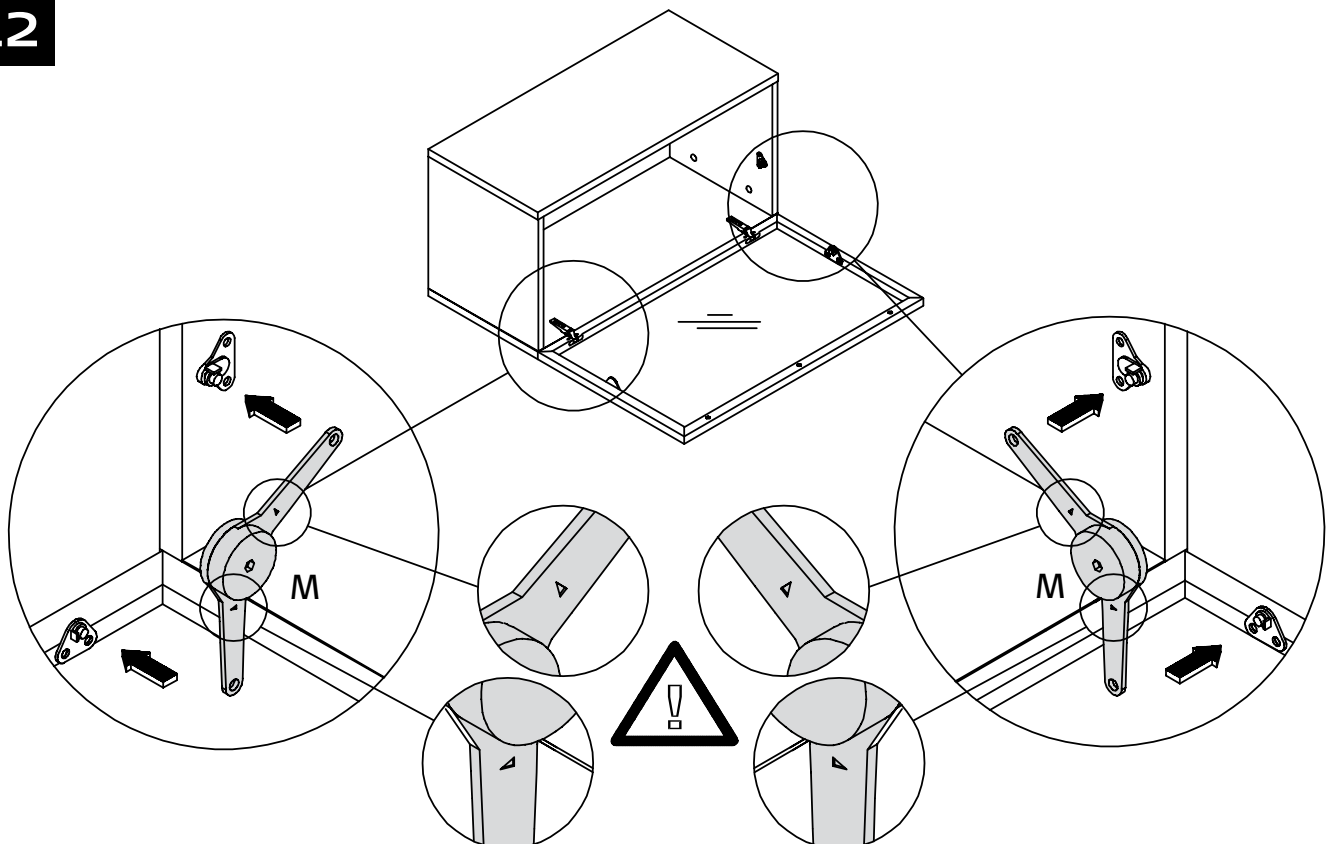

MONTAGEANLEITUNG
HÄNGEELEMENT 2R 70ER BREITE - GLASKLAPPE
 TYP 4301 / 4302



WALL UNIT 2 R, 70 CM WIDE - GLASS FLAP
 ELEMENT SUSPENDU 2U, 70 CM DE LARGE - ABATTANT EN VERRE
 HANGELEMENT 2 R, 70 CM BREED - GLASKLEP

MONTAGE · ASSEMBLY · MONTAGE · MONTAGE

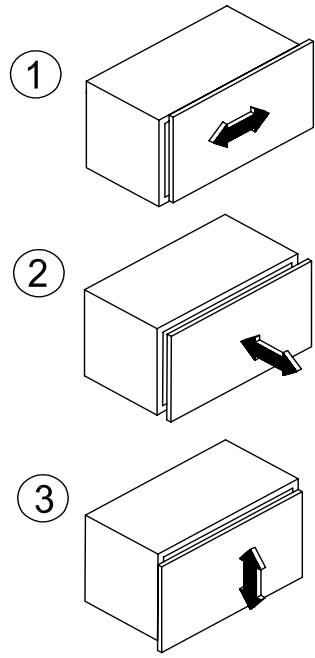
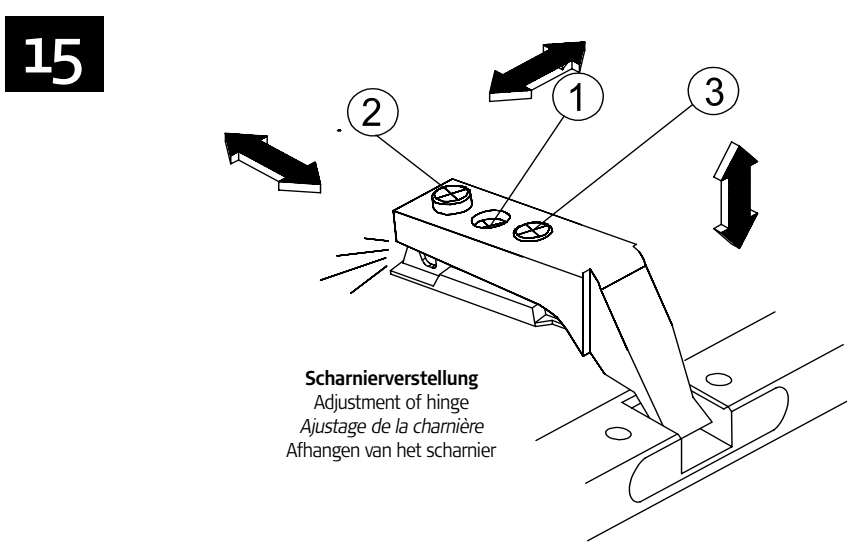
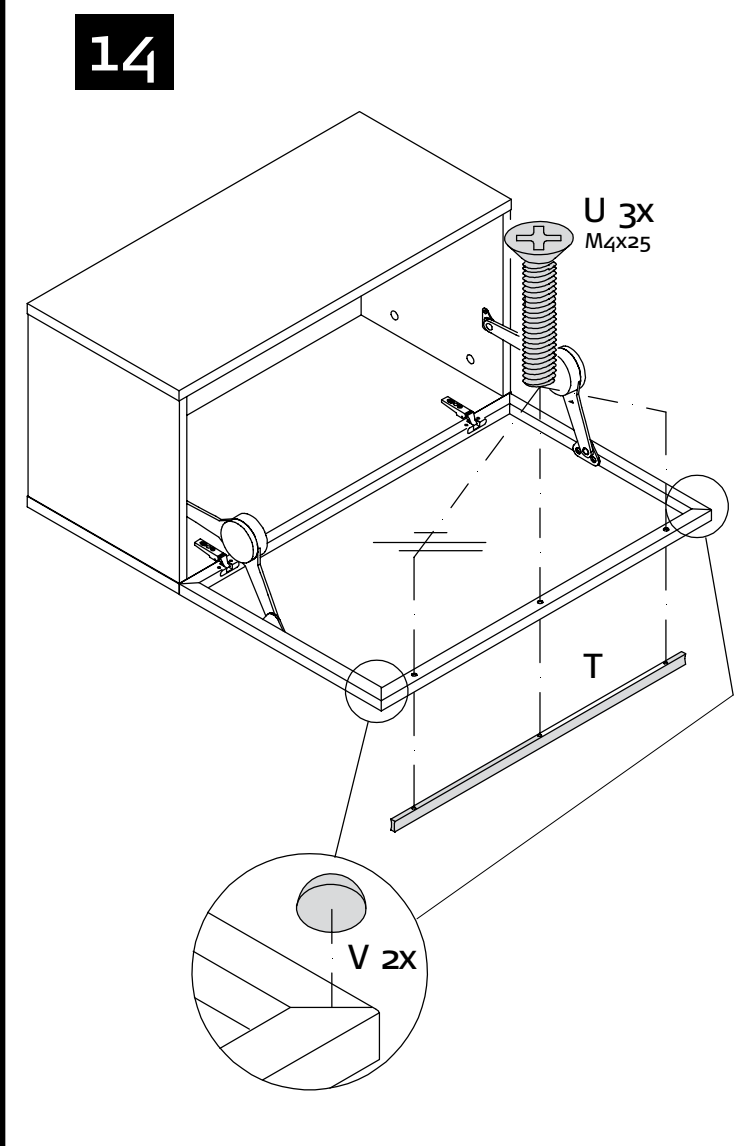
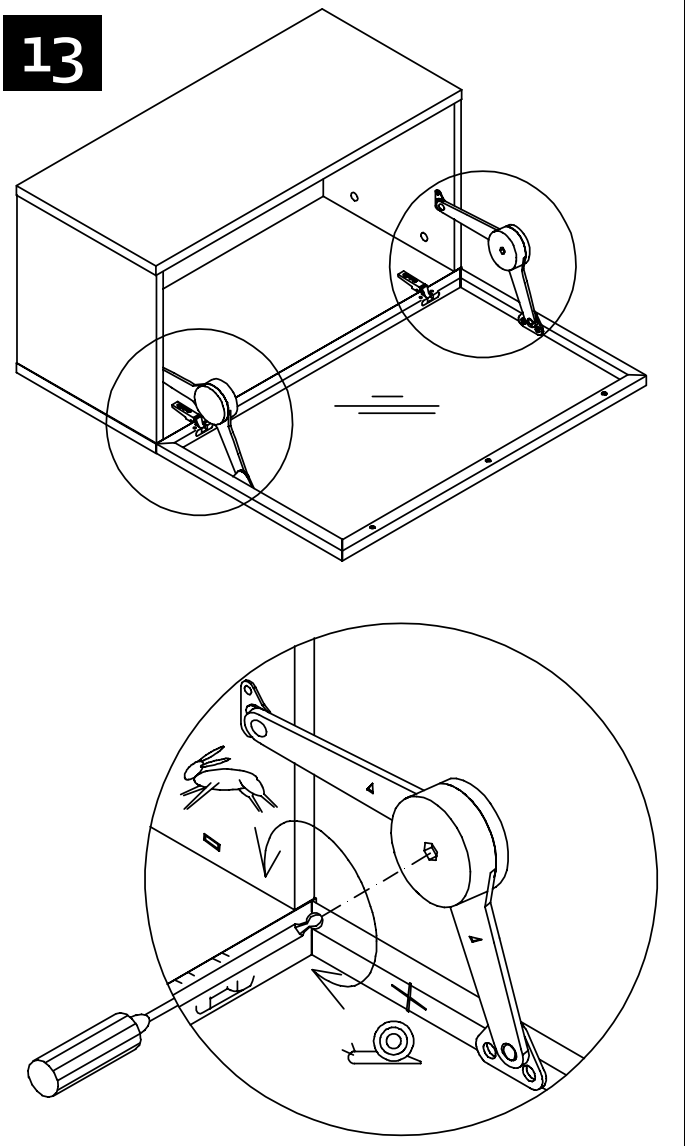

MONTAGEANLEITUNG HÄNGEELEMENT 2R 70ER BREITE - AUFHÄNGUNG

TYP 4371 / 4372 / 4301 / 4302

WALL UNIT 2 R, 70 CM WIDE - WALL ASSEMBLY
ELEMENT SUSPENDU 2U, 70 CM DE LARGE - FIXATION MURALE
HANGELEMENT 2 R, 70 CM BREED - WANDBEVESTIGING

now!
by hülsta

no.7

MONTAGE · ASSEMBLY · MONTAGE · MONTAGE

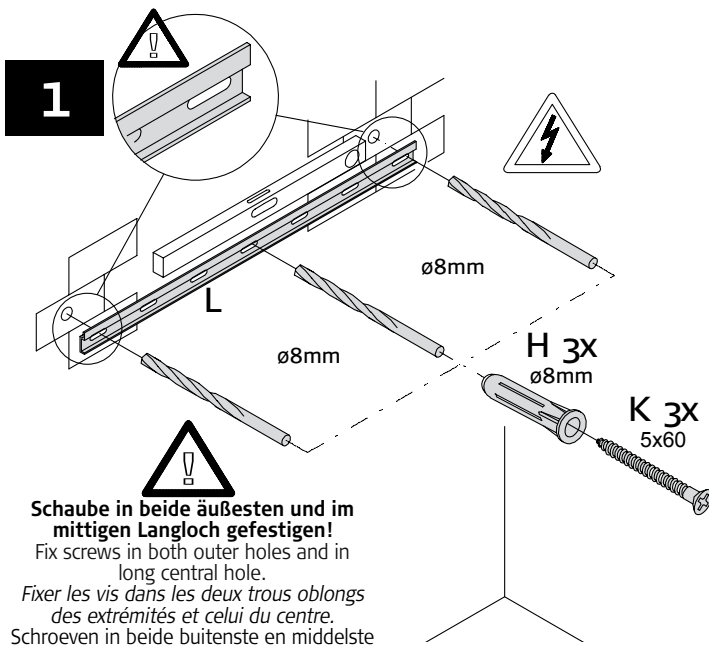

Wandbefestigung

Achtung! Die Wandbeschaffenheit ist vor der Montage unbedingt zu prüfen. Verwendung von Dübeln bei Beton und/oder festem Mauerwerk. Bei abweichender Beschaffenheit (z.B. Rahmenbauweise mit Gipskartonplatten, Leichtbausteinen etc.) ist eine andere, der Belastung angemessene Befestigung bauseits vorzunehmen. Beachten Sie, dass in dem Befestigungsbereich keine Elektro-Installationszonen und keine Ver- oder Entsorgungsleitungen vorhanden sein dürfen. Prüfen Sie mit einem geeigneten Leitungssuchgerät. Beachten Sie, dass Kunststoffrohre nicht detektiert werden.

Wall mounting

Please note! Please be sure to test the soundness of walls beforehand. Use plugs for concrete and solid walls. Use a different method that is capable of withstanding the load for lighter types of walls (e.g. framed gypsum plaster board, light brickwork, etc.). Please note that there must not be any electrical installations nor any electrical connections or leads of any kind in the assembly area. Please ensure this is so by testing the area with a suitable electrical leads search device. Please also note that plastic tubing will not be detected.

Fixation murale

Attention! La composition du mur doit absolument être contrôlée. Utilisation de chevilles pour le béton et/ou la maçonnerie dure. Pour les autres types de construction (cloisons en placoplâtre, maçonnerie légère, etc...), il faut prévoir un autre mode de fixation en rapport avec la charge. Veuillez contrôler l'absence d'installations électriques et de conduits dans le secteur de la fixation à l'aide d'un appareil. Veuillez noter que les tubes en matière synthétiques ne sont pas détectés.

Schraube in beide äußeren und im mittigen Langloch gefestigen!

Fix screws in both outer holes and in long central hole.

Fixer les vis dans les deux trous oblongs des extrémités et celui du centre.

Schroeven in beide buitenste en middelste sleufgat bevestigen

Gefahr bei fehlerhafter Montage!

Danger if not properly fitted!

Danger lors d'un montage incorrect!

Een verkeerde montage kan gevaarlijk zijn!

Bevestiging aan de muur

Attentie! Controleer, alvorens te beginnen, altijd de aard en de kwaliteit van de muur, waaraan gemonteerd moet worden. Gebruik voor de bevestiging aan beton en schoon metselwerk de door hülsta meegeleverde standaard pluggen en passende schroeven. In geval van muren van een ander, lichter soort materiaal (bijv. gipsplaten op een raamwerk of lichte bouwstenen) moet een ander, aan het draagvermogen aangepast speciaal bevestigingsmateriaal gebruikt worden. N.B.! In het muurgedeelte waar gemonteerd moet worden, mogen zich geen elektro-installatiezones bevinden resp. mogen geen aan- en/of afvoerleidingen (buizen) lopen. Dit kan gecontroleerd worden met speciale daarvoor bestemde detectieapparatuur. N.B.! Kunststoffleidingen kunnen helaas niet worden gedetecteerd.

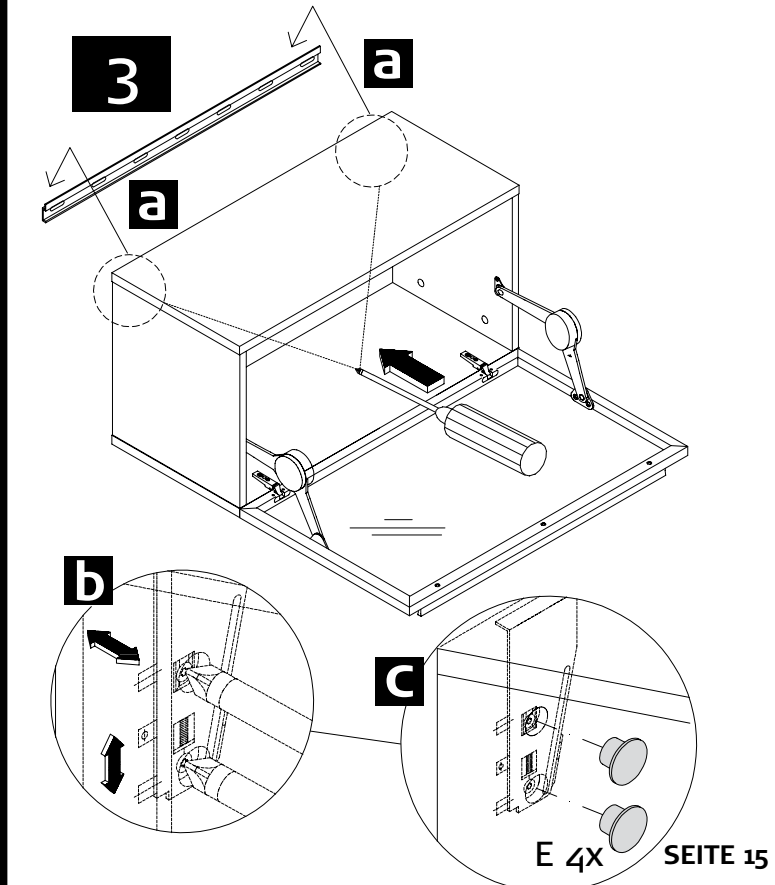
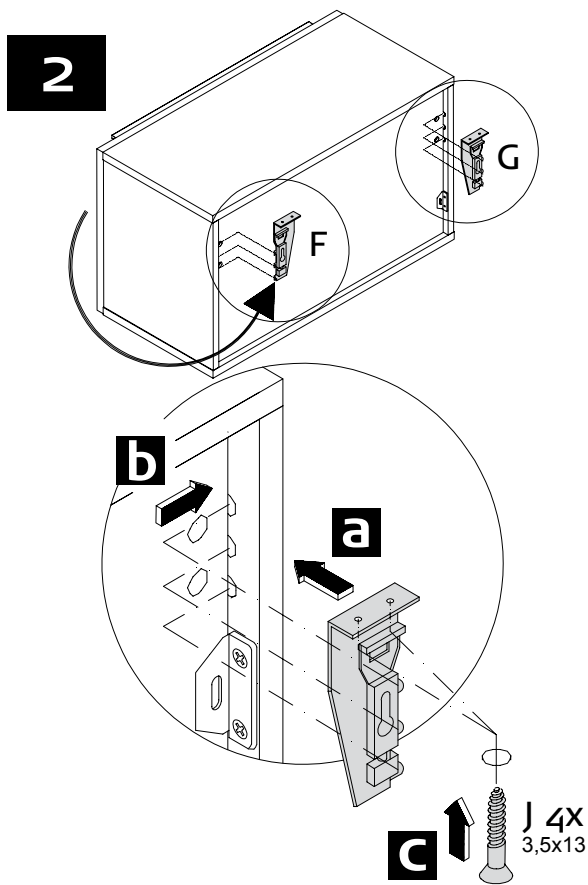

MONTAGEANLEITUNG HÄNGEELEMENT 2R 140ER BREITE







TYP 4381 / 4382 / 4391 / 4392

WALL UNIT 2 R, 140 CM WIDE
ELEMENT SUSPENDU 2U, 140 CM DE LARGE
HANGELEMENT 2 R, 140 CM BREED





now! **no.7**
by hülsta

GESAMTÜBERSICHT · SUMMARY · VUE GENERALE · TOTAALOVERZICHT



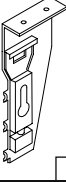

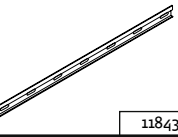
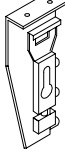

BK now! 7 2R Hänger 140 / 210er
Mat.-Nr.: 1358326
BK now! 7 Wall unit 2 R, 140/210 cm wide
BK now! 7 Élément suspendu 2U, 140/210 cm de large
BK now! 7 Hangelement 2 R, 140/210 cm breed

A  16x 16154	E  18x 3.5x35 275795
B  8x ø 15x16 353643	F  14x 937822 Weiß • White • Blanc • Wit 937820 Schwarz • Black • Noir • Zwart
C  6x ø 15x29 275556	G  18x 1120627 Weiß • White • Blanc • Wit 1120625 Schwarz • Black • Noir • Zwart
D  8x 316997	

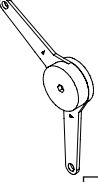





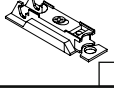

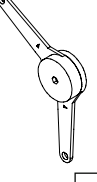

2 x BK now! 7 Hängebeschlag
Mat.-Nr.: H59060000
2x BK now! 7 Mounting bracket
2x BK now! 7 Ferrure pour fixation murale
2x BK now! 7 Hangbevestiging

H  2x 911884	K  8x ø 8mm 275620	N  2x 1184361
J  2x 911885	L  8x 3.5x13 275712	
	M  8x 5x60 176251	

BK now! 7 Holzklappe 140
Mat.-Nr.: 1358325
BK now! 7 Wooden flap 140
BK now! 7 Abattant en bois 140
BK now! 7 Houten klep 140

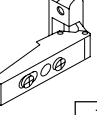
O  2x 1114592	T  14x 3.5x15 275795
P  2x 1114593	U  6x M4x25 456264
Q  2x 1143528	V  4x 1367749
R  3x 1032832	
S  3x 1176661	

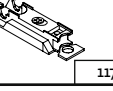
BK now! 7 Glasklappe 140
Mat.-Nr.: 1358327
BK now! 7 Glass flap 140
BK now! 7 Abattant en verre 140
BK now! 7 Glasklep 140

O  2x 1114592	T  10x 3.5x15 275795
G1  2x 1117408	U  6x M4x25 456264
Q  2x 1143528	V  4x 1367749
H1  3x 1034299	W  4x M4x10 275919
S  3x 1176661	X  6x M3x8 16751

Verehrter Kunde, hier haben Sie die Möglichkeit die mitgelieferten Schrauben nachzumessen!

Dear customer, here you find a possibility to measure the delivered screws!

Cher client, ici vous avez la possibilité de mesurer les vis livrées!

Beste klant, hier heeft uw de mogelijkheid de schroeven te meten!



MONTAGEANLEITUNG HÄNGEELEMENT 2R 140ER BREITE

TYP 4381 / 4382 / 4391 / 4392

WALL UNIT 2 R, 140 CM WIDE
ELEMENT SUSPENDU 2U, 140 CM DE LARGE
HÄNGEELEMENT 2 R, 140 CM BREED

now!
by hülsta

no.7

GESAMTÜBERSICHT · SUMMARY · VUE GENERALE · TOTAALOVERZICHT

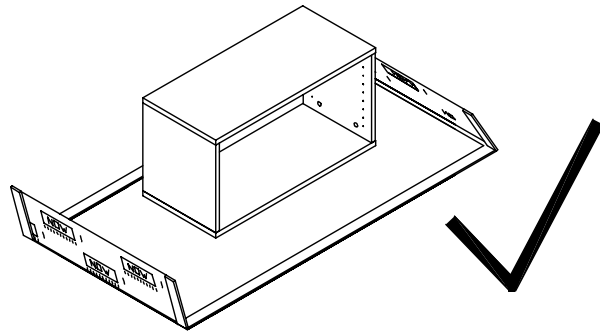
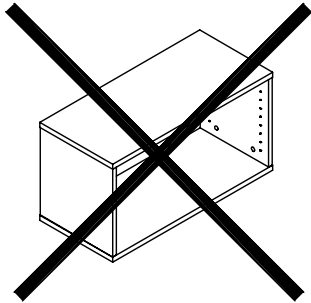

Für die Montage wird benötigt:

Necessary for assembly:

Pour le montage il faut:

Benodigdheden voor de montage:

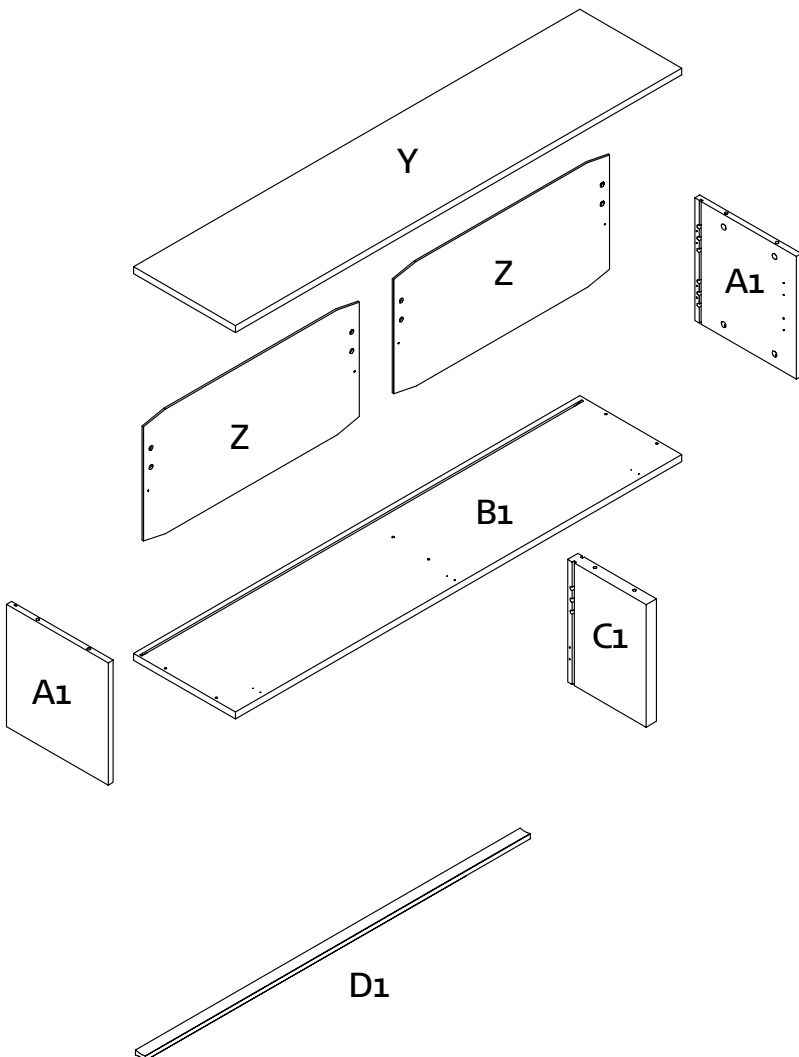
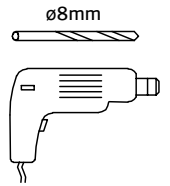
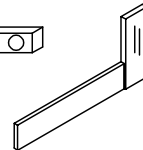
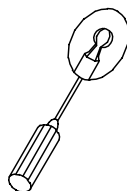
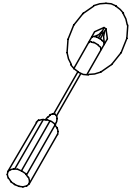
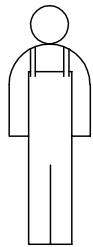

Holzklappe Wooden flap Abattant en bois Houten klep

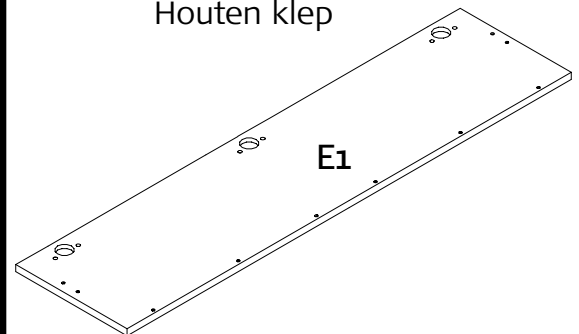

Glasklappe Glass flap Abattant en verre Glasklep

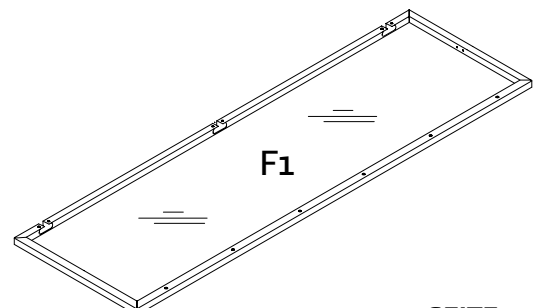

MONTAGEANLEITUNG HÄNGEELEMENT 2R 210ER BREITE

TYP 4481 / 4482







WALL UNIT 2 R, 210 CM WIDE
ELEMENT SUSPENDU 2U, 210 CM DE LARGE
HANGELEMENT 2 R, 210 CM BREED

now!
by hülsta





no.7

GESAMTÜBERSICHT · SUMMARY · VUE GENERALE · TOTAALOVERZICHT



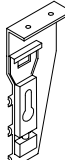

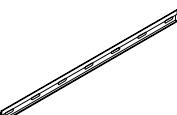
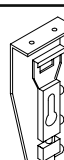

BK now! 7 2R Hänger 140 / 210er
Mat.-Nr.: 1358326
BK now! 7 Wall unit 2 R, 140/210 cm wide
BK now! 7 Élément suspendu 2U, 140/210 cm de large
BK now! 7 Hangelement 2 R, 140/210 cm breed

A  16x 16154	E  18x 3,5x15 275795
B  8x Ø 15x16 353643	F  14x 937822 Weiß • White • Blanc • Wit 937820 Schwarz • Black • Noir • Zwart
C  6x Ø 15x29 275556	G  18x 1120627 Weiß • White • Blanc • Wit 1120625 Schwarz • Black • Noir • Zwart
D  8x 316997	

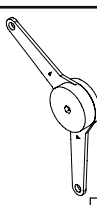
2 x BK now! 7 Hängebeslag
Mat.-Nr.: H59060000
2x BK now! 7 Mounting bracket
2x BK now! 7 Ferrure pour fixation murale
2x BK now! 7 Hangbevestiging

H  2x 911884	K  8x Ø 8mm 275620	N  2x 1184361
J  2x 911885	L  8x 3,5x13 275712	
	M  8x 5x60 176251	

BK now! 7 Holzklappe 210
Mat.-Nr.: 1358328
BK now! 7 Wooden flap 210
BK now! 7 Abattant en bois 210
BK now! 7 Houten klep 210

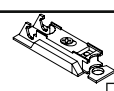
O  2x 1114592	T  16x 3,5x15 275795
P  2x 1114593	U  6x M4x25 456264
Q  2x 1143528	V  4x 1367749
R  4x 1032832	
S  4x 1176661	

Verehrter Kunde, hier haben Sie die Möglichkeit die mitgelieferten Schrauben nachzumessen!

Dear customer, here you find a possibility to measure the delivered screws!

Cher client, ici vous avez la possibilité de mesurer les vis livrées!

Beste klant, hier heeft uw de mogelijkheid de schroeven te meten!



MONTAGEANLEITUNG
HÄNGEELEMENT 2R 210ER BREITE
 TYP 4481 / 4482



WALL UNIT 2 R, 210 CM WIDE
 ELEMENT SUSPENDU 2U, 210 CM DE LARGE
 HANGELEMENT 2 R, 210 CM BREED

GESAMTÜBERSICHT · SUMMARY · VUE GENERALE · TOTAALOVERZICHT

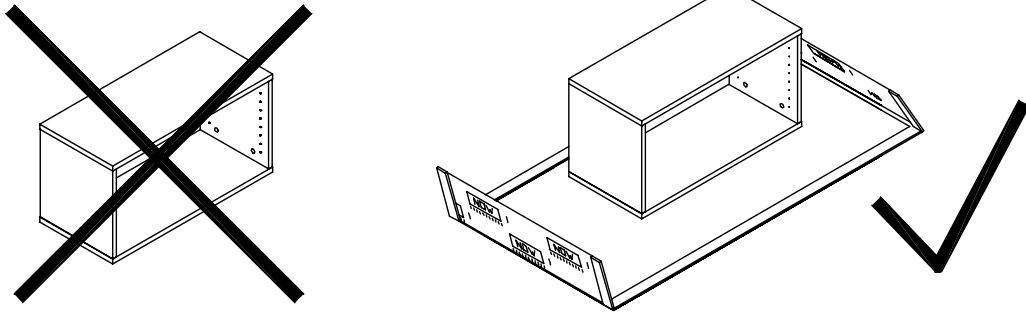

Für die Montage wird benötigt:
 Necessary for assembly:
 Pour le montage il faut:
 Benodigdheden voor de montage:

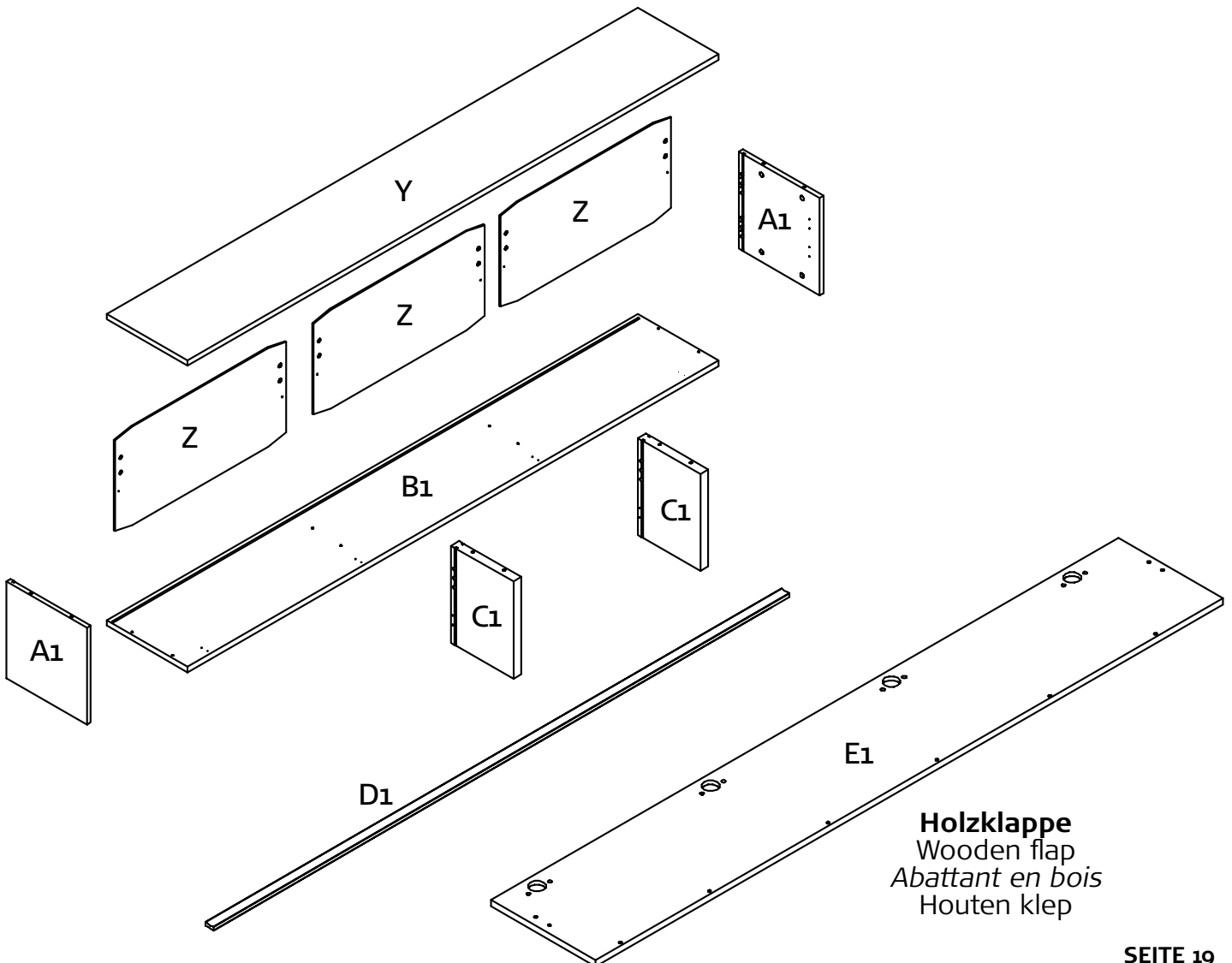
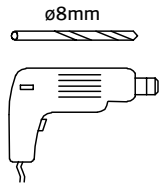
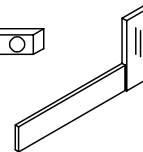
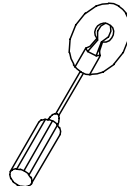
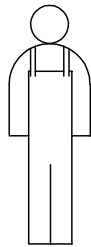

MONTAGEANLEITUNG
HÄNGEELEMENT 2R 140ER / 210ER
 TYP 4381 / 4382 / 4391 / 4392 / 4481 / 4482

WALL UNIT 2 R, 140/210 CM WIDE
 ELEMENT SUSPENDU 2U, 140/210 CM DE LARGE
 HANGELEMENT 2 R, 140/210 CM BREED

now!
 by hülsta

no.7

MONTAGE · ASSEMBLY · MONTAGE · MONTAGE

1

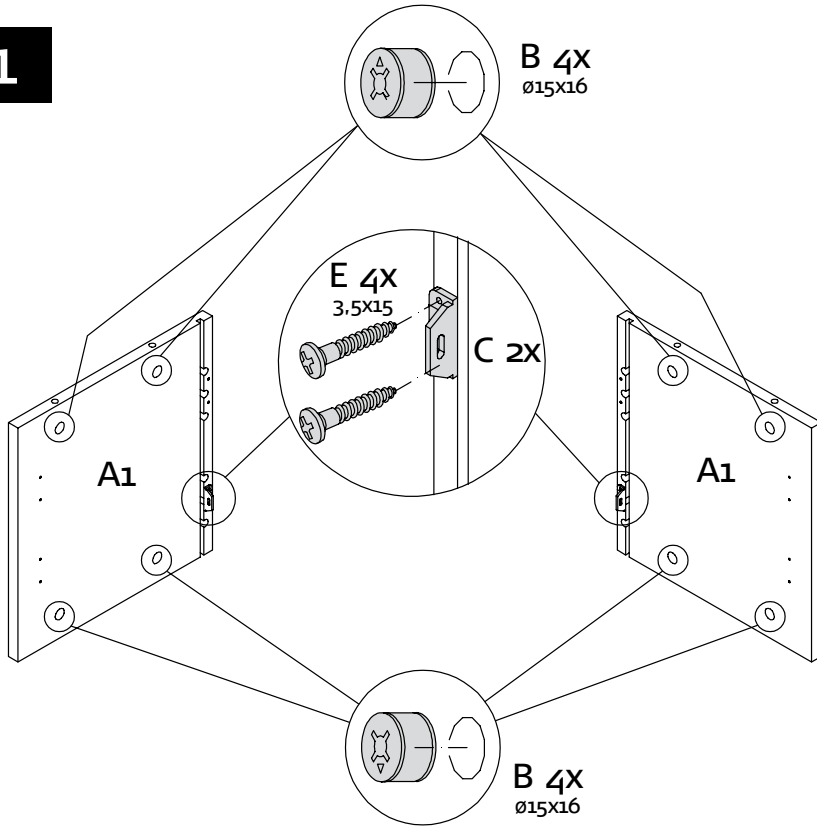

Markierungspfeil muß zur Bohrung in der Bauteilkante zeigen!
 Arrow on cam must point to hole in the edge of the panel!
Placer la flèche repère au perçage sur le chant de l'élément!
 Pijl in de kopse kant van betreffende onderdeel wijzen!

2

Typ 4381, 4382, 4391, 4392
 Type
 Réf.
 Type

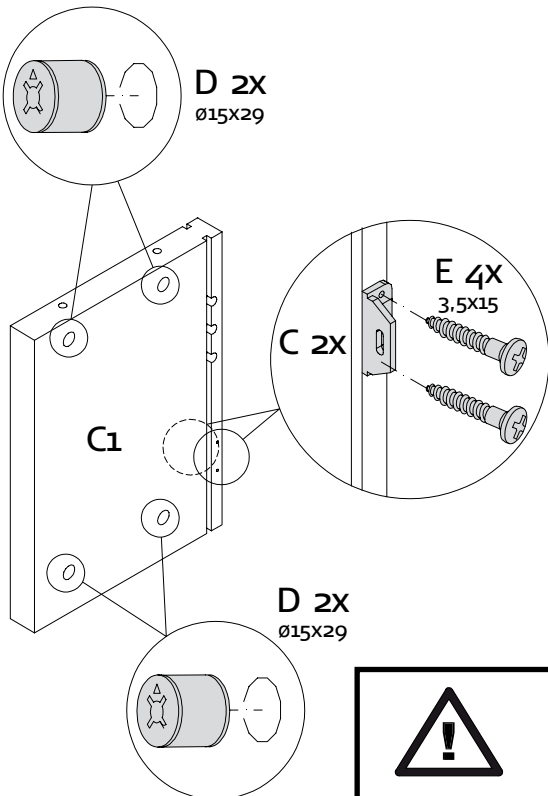

2

Typ 4481, 4482
 Type
 Réf.
 Type

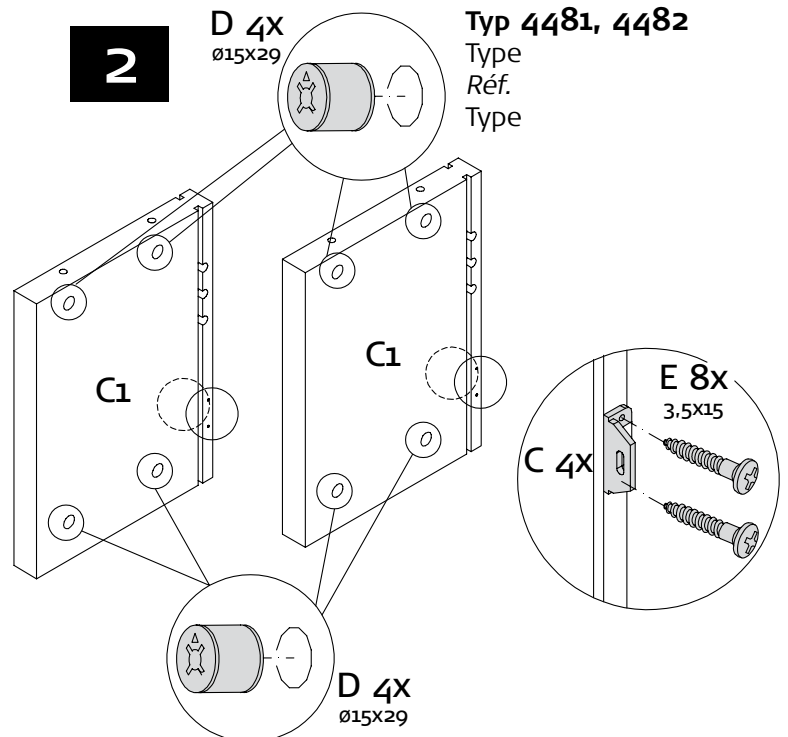

Markierungspfeil muß zur Bohrung in der Bauteilkante zeigen!
 Arrow on cam must point to hole in the edge of the panel!
Placer la flèche repère au perçage sur le chant de l'élément!
 Pijl in de kopse kant van betreffende onderdeel wijzen!

MONTAGEANLEITUNG
HÄNGEELEMENT 2R 140ER / 210ER
TYP 4381 / 4382 / 4391 / 4392 / 4481 / 4482

WALL UNIT 2 R, 140/210 CM WIDE
 ELEMENT SUSPENDU 2U, 140/210 CM DE LARGE
 HANGELEMENT 2 R, 140/210 CM BREED



MONTAGE · ASSEMBLY · MONTAGE · MONTAGE

3

Typ 4381, 4382, 4391, 4392
 Type
 Réf.
 Type

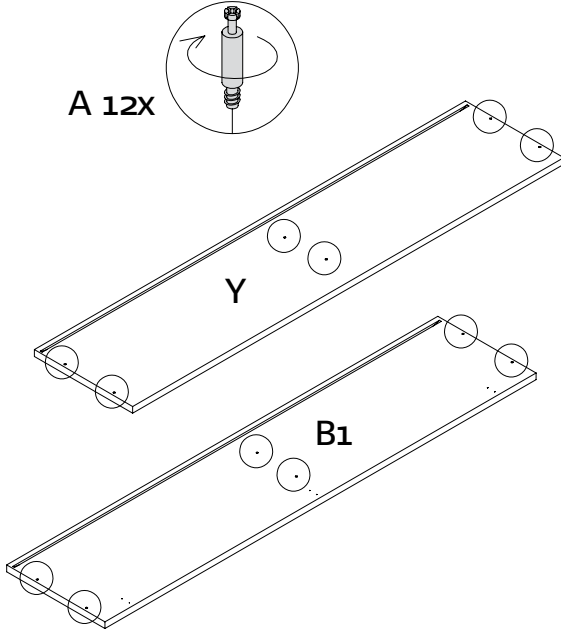

3

Typ 4481, 4482
 Type
 Réf.
 Type

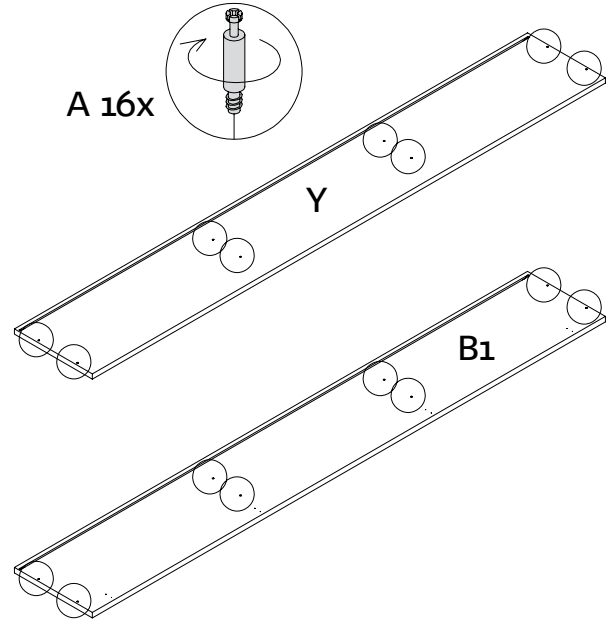

4

Typ 4381, 4382, 4391, 4392
 Type
 Réf.
 Type

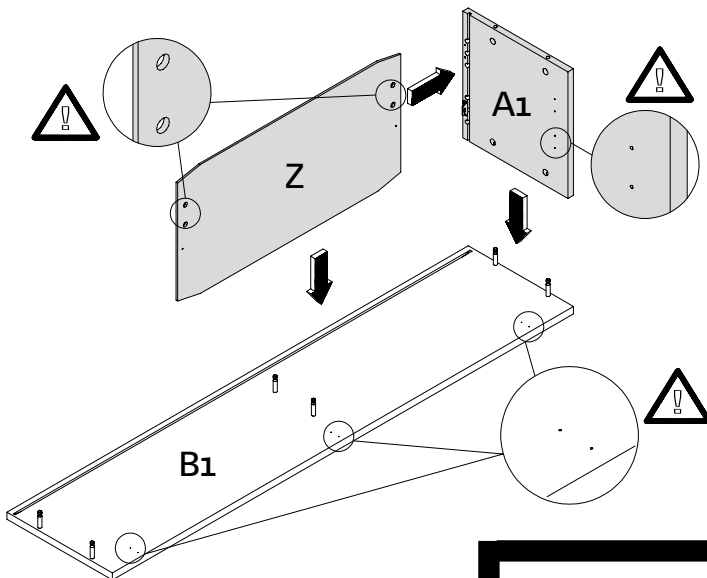

4

Typ 4481, 4482
 Type
 Réf.
 Type

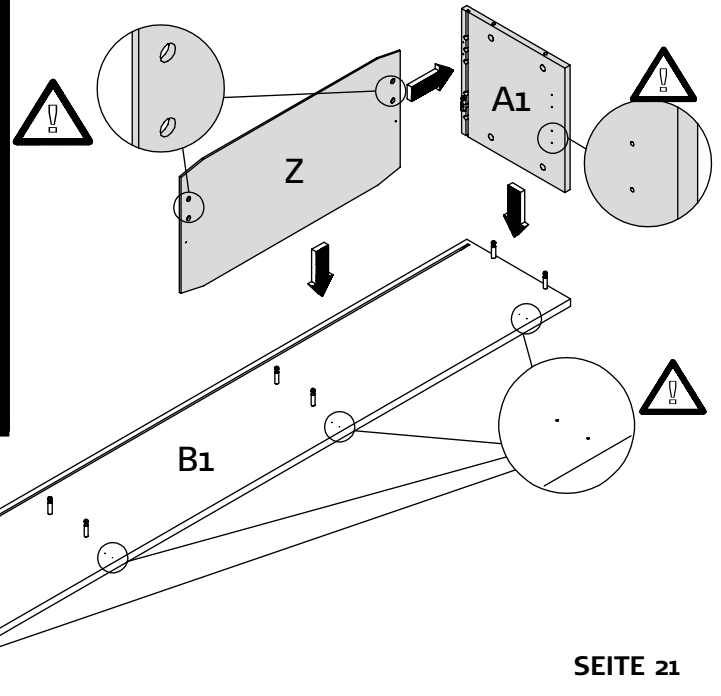

MONTAGEANLEITUNG
HÄNGEELEMENT 2R 140ER / 210ER
TYP 4381 / 4382 / 4391 / 4392 / 4481 / 4482

WALL UNIT 2 R, 140/210 CM WIDE
ELEMENT SUSPENDU 2U, 140/210 CM DE LARGE
HANGELEMENT 2 R, 140/210 CM BREED

now!
by hülsta

no.7

MONTAGE · ASSEMBLY · MONTAGE · MONTAGE

5

Typ 4381, 4382, 4391, 4392

Type
Réf.
Type

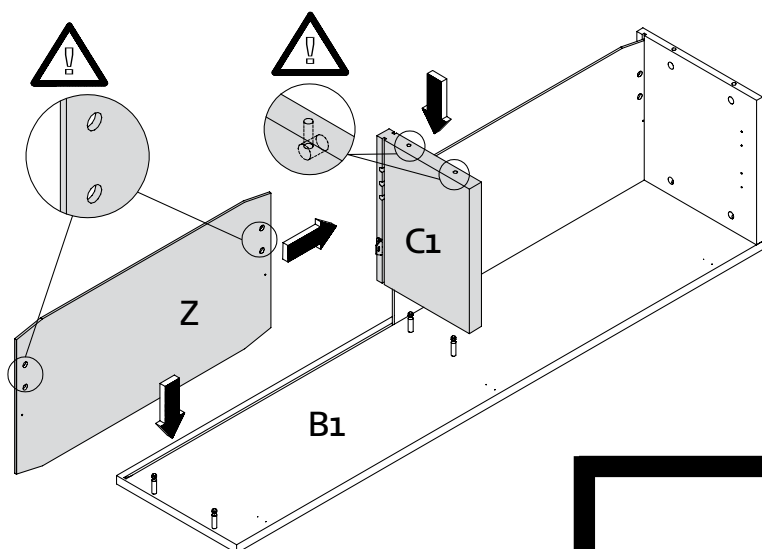

5

Typ 4481, 4482

Type
Réf.
Type

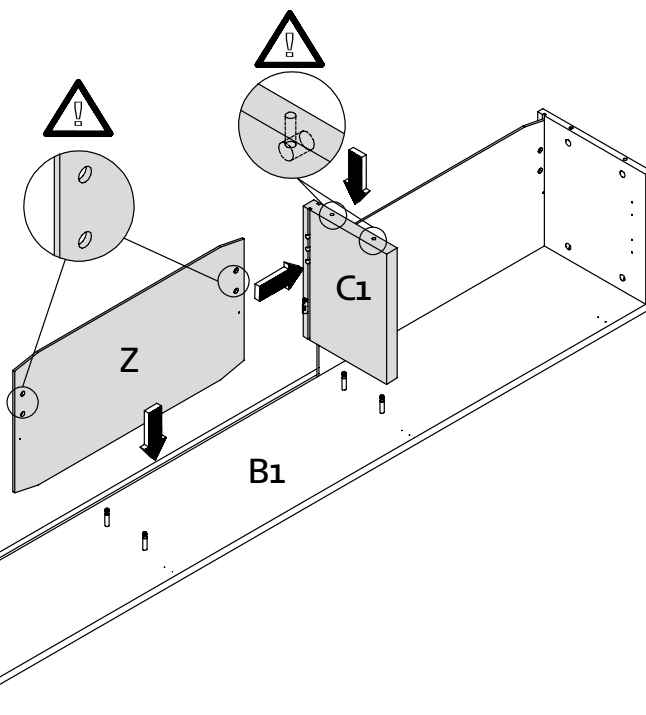

6

Typ 4481, 4482

Type
Réf.
Type

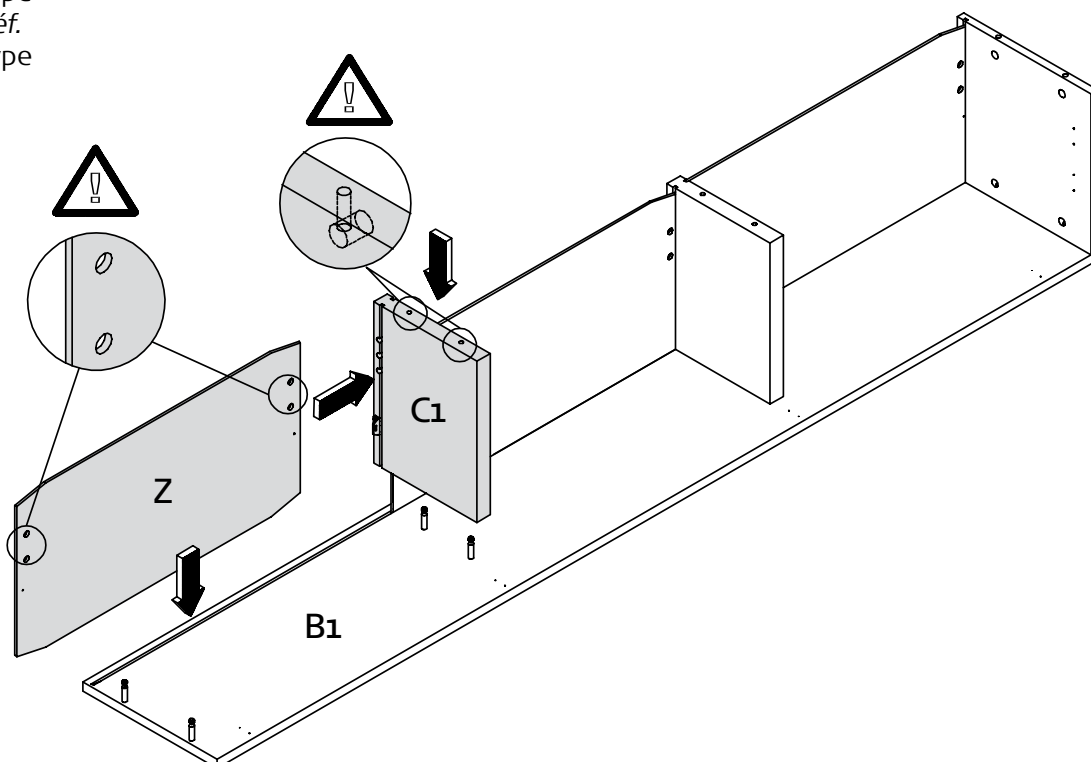

MONTAGEANLEITUNG
HÄNGEELEMENT 2R 140ER / 210ER
TYP 4381 / 4382 / 4391 / 4392 / 4481 / 4482



WALL UNIT 2 R, 140/210 CM WIDE
ELEMENT SUSPENDU 2U, 140/210 CM DE LARGE
HANGELEMENT 2 R, 140/210 CM BREED

MONTAGE · ASSEMBLY · MONTAGE · MONTAGE

7

Typ 4381, 4382, 4391, 4392

Type
Réf.
Type

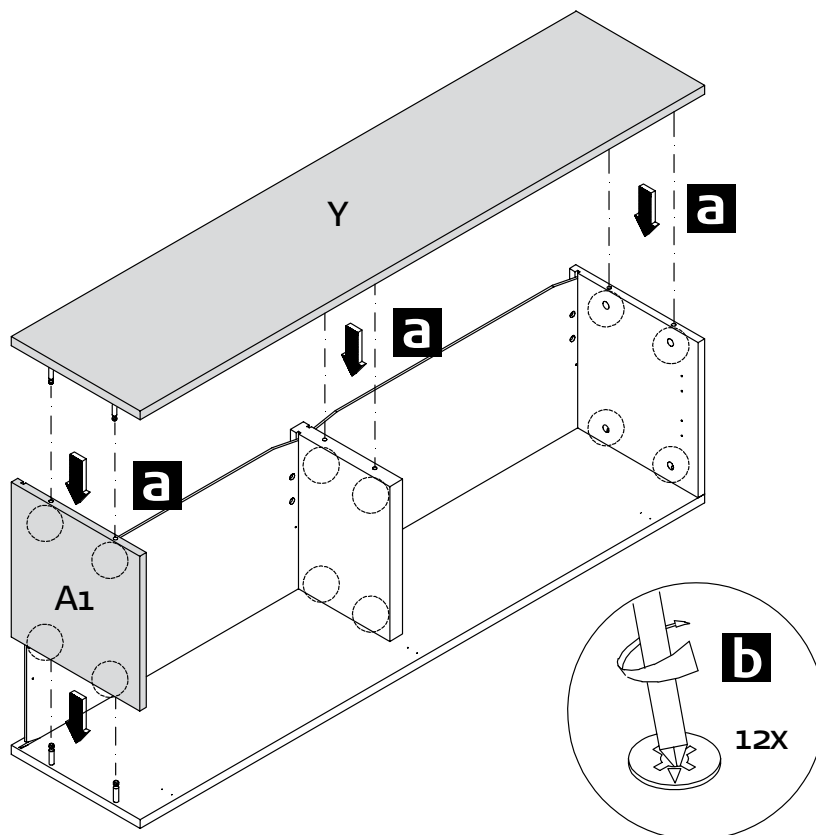

7

Typ 4481, 4482

Type
Réf.
Type

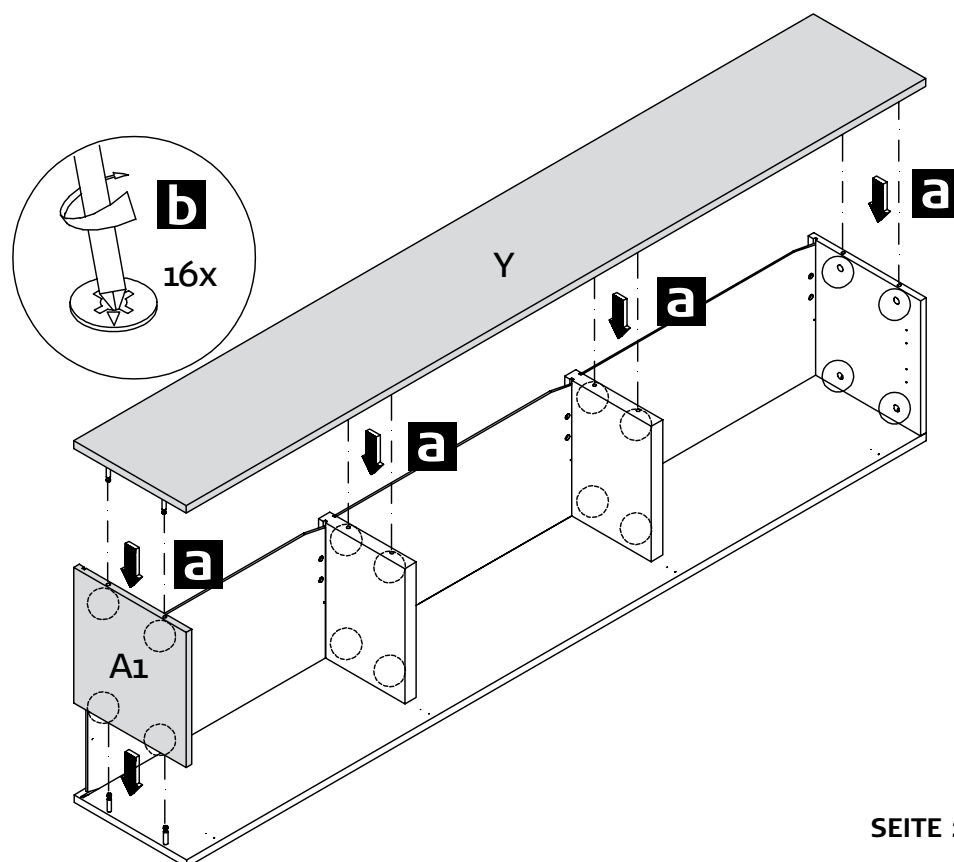

MONTAGEANLEITUNG
HÄNGEELEMENT 2R 140ER / 210ER
 TYP 4381 / 4382 / 4391 / 4392 / 4481 / 4482



WALL UNIT 2 R, 140/210 CM WIDE
 ELEMENT SUSPENDU 2U, 140/210 CM DE LARGE
 HANGELEMENT 2 R, 140/210 CM BREED

MONTAGE · ASSEMBLY · MONTAGE · MONTAGE

8 Typ 4381, 4382, 4391, 4392
 Type
 Réf.
 Type

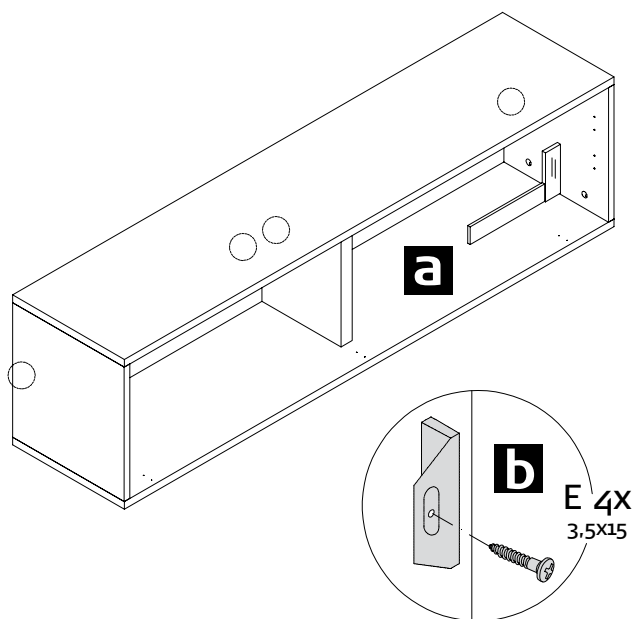

8 Typ 4481, 4482
 Type
 Réf.
 Type

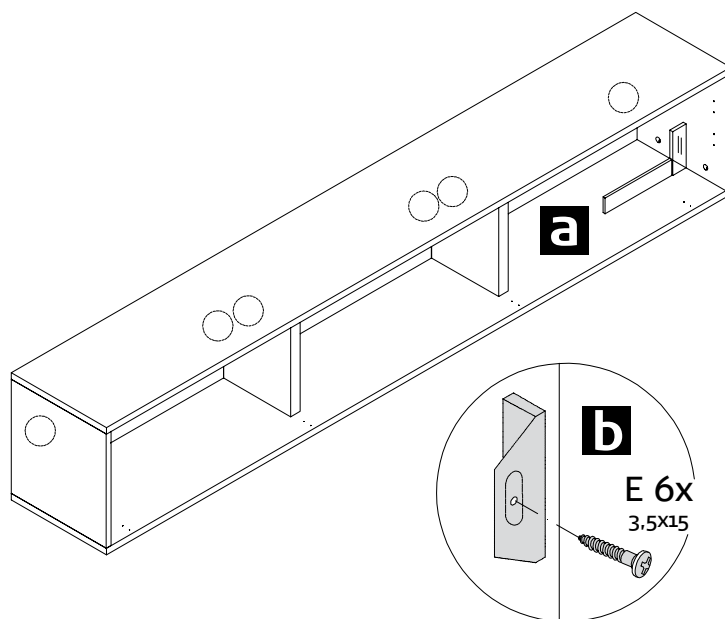

9 Typ 4381, 4382, 4391, 4392
 Type
 Réf.
 Type

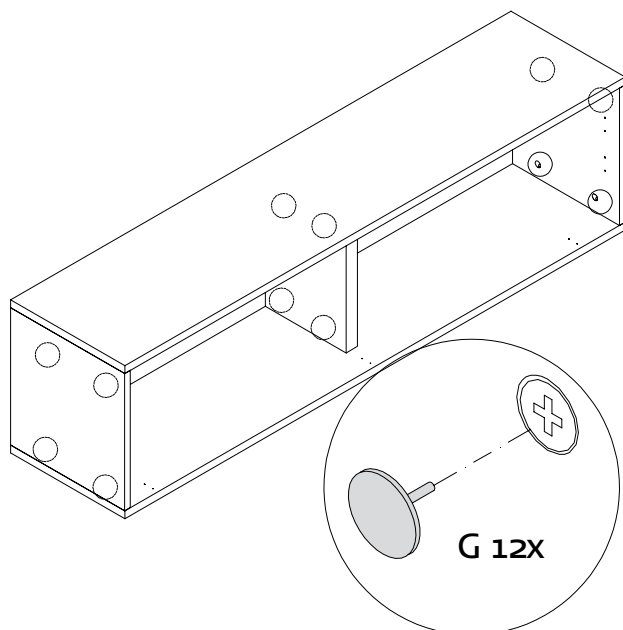

9 Typ 4481, 4482
 Type
 Réf.
 Type

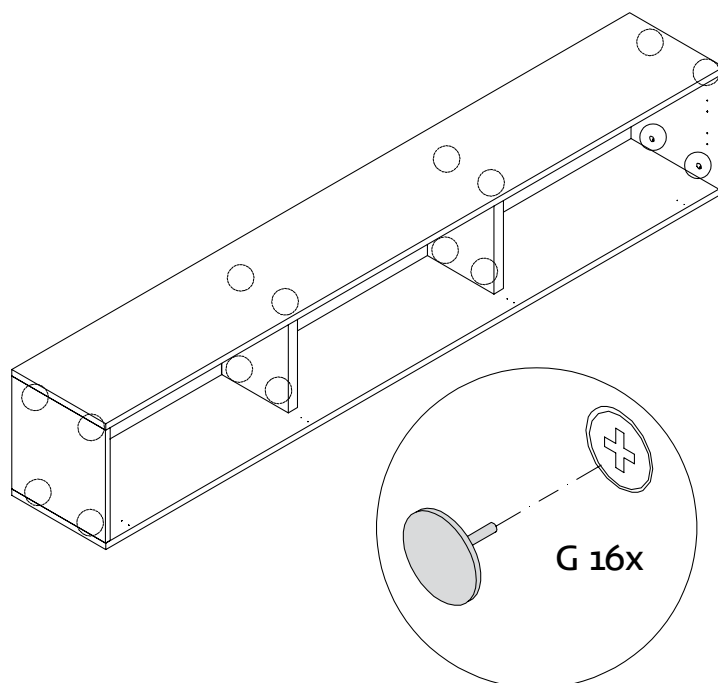

MONTAGEANLEITUNG
HÄNGEELEMENT 2R 140ER / 210ER - HOLZKLAPPE
 TYP 4381 / 4382 / 4481 / 4482



WALL UNIT 2 R, 140/210 CM WIDE - WOODEN FLAP
 ELEMENT SUSPENDU 2U, 140/210 CM DE LARGE - ABATTANT EN BOIS
 HANGLEMENT 2 R, 140/210 CM BREED - HOUTEN KLEP

MONTAGE · ASSEMBLY · MONTAGE · MONTAGE

10

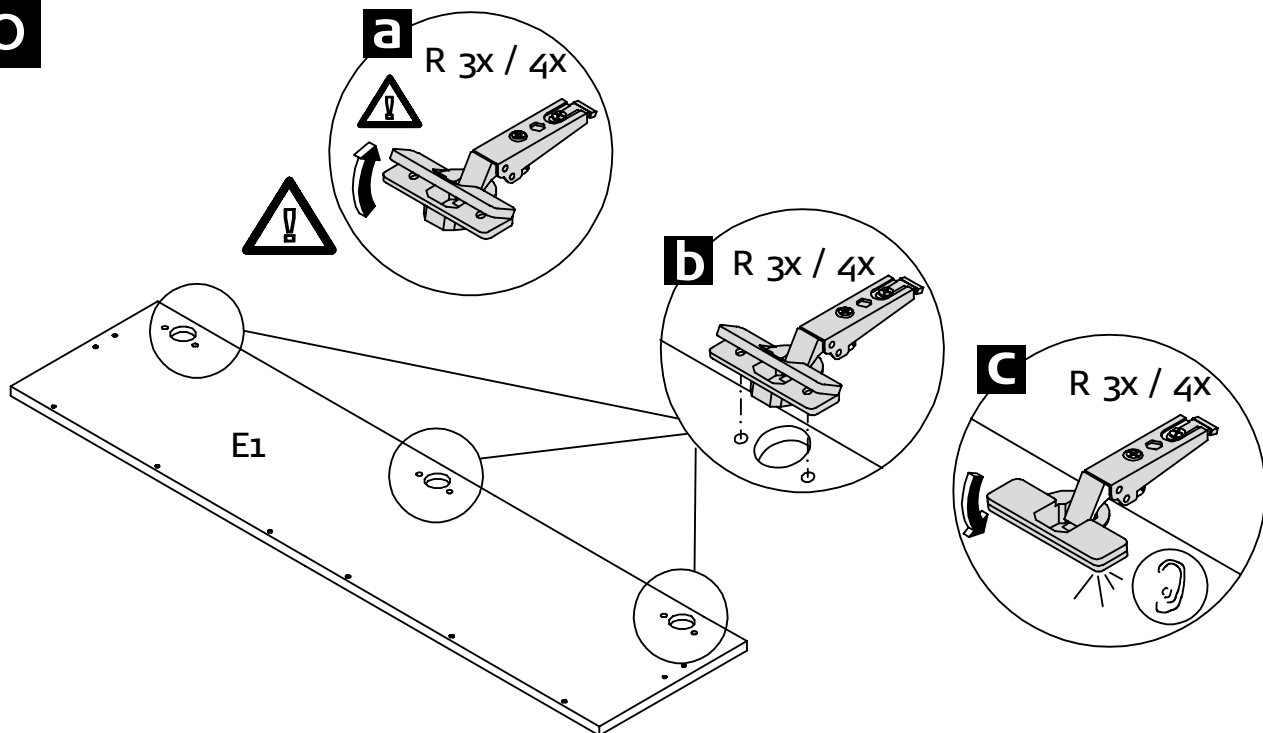

11

Typ 4381, 4382, 4391, 4392
 Type
 Réf.
 Type

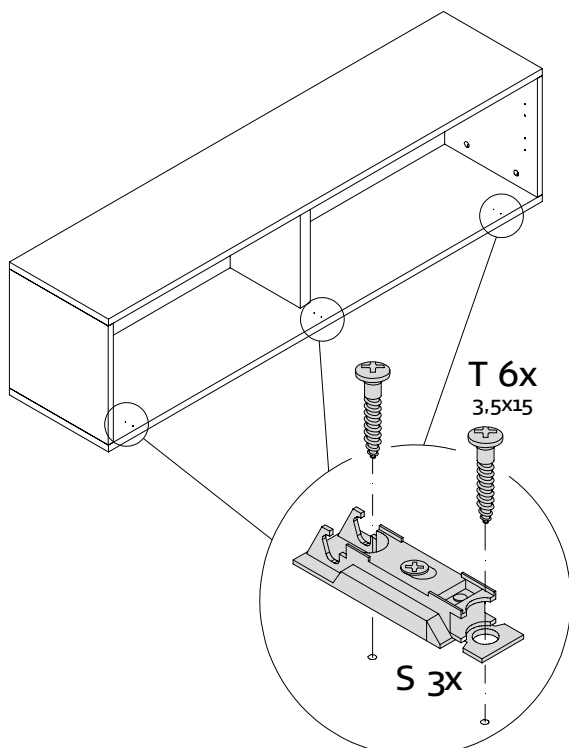

11

Typ 4481, 4482
 Type
 Réf.
 Type

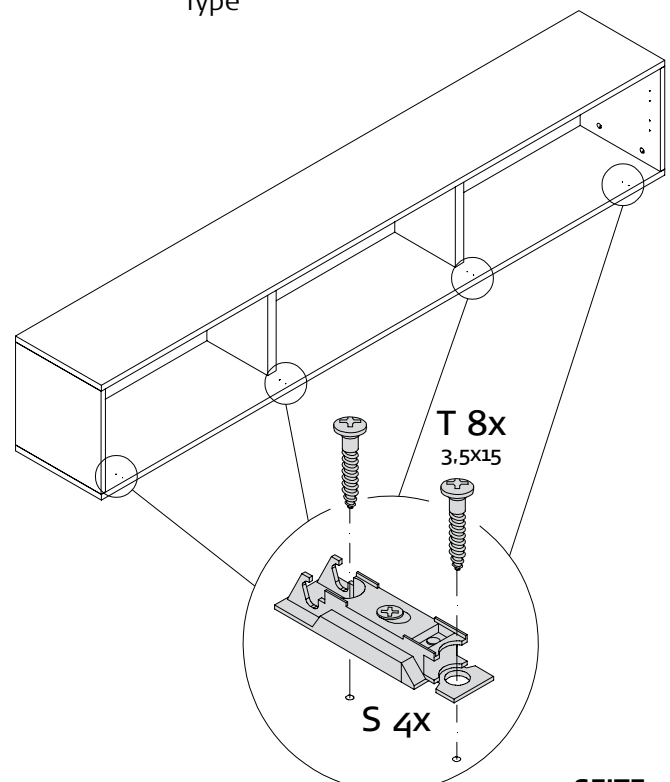

MONTAGEANLEITUNG HÄNGEELEMENT 2R 140ER / 210ER - HOLZKLAPPE

TYP 4381 / 4382 / 4481 / 4482

WALL UNIT 2 R, 140/210 CM WIDE - WOODEN FLAP
ELEMENT SUSPENDU 2U, 140/210 CM DE LARGE - ABATTANT EN BOIS
HANGELEMENT 2 R, 140/210 CM BREED - HOUTEN KLEP

now!
by hülsta

no.7

MONTAGE · ASSEMBLY · MONTAGE · MONTAGE

12

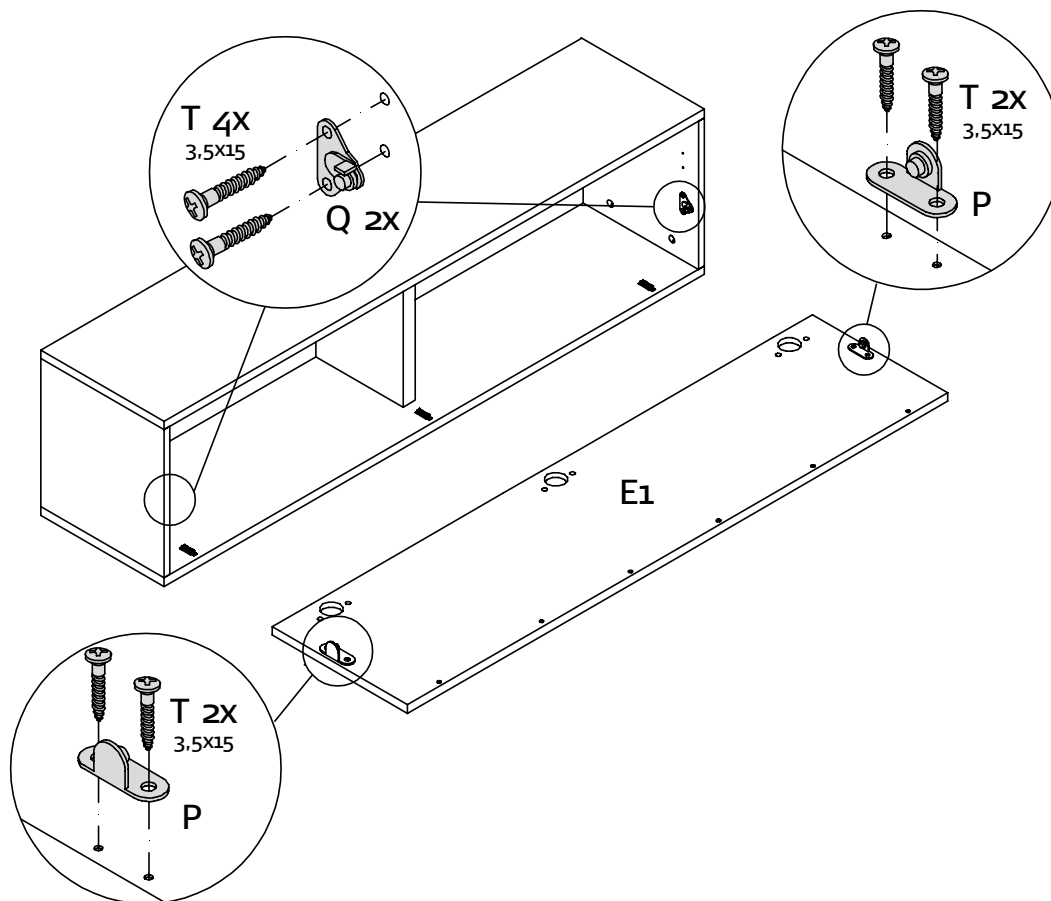

13

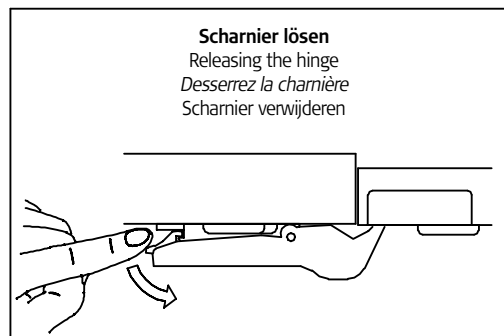
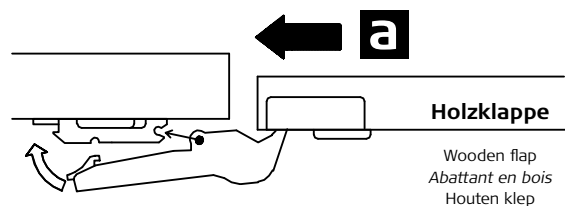
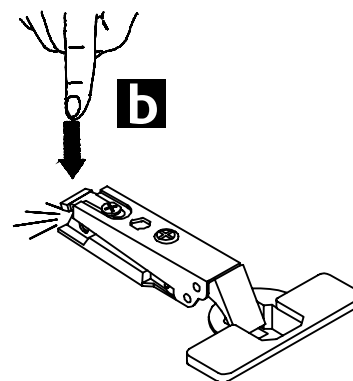
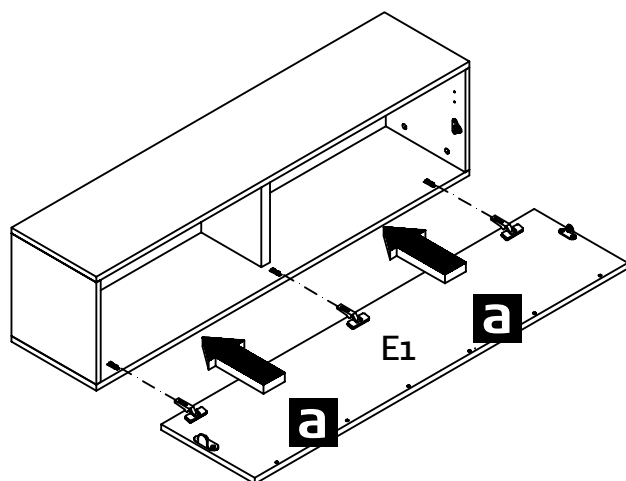

Scharnier lösen
Releasing the hinge
Desserrez la charnière
Scharnier verwijderen

MONTAGEANLEITUNG
HÄNGEELEMENT 2R 140ER / 210ER - HOLZKLAPPE
 TYP 4381 / 4382 / 4481 / 4482

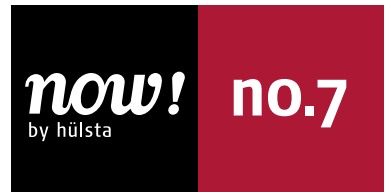

WALL UNIT 2 R, 140/210 CM WIDE - WOODEN FLAP
 ELEMENT SUSPENDU 2U, 140/210 CM DE LARGE - ABATTANT EN BOIS
 HANGELEMENT 2 R, 140/210 CM BREED - HOUTEN KLEP

MONTAGE · ASSEMBLY · MONTAGE · MONTAGE

14

Falsch!
 Wrong!
 Incorrect!
 Fout!



Richtig!
 Correct!
 Correct!
 Correct!

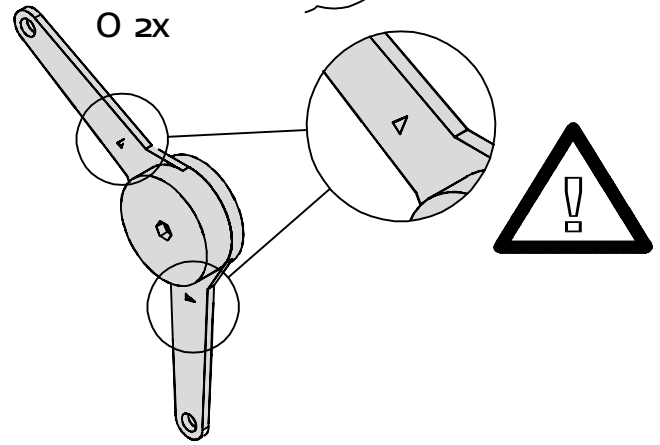
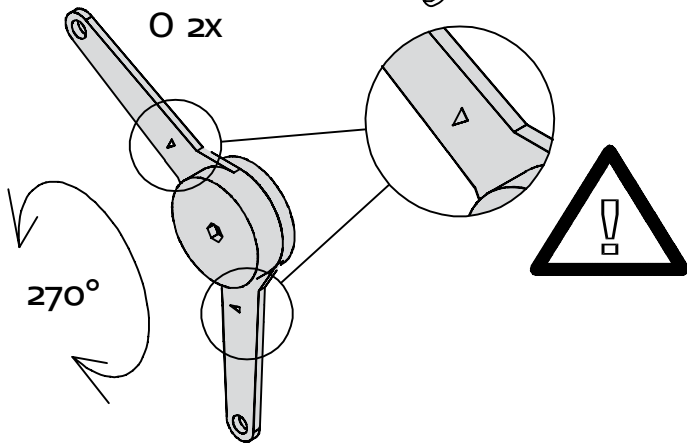

15

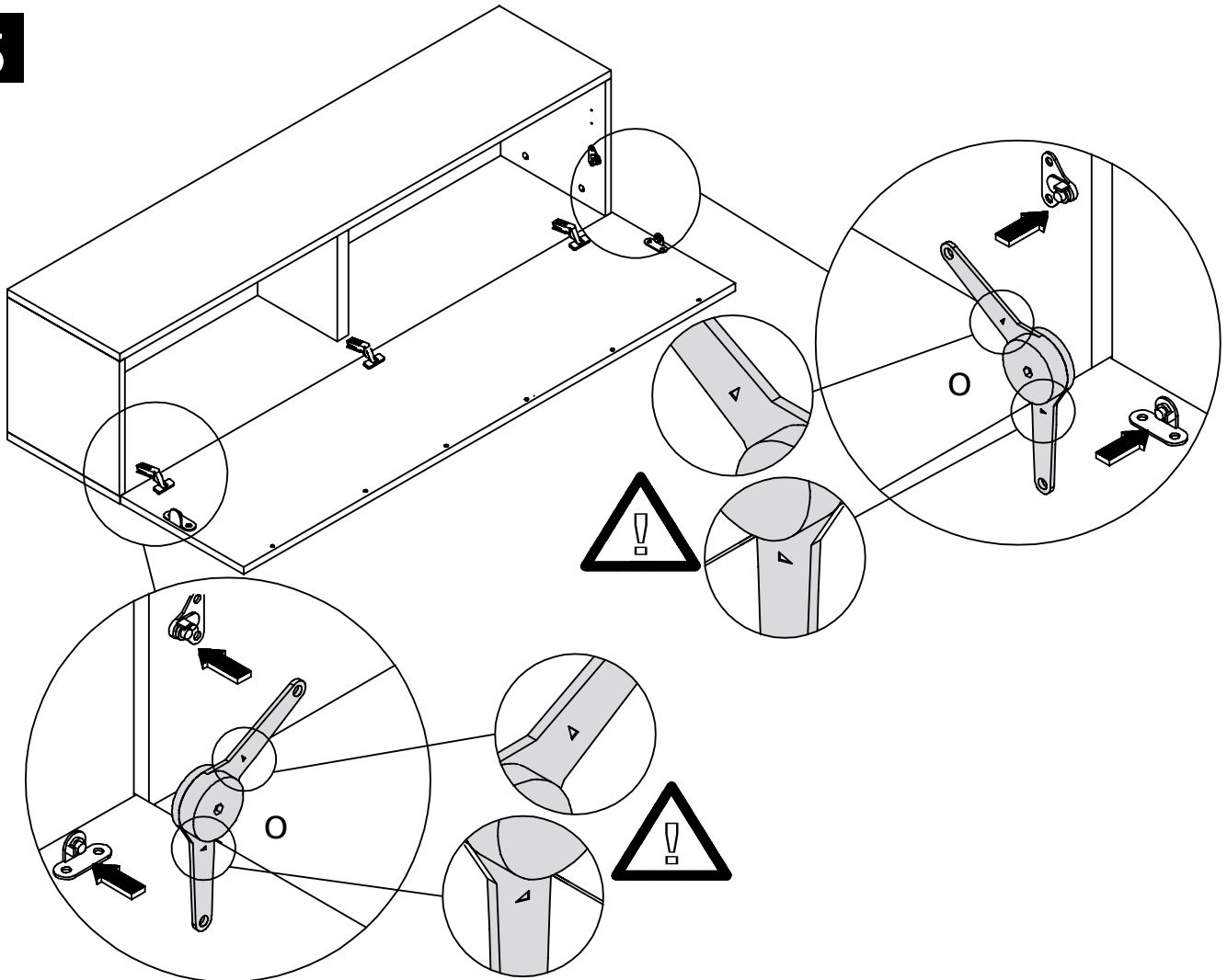

MONTAGEANLEITUNG
HÄNGEELEMENT 2R 140ER / 210ER - HOLZKLAPPE
 TYP 4381 / 4382 / 4481 / 4482

WALL UNIT 2 R, 140/210 CM WIDE - WOODEN FLAP
 ELEMENT SUSPENDU 2U, 140/210 CM DE LARGE - ABATTANT EN BOIS
 HANGELEMENT 2 R, 140/210 CM BREED - HOUTEN KLEP

now!
 by hülsta

no.7

MONTAGE · ASSEMBLY · MONTAGE · MONTAGE

16

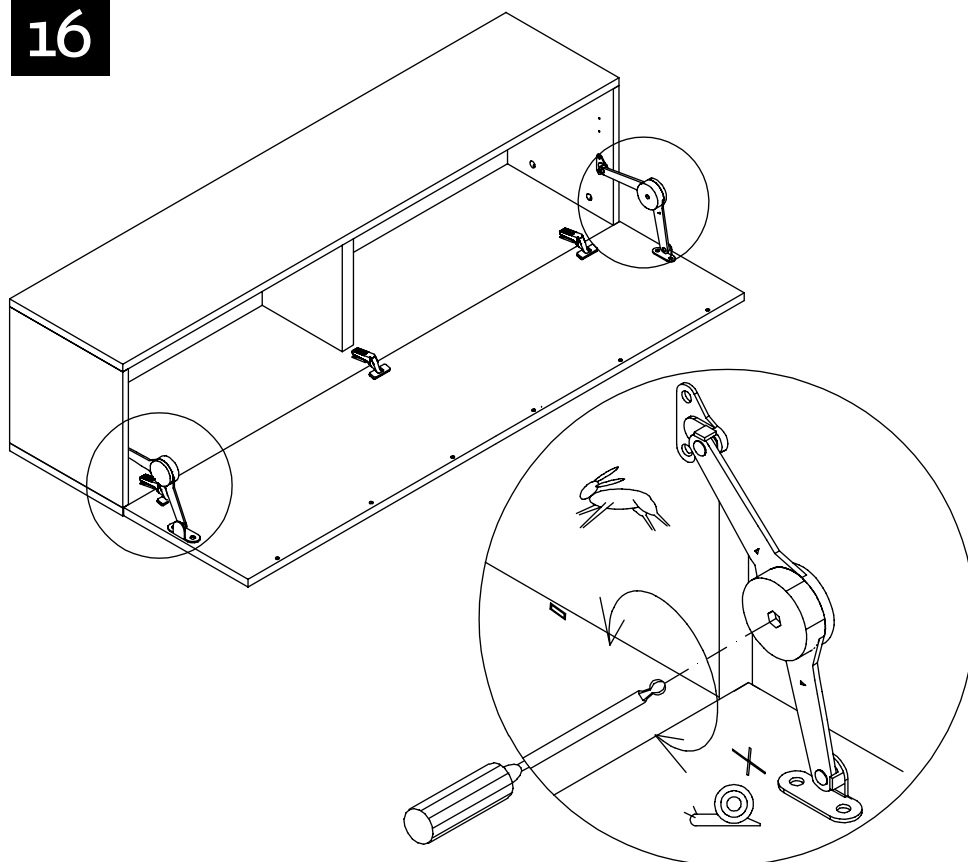

17

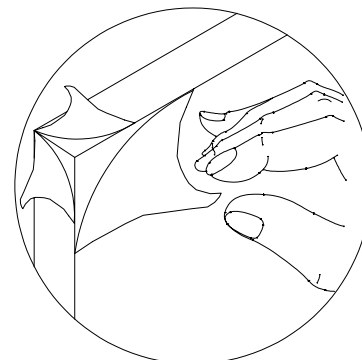

Schutzfolie abziehen!

Remove protective foil!
 Enlever feuille de protection!
 Beschermingsfolie aftrekken!

18

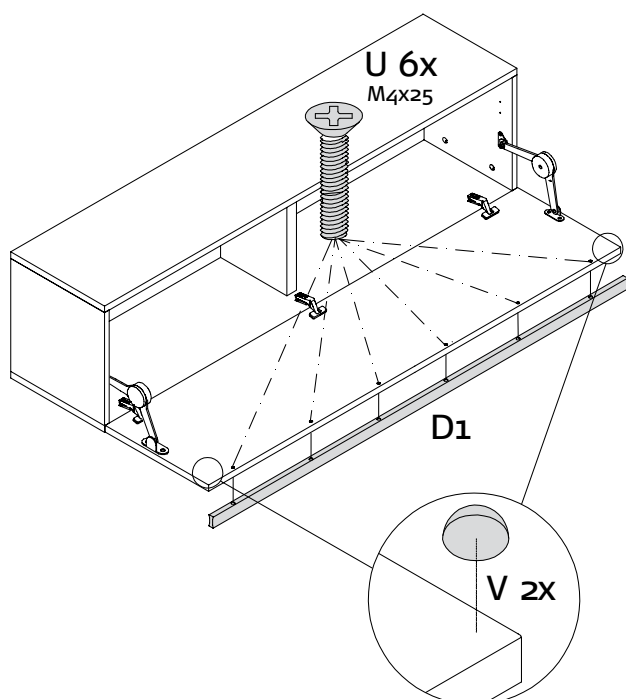

19

Scharniverstellung
 Adjustment of hinge
 Ajustage de la charnière
 Afhangen van het scharnier

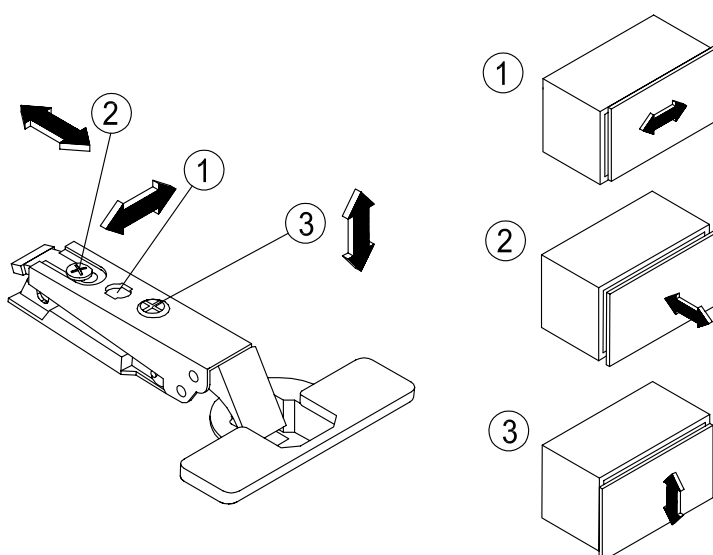

MONTAGEANLEITUNG

HÄNGEELEMENT 2R 140ER / 210ER - GLASKLAPPE

TYP 4391 / 4392

now!
by hülsta

no.7

WALL UNIT 2 R, 140/210 CM WIDE - GLASS FLAP
ELEMENT SUSPENDU 2U, 140/210 CM DE LARGE - ABATTANT EN VERRE
HANGELEMENT 2 R, 140/210 CM BREED - GLASKLEP

MONTAGE · ASSEMBLY · MONTAGE · MONTAGE

10

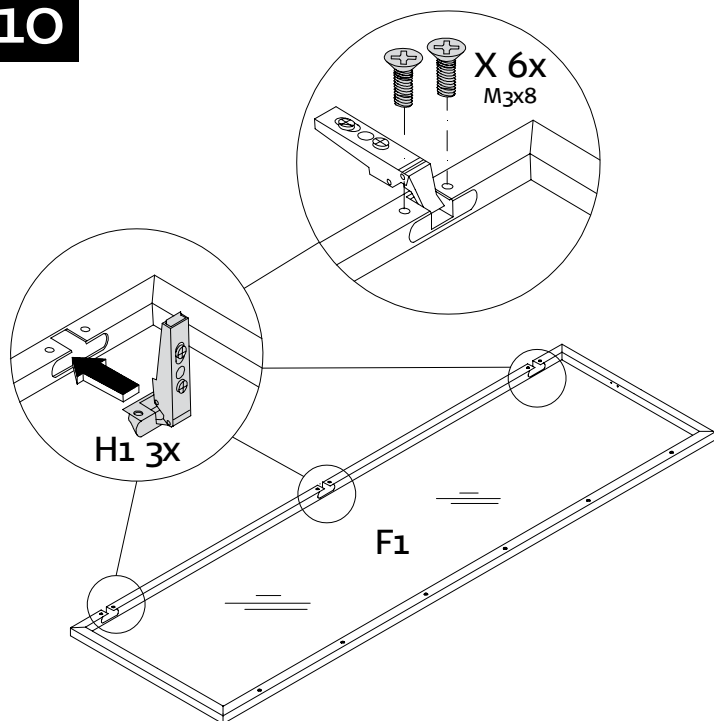

11

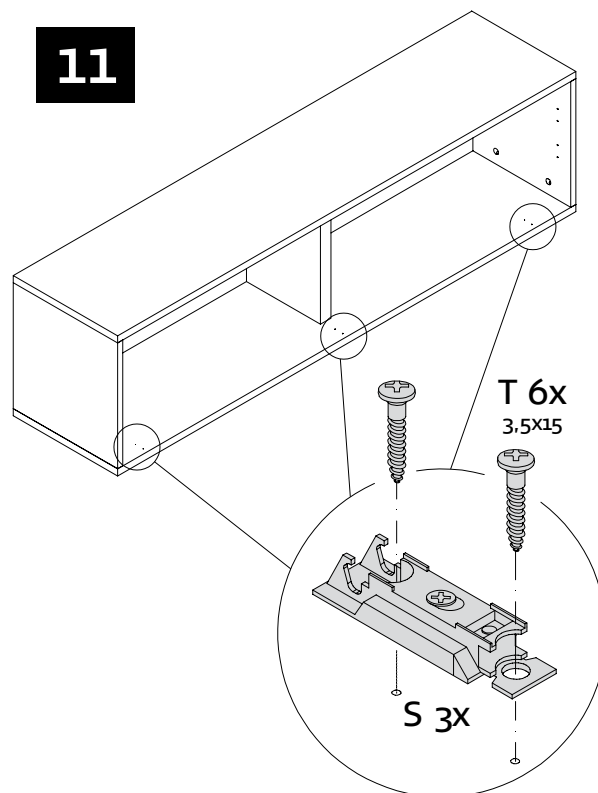

12

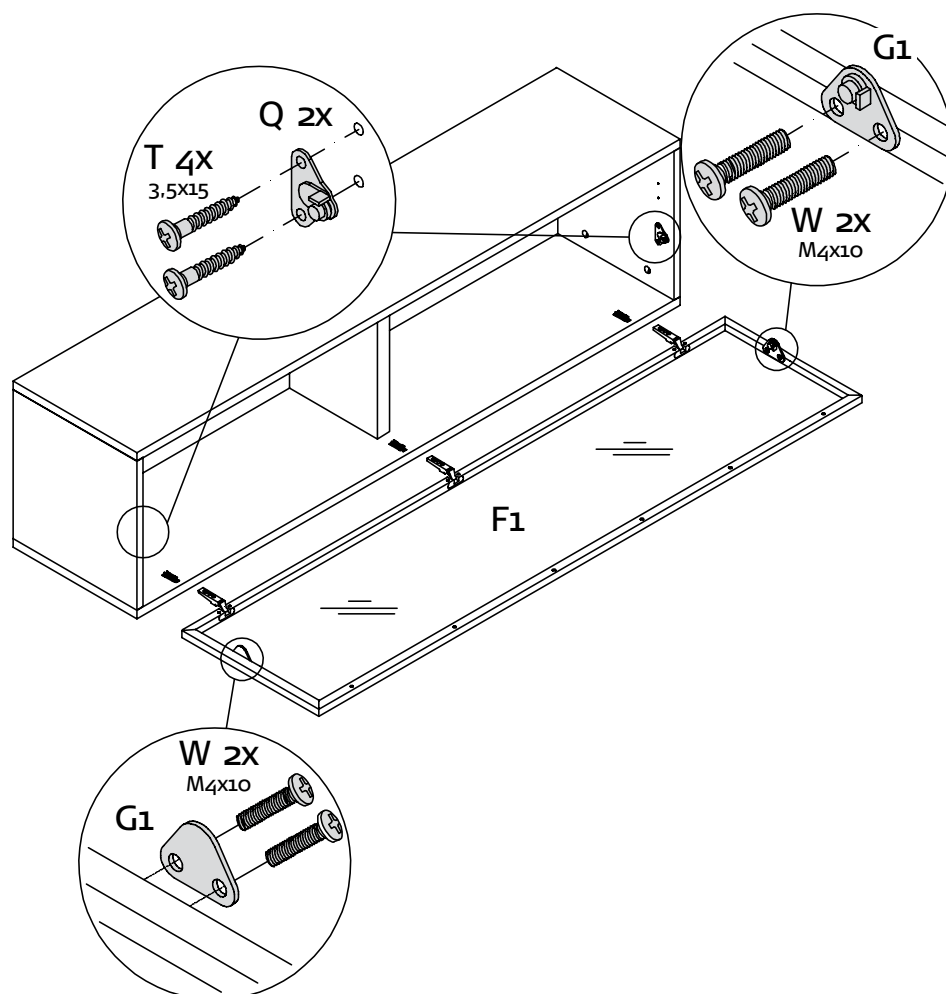

MONTAGEANLEITUNG
HÄNGEELEMENT 2R 140ER / 210ER - GLASKLAPPE
 TYP 4391 / 4392



WALL UNIT 2 R, 140/210 CM WIDE - GLASS FLAP
 ELEMENT SUSPENDU 2U, 140/210 CM DE LARGE - ABATTANT EN VERRE
 HANGELEMENT 2 R, 140/210 CM BREED - GLASKLEP

MONTAGE · ASSEMBLY · MONTAGE · MONTAGE

13

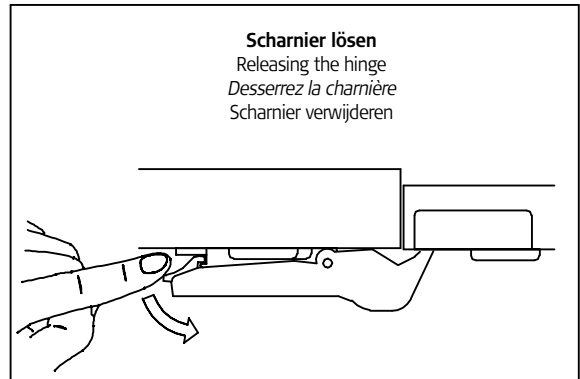
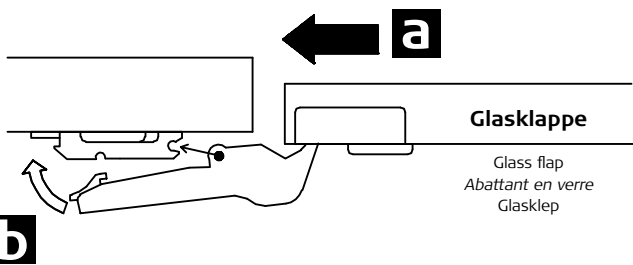
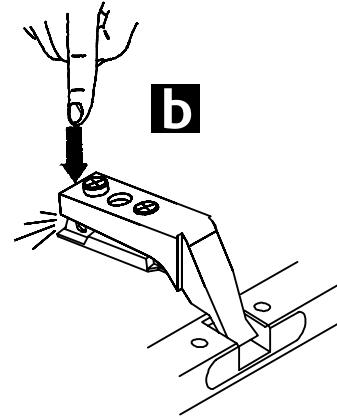
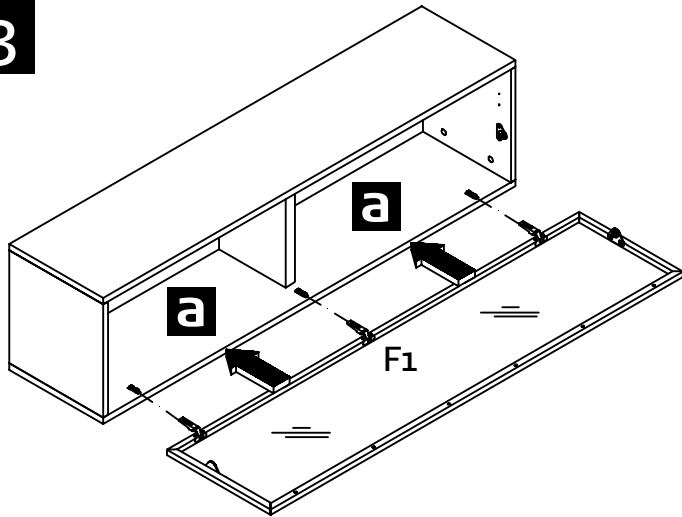

14

Falsch!
 Wrong!
 Incorrect!
 Fout!

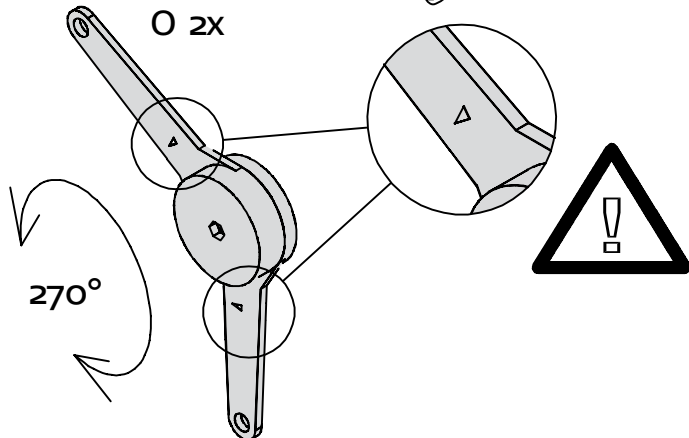

Richtig!
 Correct!
 Correct!
 Correct!

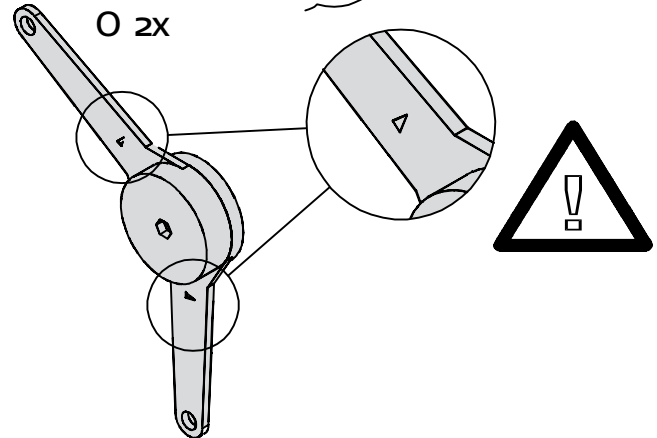

MONTAGEANLEITUNG
HÄNGEELEMENT 2R 140ER / 210ER - GLASKLAPPE
TYP 4391 / 4392



WALL UNIT 2 R, 140/210 CM WIDE - GLASS FLAP
ELEMENT SUSPENDU 2U, 140/210 CM DE LARGE - ABATTANT EN VERRE
HÄNGEELEMENT 2 R, 140/210 CM BREED - GLASKLEP

MONTAGE · ASSEMBLY · MONTAGE · MONTAGE

15

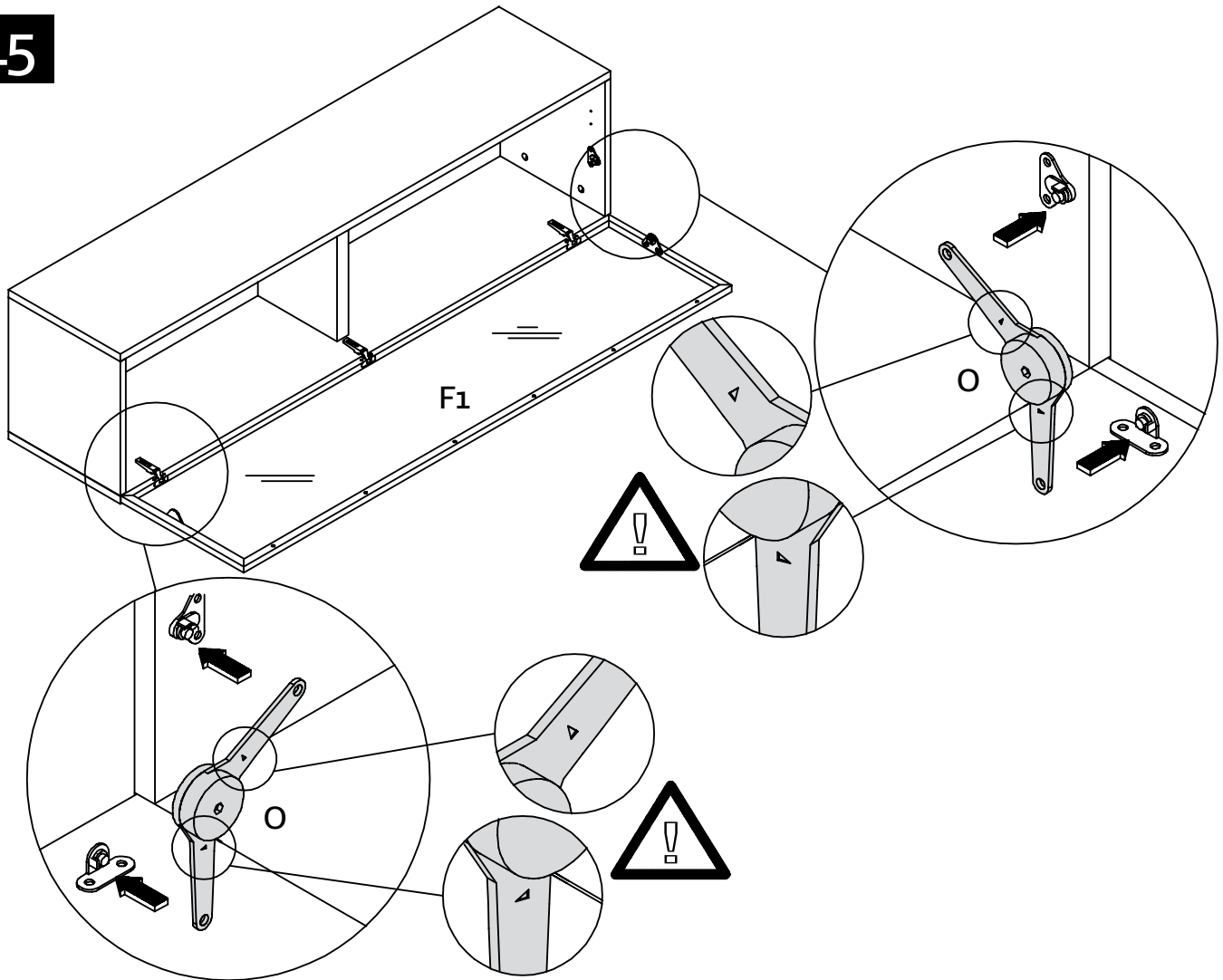

16

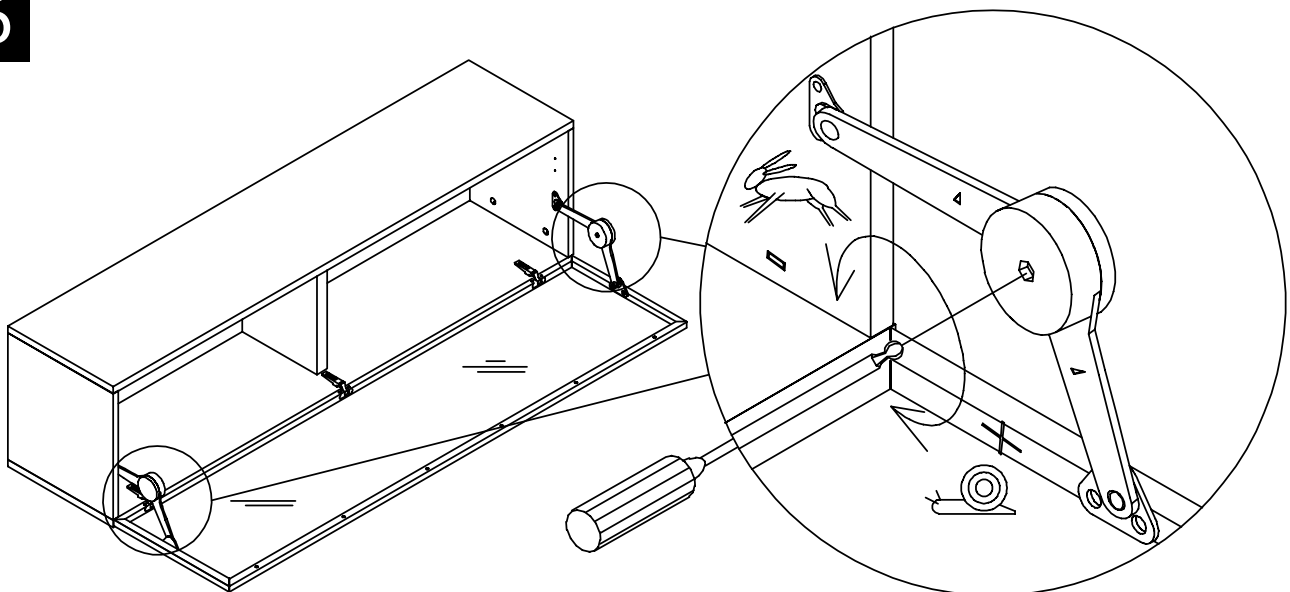

MONTAGEANLEITUNG

HÄNGEELEMENT 2R 140ER / 210ER - GLASKLAPPE

TYP 4391 / 4392

WALL UNIT 2 R, 140/210 CM WIDE - GLASS FLAP
ELEMENT SUSPENDU 2U, 140/210 CM DE LARGE - ABATTANT EN VERRE
HANGELEMENT 2 R, 140/210 CM BREED - GLASKLEP

now!
by hülsta

no.7

MONTAGE · ASSEMBLY · MONTAGE · MONTAGE

17

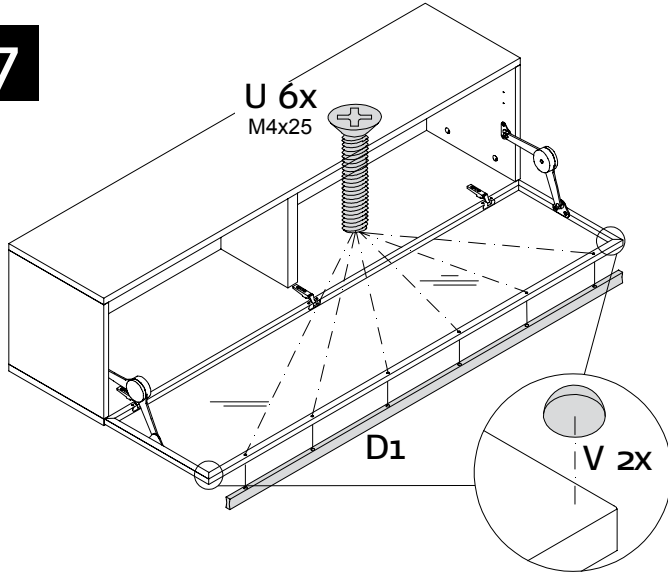

18

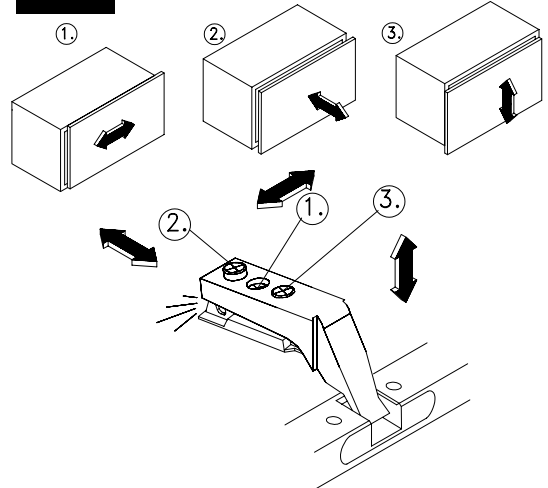

MONTAGEANLEITUNG

HÄNGEELEMENT 2R 140ER / 210ER - AUFHÄNGUNG

TYP 4381 / 4382 / 4391 / 4392 / 4481 / 4482

WALL UNIT 2 R, 140/210 CM WIDE - WALL ASSEMBLY
ELEMENT SUSPENDU 2U, 140/210 CM DE LARGE - FIXATION MURALE
HANGELEMENT 2 R, 140/210 CM BREED - WANDBEVESTIGING

1

Typ 4381, 4382, 4391, 4392

Type
Réf.
Type

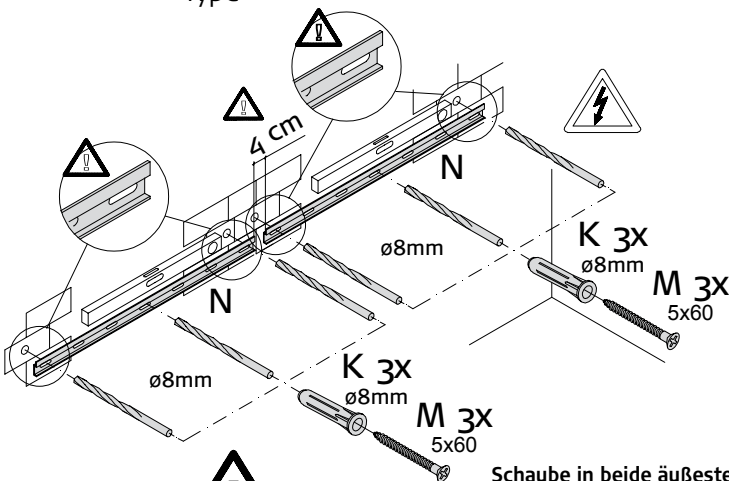

Gefahr bei fehlerhafter Montage!
Danger if not properly fitted!
Danger lors d'un montage incorrect!
Attentie! Een verkeerde montage kan gevaarlijk zijn!

Schraube in beide äußesten und im mittigen Langloch gefestigen!
Fix screws in both outer holes and in long central hole.
Fixer les vis dans les deux trous oblongs des extrémités et celui du centre.
Schroeven in beide buitenste en middelste sleufgat bevestigen

Wandbefestigung

Achtung! Die Wandbeschaffenheit ist vor der Montage unbedingt zu prüfen. Verwendung von Dübeln bei Beton und/oder festem Mauerwerk. Bei abweichender Beschaffenheit (z.B. Rahmenbauweise mit Gipskartonplatten, Leichtbausteinen etc.) ist eine andere, der Belastung angemessene Befestigung bauseits vorzunehmen. Beachten Sie, dass in dem Befestigungsbereich keine Elektro-Installationszonen und keine Ver- oder Entsorgungslösungen vorhanden sein dürfen. Prüfen Sie mit einem geeigneten Leitungssuchgerät. Beachten Sie, dass Kunststoffrohre nicht dedektiert werden.

Wall mounting

Please note! Please be sure to test the soundness of walls beforehand. Use plugs for concrete and solid walls. Use a different method that is capable of withstanding the load for lighter types of walls (e.g. framed gypsum plaster board, light brickwork, etc.). Please note that there must not be any electrical installations nor any electrical connections or leads of any kind in the assembly area. Please ensure this is so by testing the area with a suitable electrical leads search device. Please also note that plastic tubing will not be detected.

Fixation murale

Attention! La composition du mur doit absolument être contrôlée. Utilisation de chevilles pour le béton et/ou la maçonnerie dure. Pour les autres types de construction (cloisons en placo-plâtre, maçonnerie légère, etc...), il faut prévoir un autre mode de fixation en rapport avec la charge. Veuillez contrôler l'absence d'installations électriques et de conduits dans le secteur de la fixation à l'aide d'un appareil. Veuillez noter que les tubes en matière synthétiques ne sont pas détectés.

Bevestiging aan de muur

Attentie! Controleer, alvorens te beginnen, altijd de aard en de kwaliteit van de muur, waaraan gemonteerd moet worden. Gebruik voor de bevestiging aan beton en schoonmetselwerk de door hülsta meegeleverde standaard pluggen en passende schroeven. In geval van muren van een ander, lichter soort materiaal (bijv. gipsplaten op een raamwerk of lichte bouwstenen) moet een ander, aan het draagvermogen aangepast speciaal bevestigingsmateriaal gebruikt worden. N.B.! In het muurgedeelte waar gemonteerd moet worden, mogen zich geen elektro-installatiezones bevinden resp. mogen geen aan- en/of afvoerleidingen (buisen) lopen. Dit kan gecontroleerd worden met speciale daarvoor bestemde detectieapparatuur. N.B.! Kunststofleidingen kunnen helaas niet worden gedetecteerd.

MONTAGEANLEITUNG

HÄNGEELEMENT 2R 140ER / 210ER - AUFHÄNGUNG

TYP 4381 / 4382 / 4391 / 4392 / 4481 / 4482

WALL UNIT 2 R, 140/210 CM WIDE - WALL ASSEMBLY
 ELEMENT SUSPENDU 2U, 140/210 CM DE LARGE - FIXATION MURALE
 HANGELEMENT 2 R, 140/210 CM BREED - WANDBEVESTIGING

now! by hülsta **no.7**

MONTAGE · ASSEMBLY · MONTAGE · MONTAGE

1

Typ 4481, 4482

Type

Réf.

Type

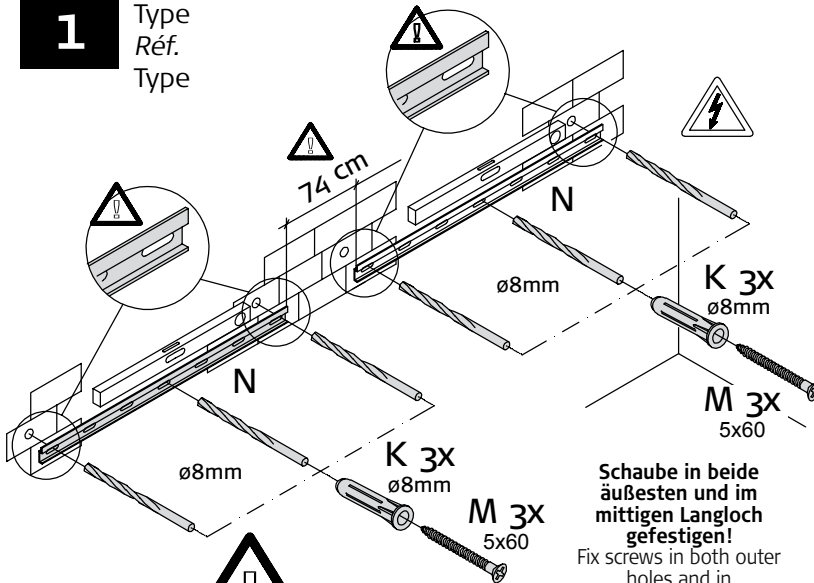

Gefahr bei fehlerhafter Montage!
 Danger if not properly fitted!
 Danger lors d'un montage incorrect!
 Attention! Een verkeerde montage kan gevaarlijk zijn!

Schraube in beide äußesten und im mittigen Langloch gefestigen!
 Fix screws in both outer holes and in long central hole.
 Fixer les vis dans les deux trous oblongs des extrémités et celui du centre.
 Schroeven in beide buitenste en middelste sleufgat bevestigen

Wandbefestigung

Achtung! Die Wandbeschaffenheit ist vor der Montage unbedingt zu prüfen. Verwendung von Dübeln bei Beton und/oder festem Mauerwerk. Bei abweichender Beschaffenheit (z.B. Rahmenbauweise mit Gipskartonplatten, Leichtbausteinen etc.) ist eine andere, der Belastung angemessene Befestigung bau-seits vorzunehmen. Beachten Sie, dass in dem Befestigungsbereich keine Elektro-Installationszonen und keine Ver- oder Entsorgungsleitungen vorhanden sein dürfen. Prüfen Sie mit einem geeigneten Leitungssuchgerät. Beachten Sie, dass Kunststoffrohre nicht dedektiert werden.

Wall mounting

Please note! Please be sure to test the soundness of walls beforehand. Use plugs for concrete and solid walls. Use a different method that is capable of withstanding the load for lighter types of walls (e.g. framed gypsum plaster board, light brickwork, etc.). Please note that there must not be any electrical installations nor any electrical connections or leads of any kind in the assembly area. Please ensure this is so by testing the area with a suitable electrical leads search device. Please also note that plastic tubing will not be detected.

Fixation murale

Attention! La composition du mur doit absolument être contrôlée. Utilisation de chevilles pour le béton et/ou la maçonnerie dure. Pour les autres types de construction (cloisons en placoplâtre, maçonnerie légère, etc...), il faut prévoir un autre mode de fixation en rapport avec la charge. Veuillez contrôler l'absence d'installations électriques et de conduits dans le secteur de la fixation à l'aide d'un appareil. Veuillez noter que les tubes en matière synthétiques ne sont pas détectés.

Bevestiging aan de muur

Attentie! Controleer, alvorens te beginnen, altijd de aard en de kwaliteit van de muur, waaraan gemonteerd moet worden. Gebruik voor de bevestiging aan beton en schoon metselwerk de door hülsta meegeleverde standaard pluggen en passende schroeven. In geval van muren van een ander, lichter soort materiaal (bijv. gipsplaten op een raamwerk of lichte bouwstenen) moet een ander, aan het draagvermogen aangepast speciaal bevestigingsmateriaal gebruikt worden. N.B.! In het muurgedeelte waar gemonteerd moet worden, mogen zich geen elektro-installatiezones bevinden resp. mogen geen aan- en/of afvoerleidingen (buizen) lopen. Dit kan gecontroleerd worden met speciale daarvoor bestemde detectieapparatuur. N.B.! Kunststoffleidingen kunnen helaas niet worden gedetecteerd.

2

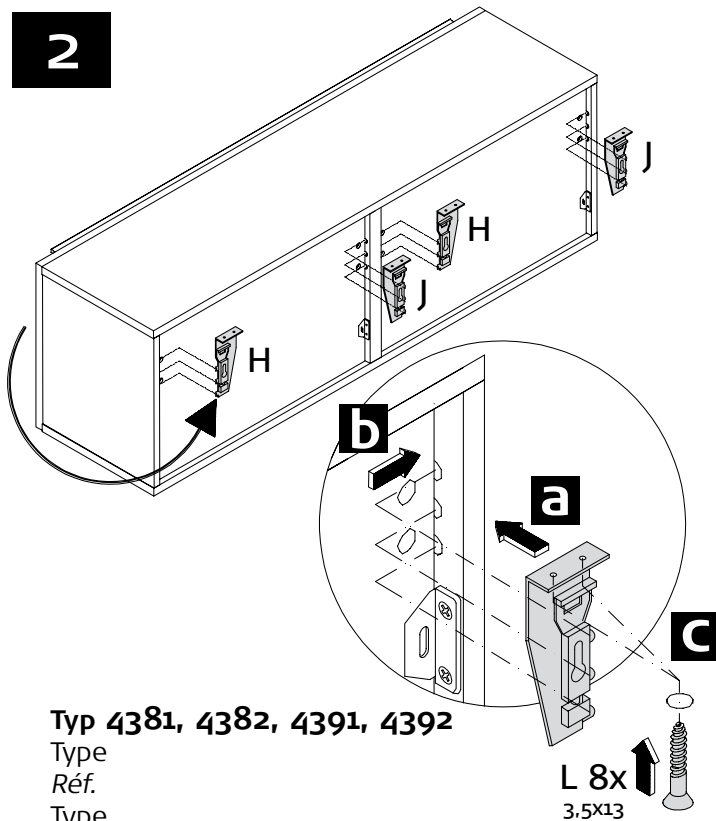

Typ 4381, 4382, 4391, 4392

Type

Réf.

Type

L 8x
3.5x13

2

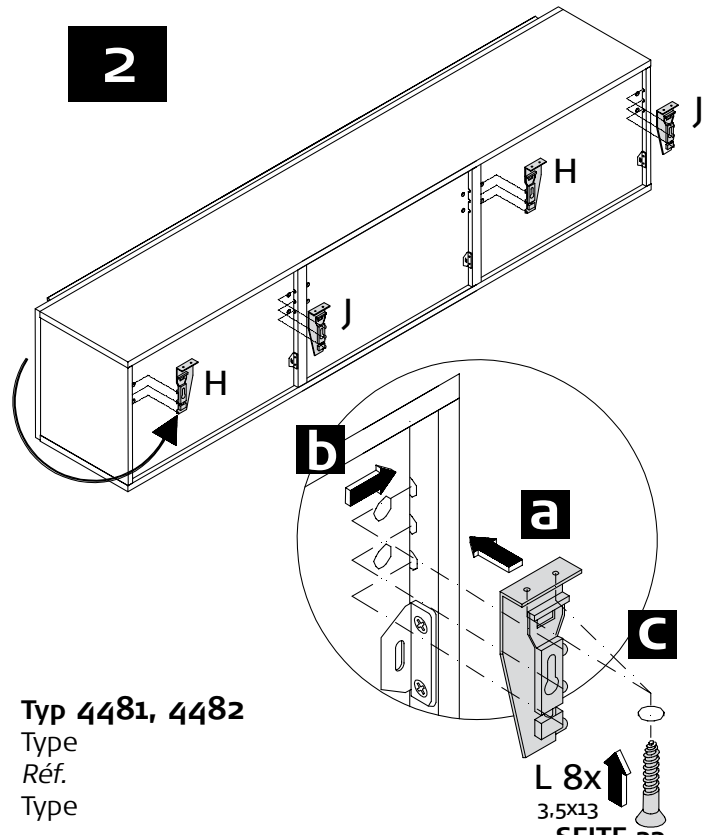

Typ 4481, 4482

Type

Réf.

Type

L 8x
3.5x13
SEITE 33

MONTAGEANLEITUNG
HÄNGEELEMENT 2R 140ER / 210ER - AUFHÄNGUNG
 TYP 4381 / 4382 / 4391 / 4392 / 4481 / 4482

now!
 by hülsta

no.7

WALL UNIT 2 R, 140/210 CM WIDE - WALL ASSEMBLY
 ELEMENT SUSPENDU 2U, 140/210 CM DE LARGE - FIXATION MURALE
 HANGELEMENT 2 R, 140/210 CM BREED - WANDBEVESTIGING

MONTAGE · ASSEMBLY · MONTAGE · MONTAGE

3

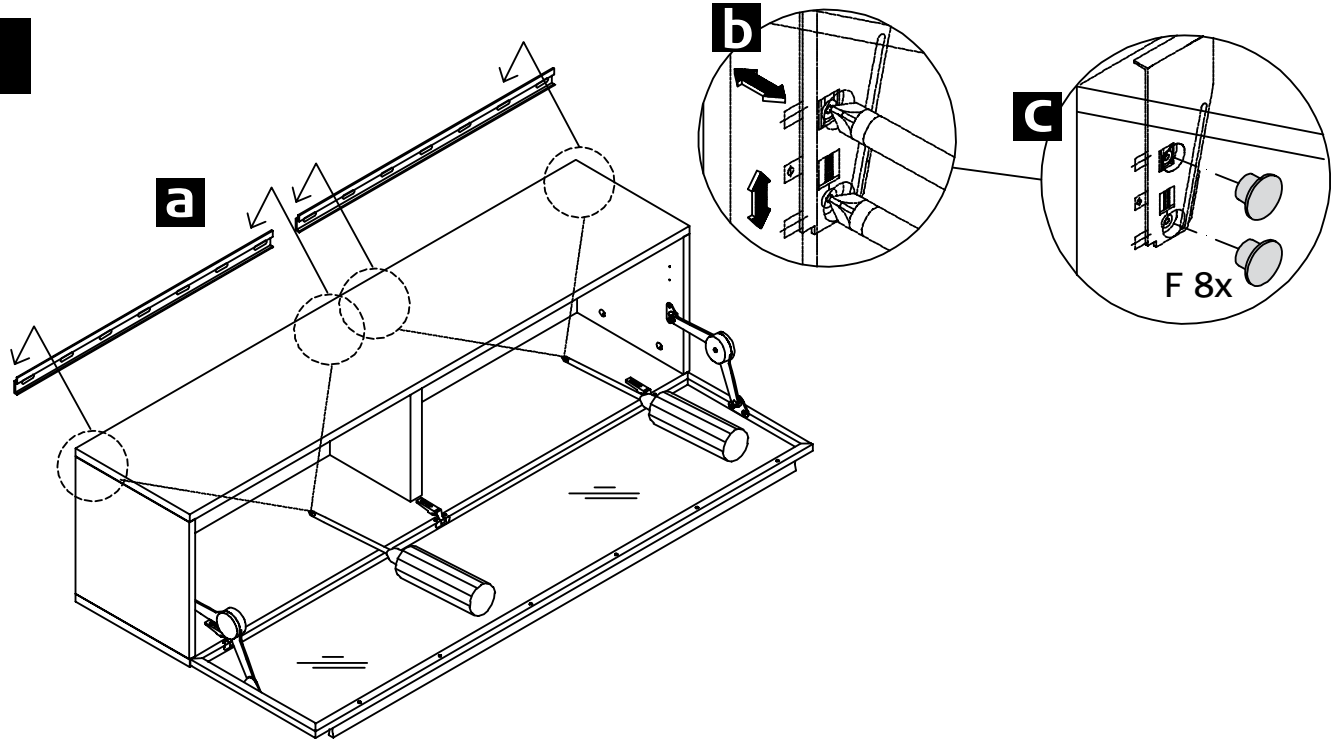

3

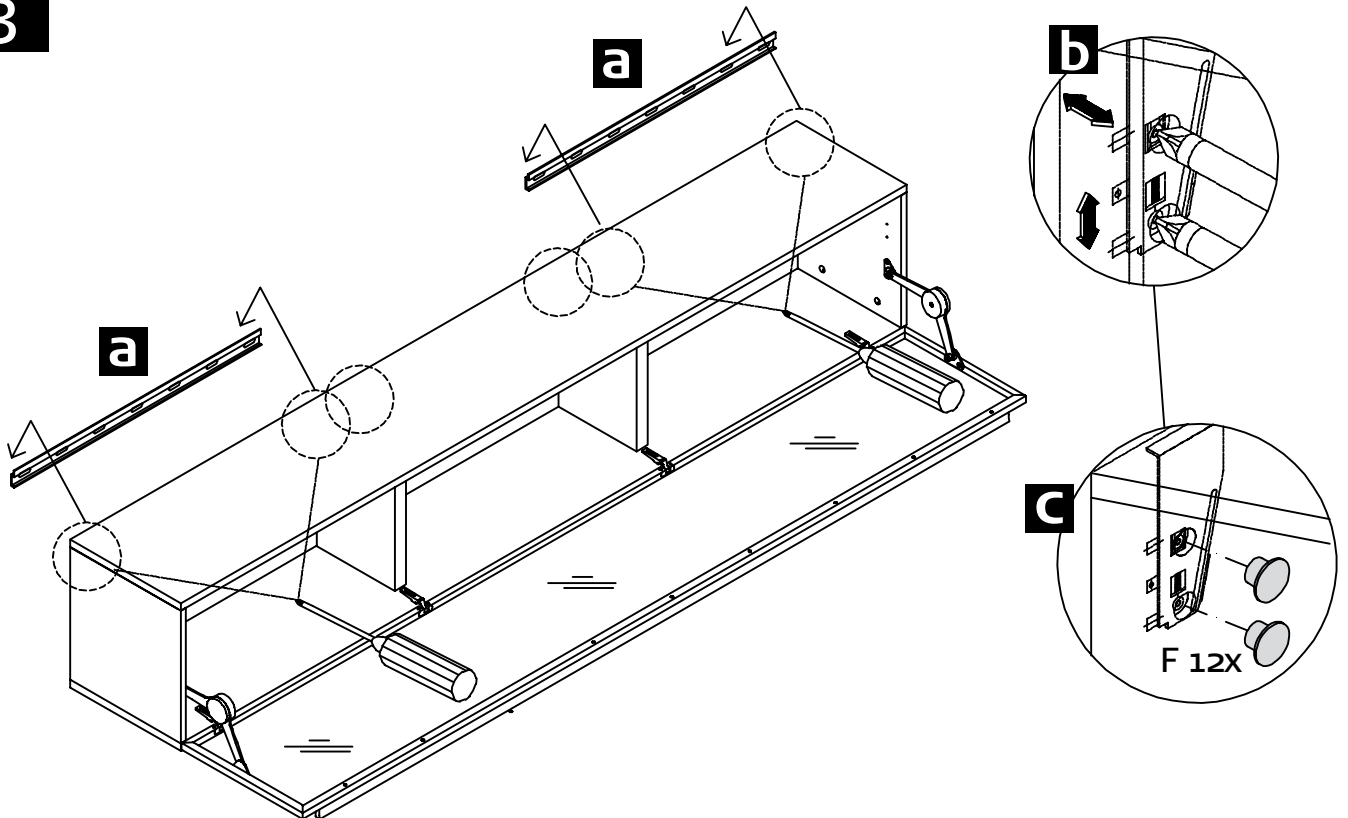

SERVICE

Stand: 10.2010

Mat.Nr. 1358320

hülsta-werke · Karl-Hüls-Straße 1 · 48703 Stadtlohn
 TEL.+49 2563 86-0 · FAX +49 2563 86-1417
 www.huelsta.com · info@huelsta.com